

8.6 DO135

8.6.1 Technical Data



Module ID	DO135
General Information	
Model Number	7DO135.70
Short Description	2003 digital output module, 4 FET outputs 12 to 24 VDC, 0.1 A, screw-in module, Order terminal block TB712 separately!
C-UL-US Listed	Yes
B&R ID Code	\$14
Slot	AF101 adapter module, CP interface
Static Characteristics	
Module Type	B&R 2003 screw-in module
Number of Outputs	4
Design	FET
Type	Push/Pull switch
Switching Voltage/Supply	
Minimum	11.4 VDC
Nominal	12 - 24 VDC
Maximum	30 VDC
Protection	Reverse polarity protection
Continuous Current per	
Output	Max. 0.1 A
Module	Max. 0.4 A
Maximum Switching Frequency	100 kHz
Residual Voltage	Max. 0.6 V at 0,1 A
Capacitive Load	Max. 20 nF An overcurrent warning is given when switching large capacitive loads
Power Consumption	Max. 0.2 W

Module ID	DO135
Protection Characteristics	
Protection Short circuit protection Overload protection	Yes Yes
Short Circuit Current	0.11 - 0.3A
Diagnosis Status for SW Evaluation Overvoltage Undervoltage Overcurrent Monitoring	Us >30 VDC, a voltage >35 VDC for t >5 ms will damage the outputs Us <10.5 VDC Functions with a duty cycle of at least 10 μ s
Dynamic Characteristics	
Switching Delay Typical Maximum	<2 μ s 2.4 μ s
Operating Characteristics	
Electrical Isolation Output - PCC Output - Output	No No
Cable Requirement	Shielded cable
Mechanical Properties	
Dimensions	B&R 2003 screw-in module

8.6.2 General Information

The DO135 is a 4 channel output module. The outputs are tristate when switched on. All outputs are activated as a group after the outputs are configured using configuration word 14.

8.6.3 Operating Modes

Operating modes can be set separately for each output. The following operating modes are available:

- Normal operation
- Pulse width modulation (PWM)
- TPU operation

Normal Operation

The outputs are switched on/off.

Pulse Width Modulation

Output are switched on/off periodically. Pulse width ratio, period duration and resolution can be set.

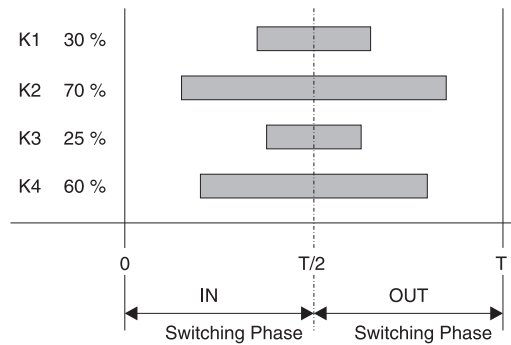

TPU Operation

In TPU operation, the outputs are controlled by the TPU. If e.g. the DO135 module is inserted in the first slot of the CP interface, the first output can be operated using the LTX function `LTXdo0()`.

8.6.4 Special Functions

- The supply voltage is tested over a valid range. ($10.5 \text{ VDC} < U_s < 30 \text{ VDC}$)
- The channels are equipped with readable power cut-off

8.6.5 Output Circuit Diagram

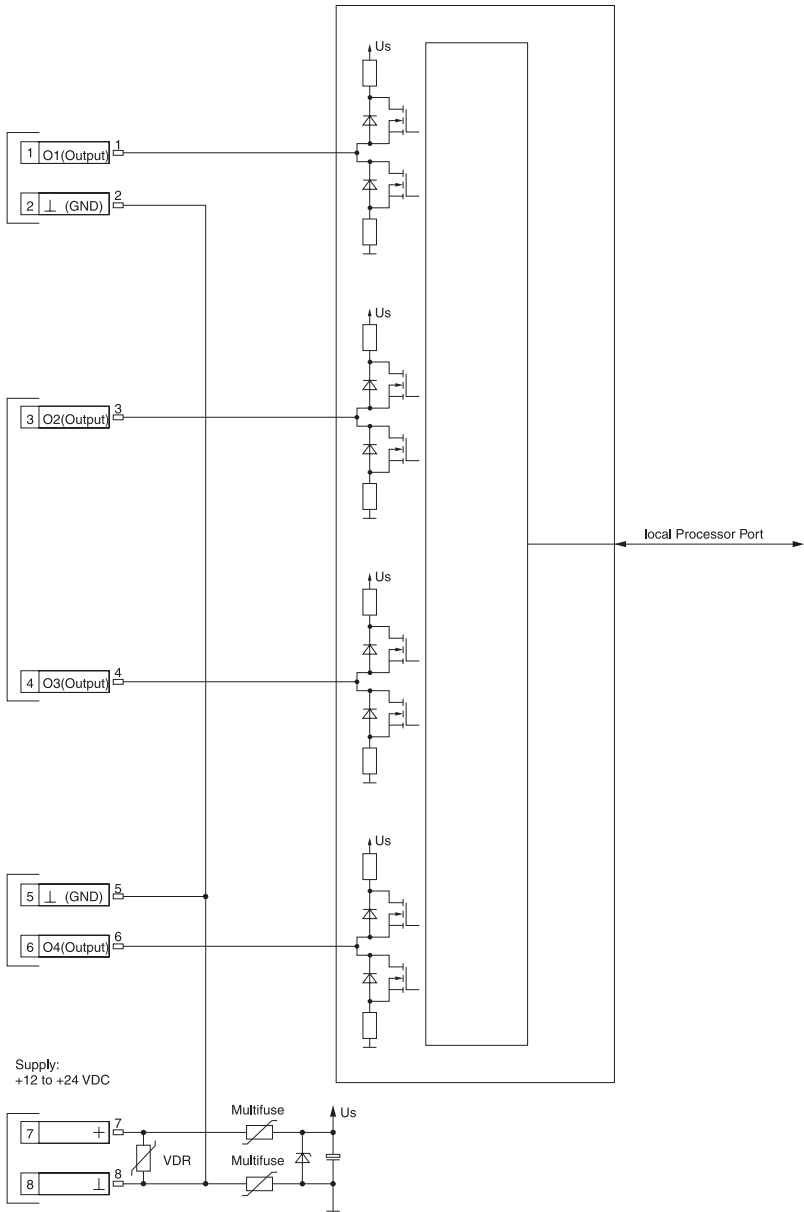

8.6.6 Connections

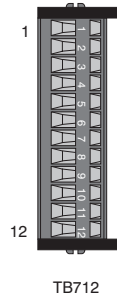

Pin	Assignment
1	Shield
2	Output 1
3	GND
4	Output 2
5	Shield
6	Shield
7	Output 3
8	GND
9	Output 4
10	Shield
11	+12 to +24 VDC
12	GND

8.6.7 Connection Example

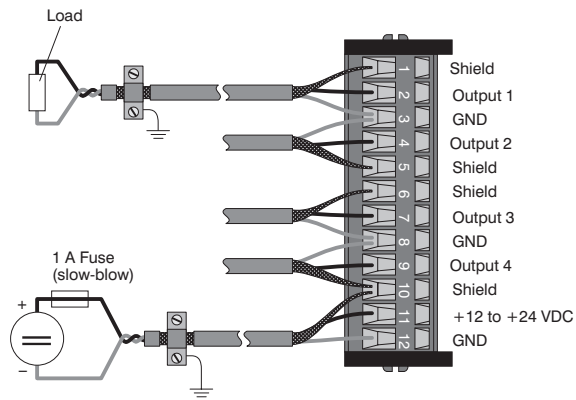

Supply:
 12 to 24 VDC
 Protect with 1 A slow-blow fuse!

8.6.8 Variable Declaration

The variable declaration is valid for the following controllers:

- 2003 PCC CPU
- Remote I/O Bus Controller
- CAN Bus Controller

The variable declaration is made in PG2000. The variable declaration is described in Chapter 4, "Module Addressing".

Automation Studio™ Support: See Automation Studio™ Help starting with V 1.40

Accessing screw-in modules is also explained in the sections "AF101" and "CPU".

Data access takes place using data and configuration words. The following table provides an overview of which data and configuration words are used for this module.

Data Access	VD Data Type	VD Module Type	VD Chan.	R	W	Description
Data word 0	WORD	Analog In	1	●		Switching phase counter for all channels (pulse width modulation)
	INT16	Analog Out	1		●	Output state or pulse width ratio for output 1
Data word 1	INT16	Analog Out	2		●	Output state or pulse width ratio for output 2
Data word 2	INT16	Analog Out	3		●	Output state or pulse width ratio for output 3
Data word 3	INT16	Analog Out	4		●	Output state or pulse width ratio for output 4
Configuration word 8	WORD	Transp. Out	16		●	Period time
Configuration word 9	WORD	Transp. Out	18		●	Factor for period time
Configuration word 12	WORD	Transp. In	24	●		Module status
Configuration word 14	WORD	Transp. In	28	●		Module type
	WORD	Transp. Out	28		●	Module configuration

8.6.9 Access Using CAN IDs

Access via CAN Identifiers is used if the slave is being controlled by a device from another manufacturer. Access via CAN Identifiers is described in an example in Chapter 4, "Module Addressing". The transfer modes are explained in Chapter 5, "CAN Bus Controller Functions".

Input Data (switching phase counter)

The switching phase counter can be transferred packed or unpacked in pulse width modulation operating mode.

CAN objects can only be sent back in packed mode.

CAN ID ¹⁾	Slot 1		Slot 2		Slot 3		Slot 4	
542	ScrM 1L	ScrM 1H	ScrM 2L	ScrM 2H	ScrM 3L	ScrM 3H	ScrM 4L	ScrM 4H
543	free							
544	free							
545	free							

¹⁾ CAN ID = 542 + (nd - 1) x 16 + (ma - 1) x 4

nd Node number of the CAN slave = 1

ma Module address of the AF101 = 1

Four CAN objects can be sent back in unpacked mode.

Slot	CAN ID ¹⁾	Word 1		Word 2	Word 3	Word 4
1	542	ScrM 1L	ScrM 1H	Not used (2 byte objects)		
2	543	ScrM 2L	ScrM 2H	Not used (2 byte objects)		
3	544	ScrM 3L	ScrM 3H	Not used (2 byte objects)		
4	545	ScrM 4L	ScrM 4H	Not used (2 byte objects)		

¹⁾ CAN ID = 542 + (nd - 1) x 16 + (ma - 1) x 4 + (sl - 1)

nd Node number of the CAN slave = 1

ma Module address of the AF101 = 1

sl Slot number of the screw-in module on the AF101 (1 - 4)

Output Data

It is not possible to pack output data with the DO135. Therefore one CAN object is transferred per screw-in module.

If an adapter module AF101 is equipped with a four DO135 modules, the CAN object has the following structure:

Slot	CAN ID ¹⁾	Word 1		Word 2		Word 3		Word 4	
1	1054	Chan. 1L	Chan. 1H	Chan. 2L	Chan. 2H	Chan. 3L	Chan. 3H	Chan. 4L	Chan. 4H
2	1055	Chan. 1L	Chan. 1H	Chan. 2L	Chan. 2H	Chan. 3L	Chan. 3H	Chan. 4L	Chan. 4H
3	1056	Chan. 1L	Chan. 1H	Chan. 2L	Chan. 2H	Chan. 3L	Chan. 3H	Chan. 4L	Chan. 4H
4	1057	Chan. 1L	Chan. 1H	Chan. 2L	Chan. 2H	Chan. 3L	Chan. 3H	Chan. 4L	Chan. 4H

¹⁾ CAN ID = 1054 + (nd - 1) x 16 + (ma - 1) x 4 + (sl - 1)

nd Node number of the CAN slave = 1

ma Module address of the AF101 = 1

sl Slot number of the screw-in module on the AF101 (1 - 4)



B&R 2000 users have to exchange the data so that the high data is first (Motorola format)!

For more information on ID allocation, see Chapter 5, "CAN Bus Controller Functions".

8.6.10 Description of Data and Configuration Words

Data Word 0 (read)

The switching phase of all channels in the pulse width modulation mode are counted with a 16-bit switching phase counter. The counter value can be read from data word 0.

It operates like a free running counter. This means that after reaching its highest value of 65535, the counter resets and begins again from 0.

The switching phase the output is currently in can be determined using the counter value.

Even Counter Value: Switch-on phase
 Odd Counter Value: Switch-off phase

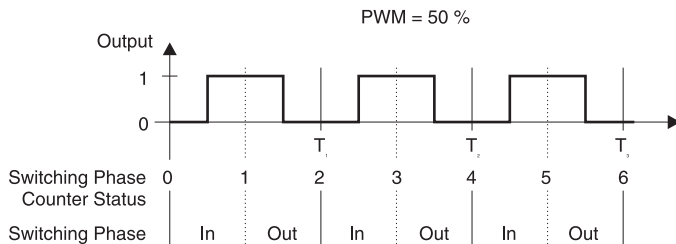

Switching Phase

In the switch-on phase (counter value is even), the output changes from OFF to ON. In the switch-off phase (counter value is odd), the output changes from ON to OFF.

The switching time is determined by the pulse width ratio.

Data words 0, 1, 2, 3 (write)

The output status and the pulse width ratio are defined with these data words according to the operating mode set.

Normal Operation

Bit 0 corresponds to the output state.

Output 1 = 0	Data word 0 = \$0000
Output 1 = 1	Data word 0 = \$0001
:	:
Output 4 = 0	Data word 3 = \$0000
Output 4 = 1	Data word 3 = \$0001

Pulse Width Modulation

This operating mode defines the pulse width ratio.

32767 (\$7FFF)	100 %
0 (\$0000)	0 %
Neg. Values	0 %

Example

Outputs 3 and 4 use operating mode pulse width modulation. The following pulse width ratios are defined:

Output 3	25 %	=>	25 % of 32767 = 8192 (\$2000) in data word 2
Output 4	75 %	=>	75 % of 32767 = 24575 (\$5FFF) in data word 3

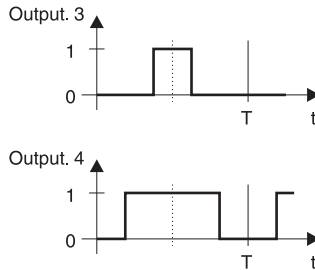

Configuration Word 8 (write)

The period time is defined with configuration word 8. The period time depends on the factor used (see configuration word 9).

The standard value for the factor is 4. This results in the definition of the period time in milliseconds (0 - 65535).

If the period time is set to 0, the outputs keep their value after the current period has passed (normally log 0, only log 1 with a pulse width ratio of 100%). The period counter is then cleared and remains 0.

If the period time is changed to a value between 1 and 65535, the period counter will be stopped, cleared and restarted with the new value after the current period of the period counter.

Period Time Unit

The period time unit is calculated with the following formula:

$$\text{Period time unit} = 250 \mu\text{s} * \text{factor}$$

Example

A factor of 4 gives the following period time unit:

$$\text{Period time unit} = 250 \mu\text{s} * 4 = 1 \text{ ms}$$

Configuration Word 9 (write)

The factor for the period time is defined with configuration word 9 (see configuration word 8).

The standard value for the factor is 4. This results in the definition of the period time in milliseconds.

The range of values lays between 1 and 256.

Larger values are limited to 256.



0 will be set to 256!

Pulse Width Modulation Resolution

Pulse width modulation resolution is calculated using the following formula:

$$\text{PWM resolution} = 125 \mu\text{s} * \text{factor}$$

The PWM resolution corresponds to the smallest pulse time.

Example

A typical module frequency range between 0.1Hz and 10 Hz results in the following resolution with a factor of 4:

Frequency	Period Time	Resolution	Smallest Pulse Width Ratio
0.1 Hz	10 s	20000 Ticks	0005 %
10 Hz	0.1 s	200 Ticks	0.5 %

To double the resolution with the same effective value, the factor can be divided in half.

Configuration word 12 (read)

Configuration word 12 contains the module status.

Bit	Description
8 - 15	x.... Not defined, masked out
7	0.... Supply voltage ≤30 V 1.... Supply voltage >30 V
6	0.... Supply voltage ≥10.5 V 1.... Supply voltage <10.5 V or current limitation has responded
5	0.... Half-period counter for pulse width modulation is counting 1.... Half-period counter for pulse width modulation is not counting
4	x.... Not defined, masked out
3	Switching level output 4
2	Switching level output 3
1	Switching level output 2
0	Switching level output 1

Configuration Word 14 (read)

The High Byte of configuration word 14 defines the module code.

Bit	Description
8 - 15	Module code = \$14
0 - 7	x....Not defined, masked out

Configuration Word 14 (write)

The module is configured using configuration word 14.

Channel is not active

All outputs are tristate when they are all set to operating mode "channel not active".

TPU Operation

The output state is defined with LTX functions (e.g. LTXdo0()) for outputs with this operating mode.

