

11.1 CM211

11.1.1 Order Data

Model No.	Short Description	Image
7CM211.7	2003 Combination Module, 8 inputs, 24 VDC, 4 ms, sink, 3 one channel or 2 two channel counters or 2 incremental encoders, 20 kHz, 8 transistor outputs, 24 VDC, 0.5 A, comparator function, short-circuit protection, 2 inputs, ± 10 V / 0-20 mA, 12 bit, 2 outputs, ± 10 V, 12 bit. Order TB718 terminal block separately.	
7TB718.9	Terminal block, 18 pin, screw clamps	
7TB718.91	Terminal block, 18 pin, cage clamps	
7TB718:90-02	Terminal block, 18 pin, 20 pcs., screw clamps	
7TB718:91-02	Terminal block, 18 pin, 20 pcs., cage clamps	
7TB736.9	2003 terminal block, 36 pin, screw clamps	
7TB736.91	2003 terminal block, 36 pin, cage clamps	
7TB754.9	2003 terminal block, 54 pin, screw clamps	
7TB754.91	2003 terminal block, 54 pin, cage clamps	
Terminal blocks are not included in the delivery.		

Table 18: CM211 order data

11.1.2 Technical Data

Product ID	CM211
General Information	
C-UL-US Listed	In preparation
B&R ID Code	§C3
Module Type	B&R 2003 I/O module
Amount ¹⁾ CP430, EX270, EX470, EX770 CP470, CP770, CP474, CP476, CP774 EX477, EX777	2 4 4
External Voltage Monitoring	Yes (LED: OK), supply voltage >18 V
Electrical Isolation Analog - PLC Digital - PLC Digital - Analog	No No No
Power Consumption	Max. 1.5 W

Table 19: CM211 technical data

Product ID	CM211	
Analog Inputs		
Input Type	Asymmetric	
Number of Inputs	2	
Input Signal - Nominal	$\pm 10\text{ V} / 0 - 20\text{ mA}$ can be set for each channel with switch	
Maximum Continuous Overload (without damage)	$\pm 15\text{ V} / \pm 50\text{ mA}$	
Digital Converter Resolution	12 bit	
Data Format Delivered to the Application Program	16 bit 2s complement	
Value Range		
Voltage		
+10 V	\$7FFF	
0 V	\$0000	
-10 V	\$8001	
Current		
20 mA	\$7FFF	
0 mA	\$0000	
Measurement Range Monitoring		
Open Inputs	\$7FFF	
Range Exceeded (neg.)		
Voltage	\$8001	
Current	\$0000	
Range Exceeded (pos.)	\$7FFF	
General Error	\$8000	
Conversion Method	Successive approximation	
Conversion Time	<4 ms for both channels, the channels are converted cyclically	
Input Impedance in Signal Range for voltage input	$\geq 1\text{ M}\Omega$	
input impedance in signal range for current input (load)	95 - 200 Ω	
Measurement Precision at 25 °C		
Offset	Voltage $\pm 2.62\text{ mV}$	Current $\pm 5.29\text{ }\mu\text{A}$
Gain	$\pm 0.2\% ^{2)}$	$\pm 0.2\% ^{2)}$
Offset Drift	$\pm 2\text{ mV}/^{\circ}\text{C}$	$\pm 5.9\text{ }\mu\text{A}/^{\circ}\text{C}$
Gain Drift	$\pm 65\text{ ppm}/^{\circ}\text{C} ^{3)}$	$\pm 75\text{ ppm}/^{\circ}\text{C} ^{3)}$
LSB Value (12 Bit)	$\pm 2.53\text{ mV} \pm 0.09\text{ mV}$	$\pm 5.09\text{ }\mu\text{A} \pm 0.2\text{ }\mu\text{A}$
Non-Linearity	$\pm 2\text{ LSB}$	
Input Filter	Cut-off Frequency 500 Hz	
Analog Outputs		
Number of Outputs	2	
Output Signal	$\pm 10\text{ V}$	
Load	Max. $\pm 10\text{ mA}$	
Digital Converter Resolution	12 bit	
Data Format in Application Program	16 bit 2s complement	

Table 19: CM211 technical data (cont.)

Product ID	CM211
Value Range +10 V 0 V -10 V	\$7FFF \$0000 \$8001
Conversion Time	<4 ms for both channels
Load Impedance	≥1 kΩ
Measurement Precision at 25 °C Offset Gain	±5.14 mV ±0.2 % ²⁾
Offset Drift	±1.2 mV/°C
Gain Drift	±40 ppm / °C ³⁾
LSB Value (12 Bit)	±5.01 mV ±0.13 mV
Non-Linearity	±3.5 LSB
Short Circuit Protection	Yes
Digital Inputs	
Number of Inputs	8
Type of Inputs	3 x event counters, 3 x period measurement, 3 x gate measurement, 2 x incremental encoder ABR (+24 V), 1 x comparator
Input Voltage Minimum Nominal Maximum	18 VDC 24 VDC 30 VDC
Input Current at Nominal Voltage	Approx. 4 mA
Wiring	Sink
Switching Threshold LOW Range HIGH Range	< 5 V > 15 V
Delay 0 to 1 with SW Filter without SW Filter	<4 ms (default) < 0.01 ms
Delay 1 to 0 with SW Filter without SW Filter	<4 ms (default) < 0.01 ms
Status Display	8 Green LEDs

Table 19: CM211 technical data (cont.)

Product ID	CM211
Incremental Encoder Operation Signal Form Evaluation Input Frequency Count Frequency Counter Size Input 1 Input 2 Input 3 Input 4 Input 5 Input 6 Input 7 Input 8	Square wave pulse 4-fold, cyclic counter 20 kHz 80 kHz 32 bit Reference enable switch 1 Channel A1 Channel B1 Channel R1 Channel A2 Channel B2 Channel R2 Reference enable switch 2
Event Counter Operation Signal Form Evaluation Input Frequency Count Frequency Counter Size Input 2 Input 3 Input 5	Square wave pulse Each edge, cyclic counter 20 kHz 40 kHz 16 bit Counter 1 Counter 2 Counter 3
Period measurement Signal Form Evaluation Input Frequency Internal Counter Frequency External Counter Frequency Counter Size Input 3 Input 4 Input 7 Input 2 Input 5	Square wave pulse Positive edge - Positive edge 20 kHz 16 MHz, 4 MHz, 1 MHz, 250 kHz Max. 20 kHz 16 bit Period channel 1 Period channel 2 Period channel 3 External counter frequency for channels 1 and 2 External counter frequency for channel 3
Gate measurement Signal Form Evaluation Input Frequency Internal Counter Frequency External Counter Frequency Counter Size Gate Pause Input 3 Input 4 Input 7 Input 2 Input 5	Square wave pulse Positive edge - Negative edge 10 kHz 16 MHz, 4 MHz, 1 MHz, 250 kHz Max. 20 kHz 16 bit 50 µs Gate channel 1 Gate channel 2 Gate channel 3 External counter frequency for channels 1 and 2 External counter frequency for channel 3

Table 19: CM211 technical data (cont.)

Product ID	CM211
Comparator	
Comparator Output	Output 1
Reaction time	<500 μ s
Evaluation	
Incremental Encoder Operation	Actual value comparison of the counter status of incremental encoder 1
Event Counter Operation	Comparison of the counter status of counter 2 (window comparator)
Comparator Output	Output 2
Reaction time	< 2 ms
Evaluation	
Incremental Encoder Operation	Actual value comparison of the counter status of incremental encoder 2
Event Counter Operation	Comparison of the counter status of counter 3 (window comparator)
Electrical Isolation Input - Input	No
Digital Outputs	
Number and Type of Outputs	8 transistor outputs
Rated Current	Max. 0.5 A
Total Output Current	Max. 4 A
Rated Voltage	24 VDC
Switching Voltage Range	18 - 30 VDC
Leakage Current (0 signal)	12 μ A
Wiring	Source
Short Circuit Protection	Yes
Overload Protection	Yes
Braking Voltage when Switching Off Inductive Loads	47 V
Delay 0 to 1	< 1.5 ms
Delay 1 to 0	< 1.5 ms
Status Display	8 orange LEDs
Electrical Isolation Output - Output	No
Mechanical Characteristics	
Dimensions	B&R 2003 single width

Table 19: CM211 technical data (cont.)

- 1) Two logical module slots are required by the module.
- 2) Referring to the maximum positive limit.
- 3) Referring to the current measurement value.

11.1.3 Status LEDs

LED	Description
OK	This orange LED is lit when the external supply voltage for the outputs is within the defined range (> 18 VDC).
LED 1 - 8, green	Logical status of the respective digital input.
LED 1 - 8, orange	Control status of the respective digital output.

Table 20: CM211 status LEDs

11.1.4 Input Circuit Diagram

Analog Inputs

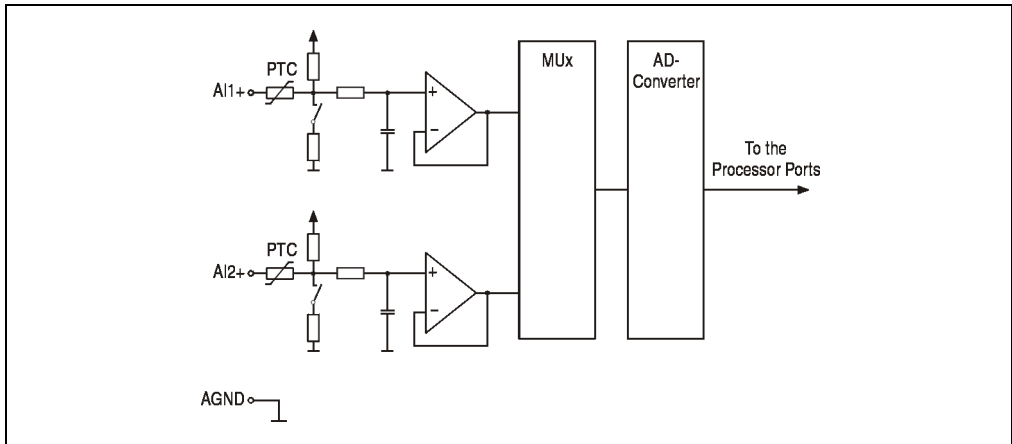

Figure 42: CM211 input circuit diagram for analog inputs

Digital Inputs

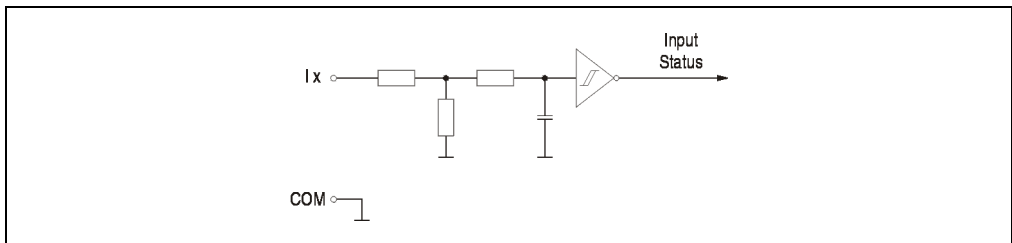

Figure 43: CM211 input circuit diagram for digital inputs

11.1.5 Output Circuit Diagram

Analog Outputs

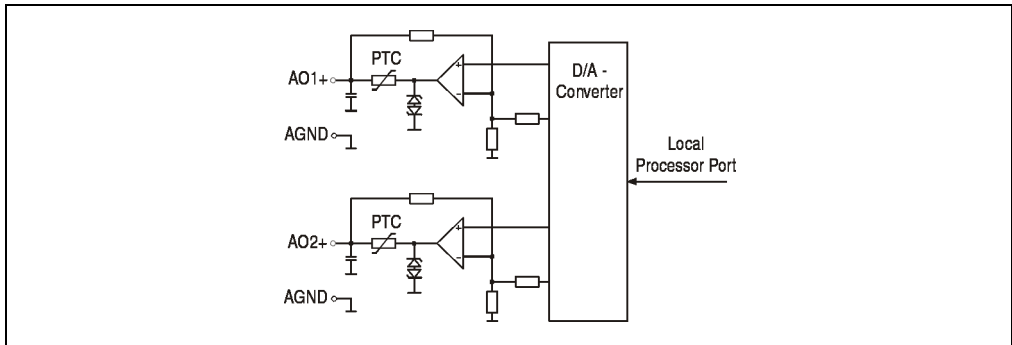

Figure 44: CM211 output circuit diagram for analog outputs

Digital Outputs

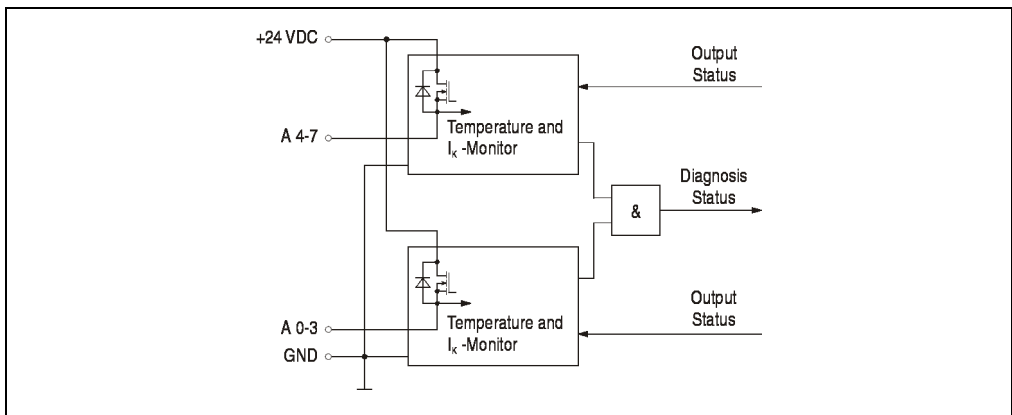

Figure 45: CM211 output circuit diagram for digital outputs

11.1.6 Monitoring the Supply Voltage

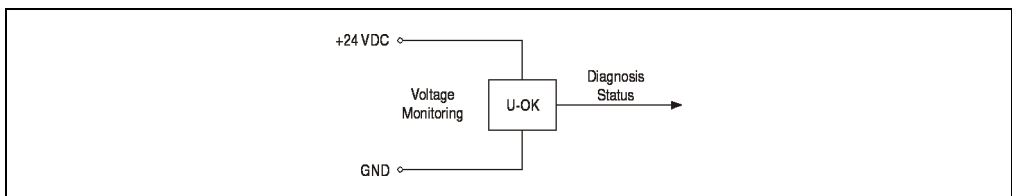

Figure 46: CM211 monitoring the supply voltage

11.1.7 Module Design

General Information

The design of the combination module CM211 corresponds to an adapter module AF101 with four screw-in modules installed and a digital mixed module.

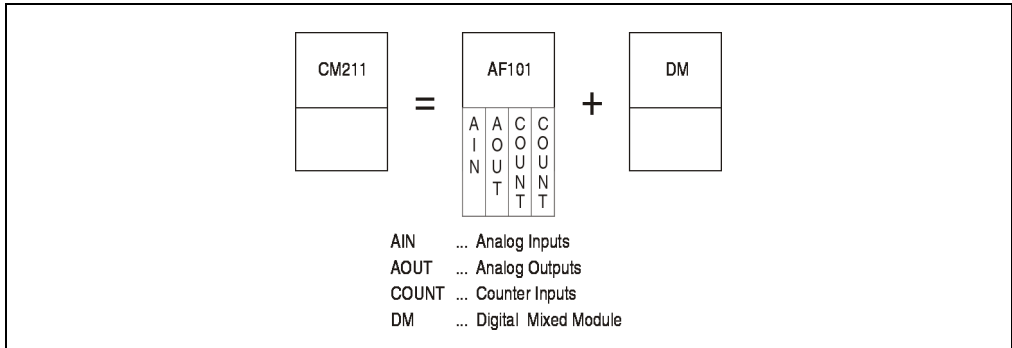

Figure 47: CM211 module design

Module Addresses

Because of this special module design, the combination module CM211 requires two module addresses.

A CPU, a combination module CM211 and a digital input module DI435 are used in the example shown below. The module address assignments are to be made as shown in the diagram.

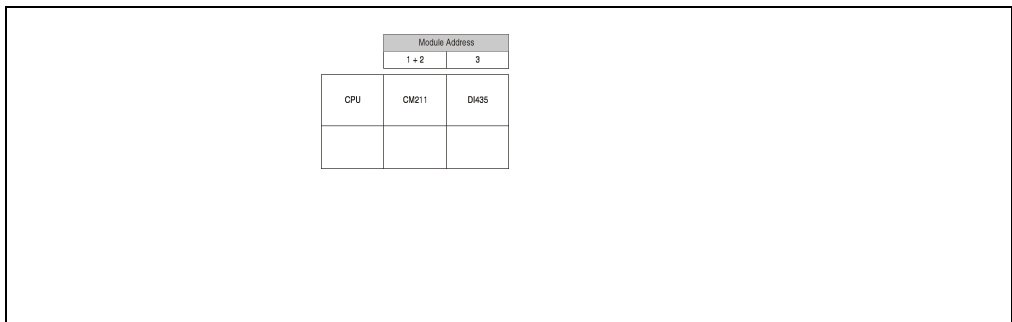

Figure 48: CM211 module addresses

Variable Declaration

To avoid conflicts in the register, the settings listed below must be used in the variable declaration for the module address and for the slot. In this case, the module is accessed with module addresses 1 and 2.

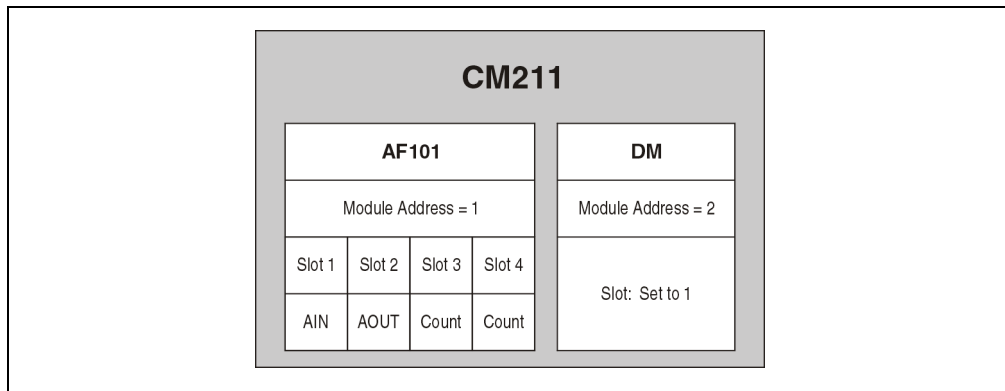

Figure 49: CM211 variable declaration

11.1.8 Configuration Options for the Counter

Counter Inputs

Section "Module Design" explains that the combination module corresponds to an adapter module AF101 with four screw-in modules and a digital mixed module. Two of the four screw-in modules are used for counter inputs.

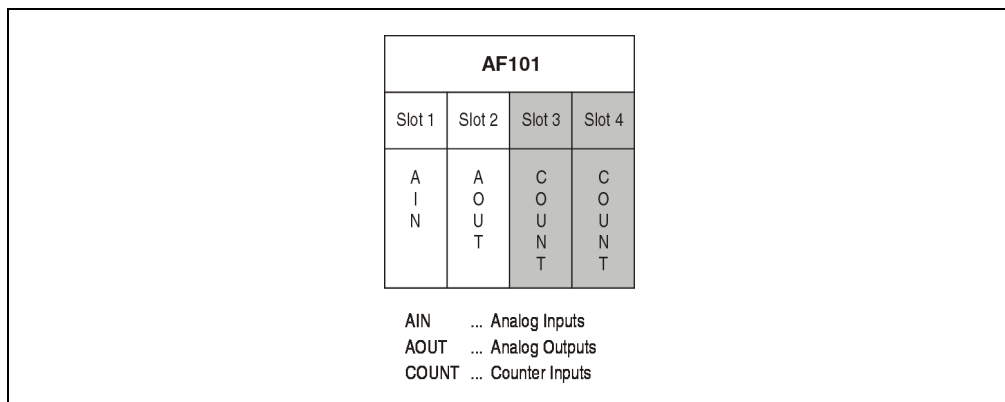

Figure 50: CM211 configuration options counter inputs

Counter Inputs in Slot 3

The counter inputs on the screw-in module installed in slot 3 can be configured using software. The desired function is set by defining bits 12 and 13 in configuration word 14. One of three functions can be selected.

Function	Bit 12	Bit 13
1 x incremental encoder	0	0
2 x event counter	1	0
2 x gate/period measurement	1	1

Table 21: CM211 counter inputs in slot 3

Counter Inputs in Slot 4

The counter inputs on the screw-in module installed in slot 4 can be configured using software. The desired function is set by defining bits 12 and 13 in configuration word 14. One of three functions can be selected.

Function	Bit 12	Bit 13
1 x incremental encoder	0	0
1 x event counter	1	0
1 x gate/period measurement	1	1

Table 22: CM211 counter inputs in slot 4

11.1.9 Timing

The following three factors must be taken into consideration for timing when a B&R 2003 CPU is used as controller:

- Internal Bus Cycle
- I/O-AF Cycle
- I/O CPU Load

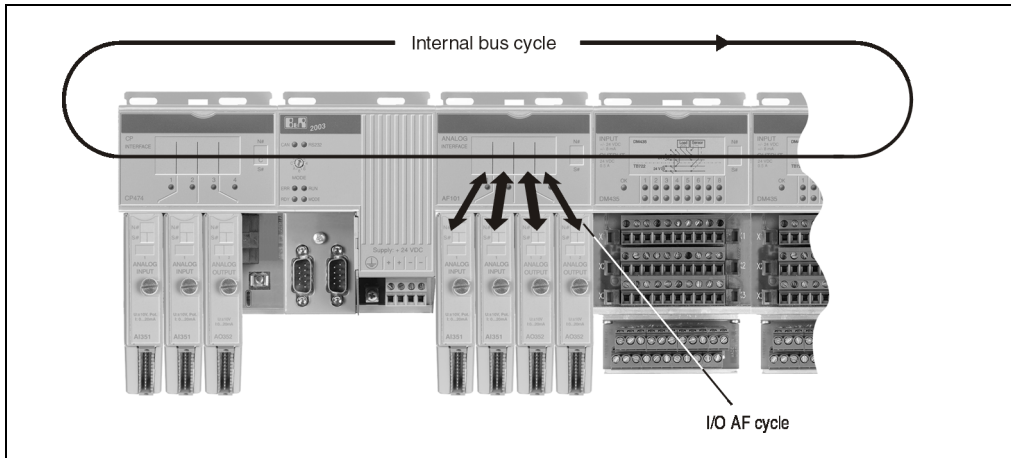

Figure 51: CM211 response time

Internal Bus Cycle

All combination modules, AF modules and digital I/O modules are processed during this time. The internal bus cycle for a CM211 is calculated as follows:

There is no AF101 adapter module on the bus

$$t_{\text{int_cycle}} = n * 36 \mu\text{s} * 12 + 12 * 120 \mu\text{s} + 1200 \mu\text{s} = 3072 \mu\text{s} \quad (n = 1)$$

- n Number of CM211 modules
- 36 μs Time for a combination module CM211
- 12 Number of data words for a CM211
- 120 μs Combination module CM211 busy
- 1200 μs Offset

There is an AF101 adapter module on the bus or a CPx74 is used as CPU

$$t_{\text{int_cycle}} = n * 36 \mu\text{s} * 12 + 12 * 200 \mu\text{s} + 1200 \mu\text{s} = 4032 \mu\text{s} \quad (n = 1)$$

nNumber of CM211 modules
 36 μs Time for a combination module CM211
 12Number of data words for a CM211
 200 μs AF101 or CPx74 busy
 1200 μs Offset

I/O AF cycle for digital data points

During this time, all digital data points on the combination module CM211 are updated or read internally.

$$t_{\text{dig_IO_AF}} \leq 1 \text{ ms}$$

I/O AF cycle for analog data points

During this time, all analog data points on the combination module CM211 are updated or read internally.

Counter values $t_{\text{an_IO_AF}} \leq 2 \text{ ms}$
 Analog I/O values $t_{\text{an_IO_AF}} \leq 4 \text{ ms}$

I/O CPU Load

This time determines how long the CPU requires to process the I/O data passed on by the combination module CM211. The CPU is loaded considerably by the analog I/O data.

A CP430 or CPx70 is used as CPU

$t_{\text{IO_CPU}} = 12 * 100 \mu\text{s} = 1200 \mu\text{s}$
 12Number of data words for a CM211
 100 μs Analog data point on CP430 or CPx70

A CPx74 is used as CPU

$t_{\text{IO_CPU}} = 12 * 70 \mu\text{s} = 840 \mu\text{s}$
 12Number of data words for a CM211
 70 μs Analog data point on CPx74

A CP476 is used as CPU

$$t_{IO_CPU} = 12 * 50 \mu s = 600 \mu s$$

12Number of data words for a CM211

50 μs Analog data point on CP476

Task Class

Fastest Task Class Recommended: 6 ms

11.1.10 Legend Sheets

A legend sheet can be slid into the front of the module from above. The module circuit is shown on the back. The inputs/outputs can be labelled on the front.

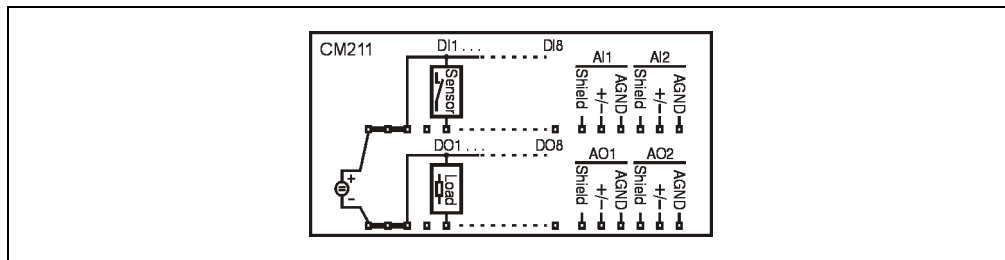

Figure 52: CM211 legend sheet

11.1.11 Connections

Ground Screw

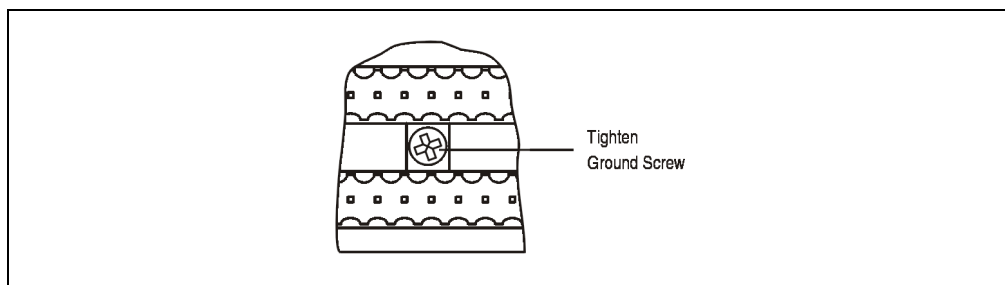

Figure 53: CM211 ground screw

Terminal Block X1

Terminal Block X1 Pin Assignments	
Pin	Assignment
1	+24 VDC
2	+24 VDC
3	+24 VDC
4	NC
5	Digital input DI1
6	Digital input DI2
7	Digital input DI3
8	Digital input DI4
9	Digital input DI5
10	Digital input DI6
11	Digital input DI7
12	Digital input DI8
13	Shield
14	Analog input AI1 +
15	Analog input 1 GND (AGND)
16	Shield
17	Analog input AI2 +
18	Analog input 2 GND (AGND)

The diagram shows a top-down view of a terminal block with 18 pins. The pins are numbered 1 through 18 from left to right. The block is labeled 'X1' above it and 'TB718' below it.

Table 23: CM211 pin assignment for terminal block X1

Terminal Block X2

Terminal Block X2 Pin Assignments	
Pin	Assignment
1	GND
2	GND
3	GND
4	NC
5	Digital output DO1
6	Digital output DO2
7	Digital output DO3
8	Digital output DO4
9	Digital output DO5
10	Digital output DO6
11	Digital output DO7
12	Digital output DO8
13	Shield
14	Analog output AO1 +
15	Analog output 1 GND (AGND)
16	Shield
17	Analog output AO2 +
18	Analog output 2 GND (AGND)

The diagram shows a top-down view of a terminal block with 18 pins. The pins are numbered 1 through 18 from left to right. Above the block is the label 'X2' and below it is 'TB718'. The pins are arranged in a single row with a central gap between pins 12 and 13.

Table 24: CM211 pin assignment for terminal block X2

11.1.12 Analog Inputs Connection Example

The combination module CM211 has two analog inputs which may be used as either voltage or current input. Mixed operation is also possible.

Mode Switch

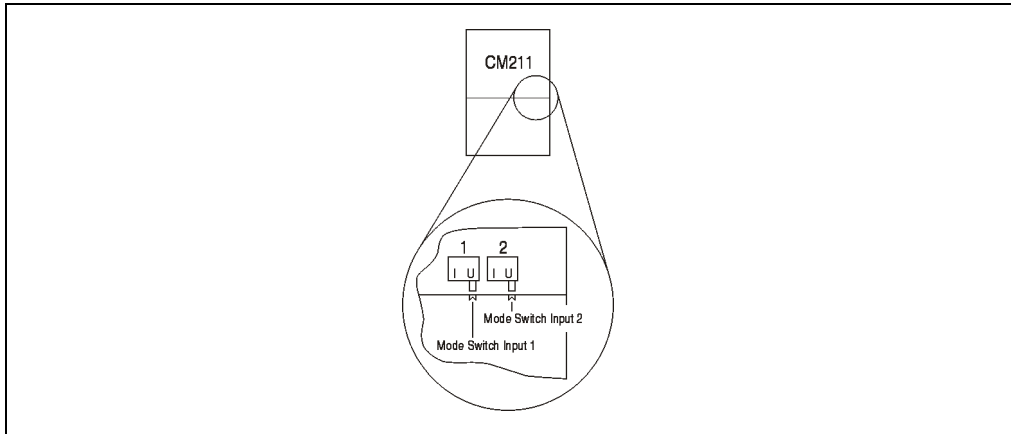

Figure 54: CM211 mode switch

An input can be used as either voltage or current input. The selection is made with the respective mode switch on the bottom of the housing. Place the switch in the respective position for the desired signal:

U..... Voltage Input

I..... Current Input

Module Wiring

In the following example, input 1 is used as voltage input.

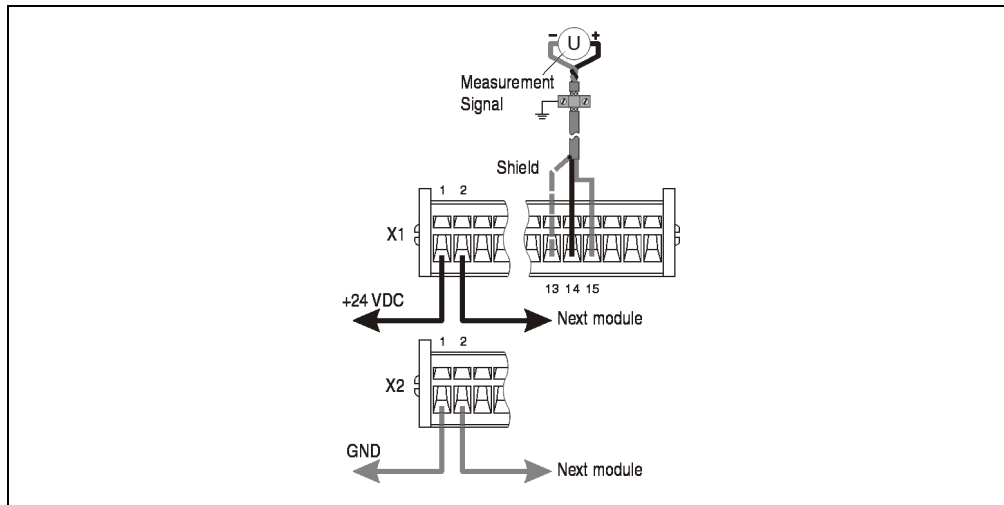

Figure 55: CM211 analog input connection example

11.1.13 Analog Output Connection Example

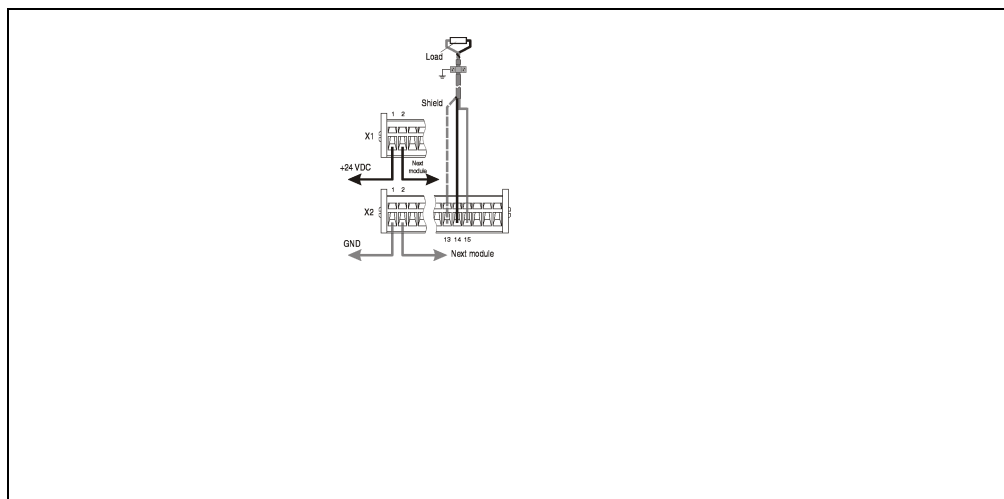

Figure 56: CM211 analog output connection example

11.1.14 Incremental Encoder Operation

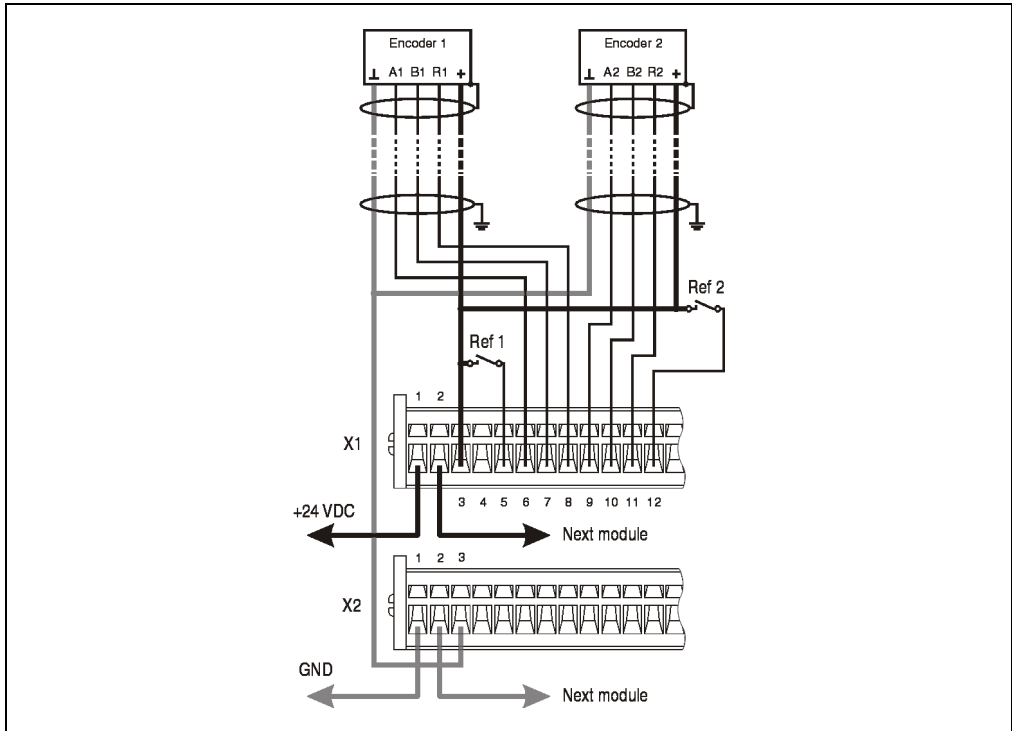

Figure 57: CM211 incremental encoder operation connection example

11.1.15 Event Counter Operation Connection Example

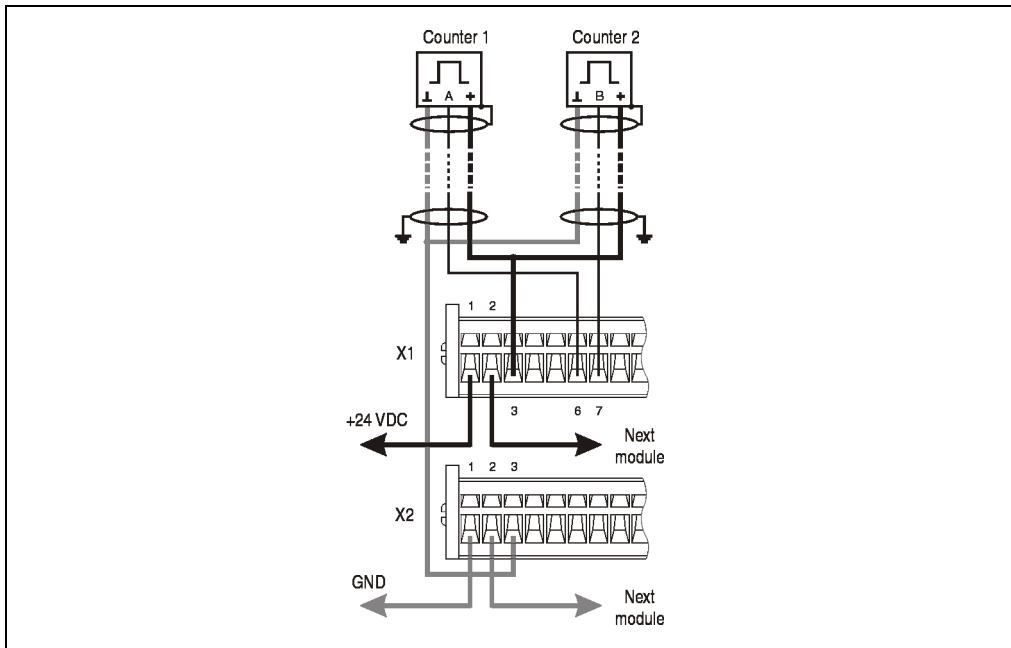

Figure 58: CM211 event counter operation connection example

11.1.16 Period Measurement Connection Example

The period can be measured from a signal connected to input 3, 4 or 7. The resolution is 16 bit. The frequency of the signal to be measured can be a maximum of 20 kHz. An internal or external counter frequency can be selected for the measurement.

- Internal counter frequency (16 MHz, 4 MHz, 1 MHz or 250 kHz)
- External counter frequency (max. 20 kHz)

The external counter frequency is connected to input 2 (for inputs 3 and 4) and 5 (for input 7).

Period Measurement Principle

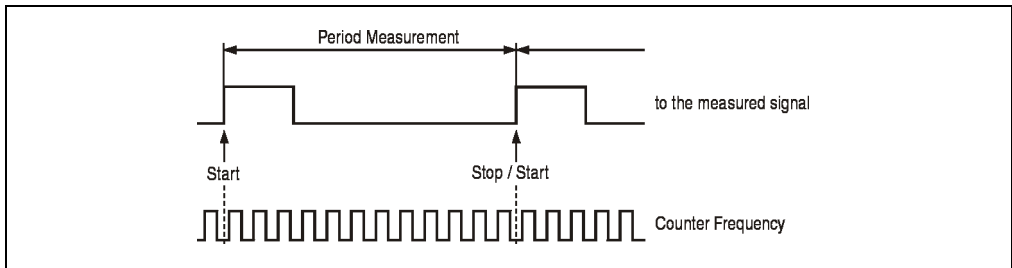

Figure 59: CM211 period measurement principle

Pulse counting is started by a rising edge on the input and stopped by the next rising edge. The count is placed in a temporary register. The counter is started again by the same rising edge.

During period measurement, the count stored last (the period) can be read by the active application program. The value in the temporary register is only updated after at the end of the active measurement. If a counter overflow occurs (broken line or incorrect counter frequency), the value is limited to \$7FFF.

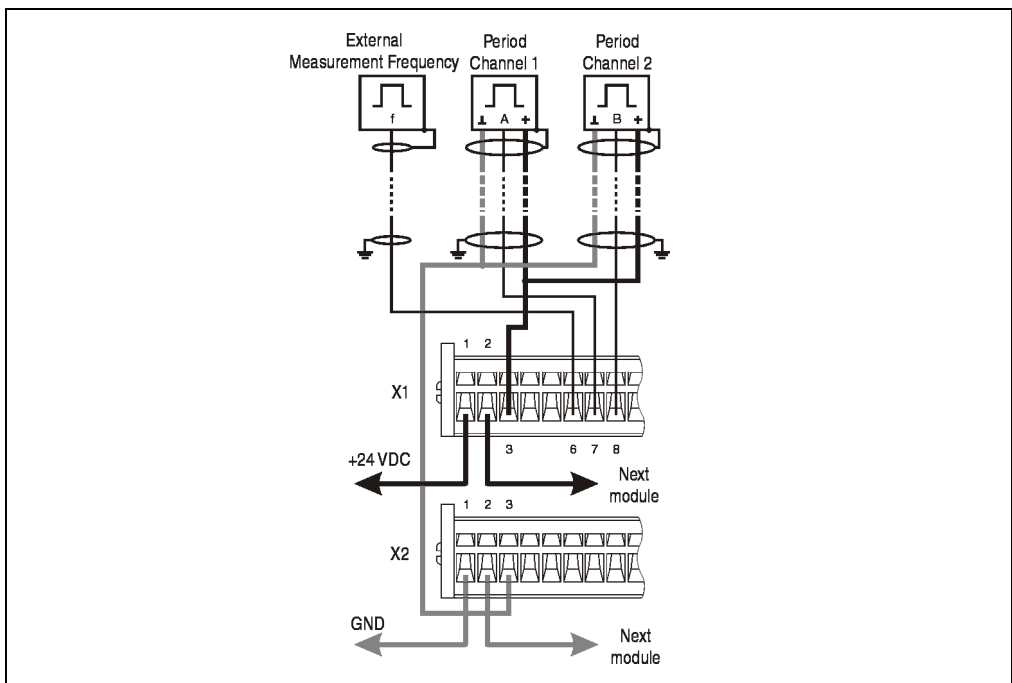

Figure 60: CM211 period measurement connection example

11.1.17 Gate Measurement Connection Example

A signal connected to input 3, 4 or 7 can be evaluated using gate measurement. The resolution is 16 bit. The frequency of the signal to be measured can be a maximum of 10 kHz. The signal to be measured is also called the gate frequency. The pause between two gate measurements must be larger than 50 μs .

An internal or external counter frequency can be selected for the measurement.

- Internal counter frequency (16 MHz, 4 MHz, 1 MHz or 250 kHz)
- External counter frequency (max. 20 kHz)

The external counter frequency is connected to input 2 (for inputs 3 and 4) and 5 (for input 7).

Gate Measurement Principle

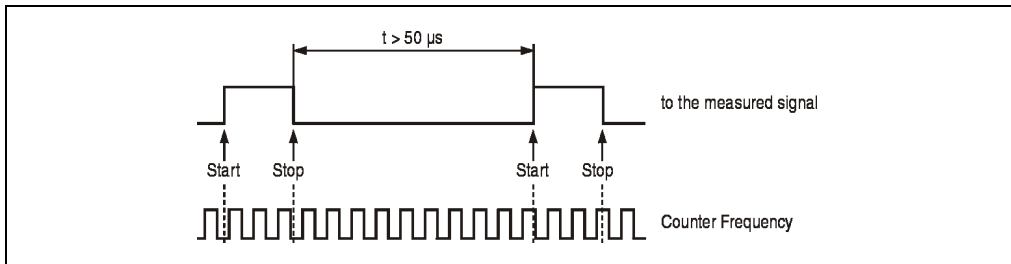

Figure 61: CM211 gate measurement principle

Pulse counting is started by a rising edge on the gate and stopped by a falling edge. The count is placed in a temporary register when the falling edge occurs. The counter is started again by the next rising edge.

During gate measurement, the count stored last (the gate) can be read by the active application program. The value in the temporary register is only updated after at the end of the active measurement (falling edge). If a counter overflow occurs (incorrect counter frequency), the value is limited to \$7FFF.

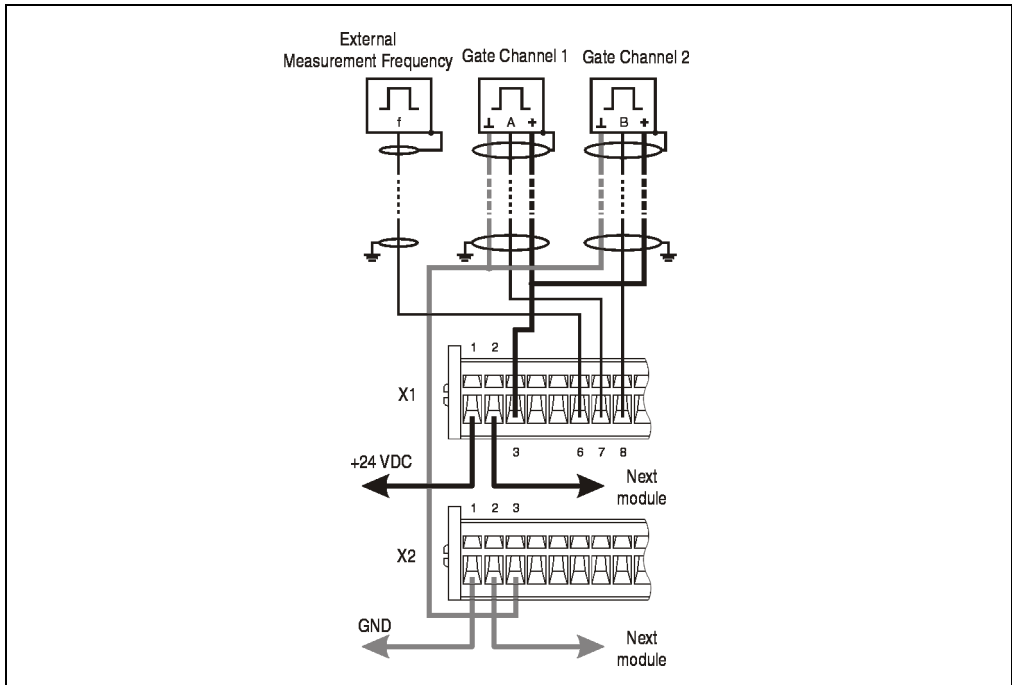

Figure 62: CM211 gate measurement connection example

11.1.18 Digital Output Connection Example

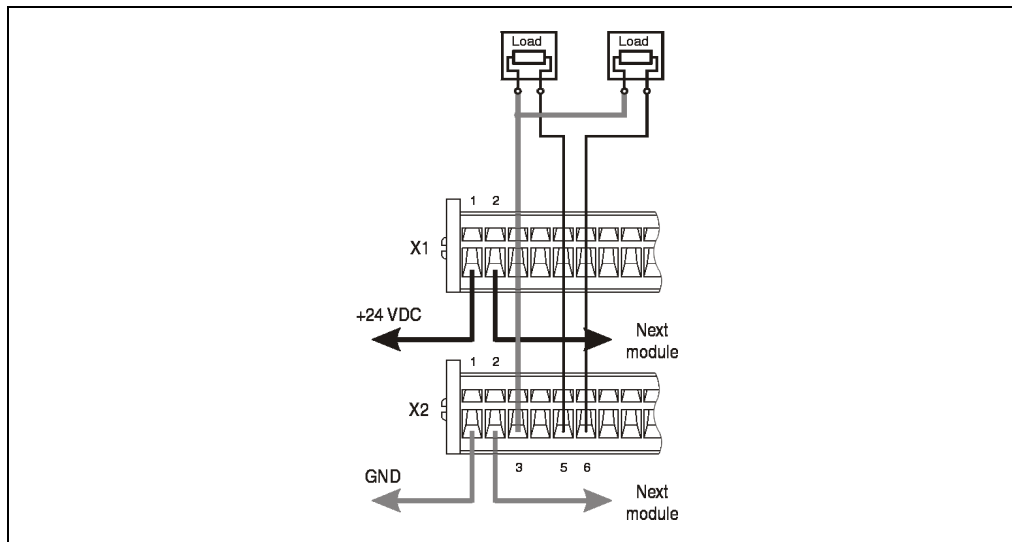

Figure 63: Digital Output Connection Example

11.1.19 Variable Declaration for the Analog Inputs

The variable declaration is valid for the following controllers:

- CPU for the PLC 2003
- Remote I/O Bus Controller
- CAN Bus Controller

The variable declaration is made in PG2000. The variable declaration is provided in Chapter 4 "Module Addressing".

Automation Studio™ Support: See Automation Studio™ Help starting with V 1.40

Accessing screw-in modules is also explained in the sections "AF101" and "CPU". Data access takes place using data and configuration words. The following table provides an overview of which data and configuration words are used for the analog inputs.

Data Access	VD Data Type	VD Module Type	VD Chan.	R	W	Description
Data word 0	INT16	Analog In	1	●		Analog input value channel 1
Data word 1	INT16	Analog In	2	●		Analog input value channel 2
Configuration word 12	WORD	Transp. In	24	●		Module status
Configuration word 14	WORD	Transp. In	28	●		Module Type

Table 25: CM211 variable declaration for the analog inputs

Access using CAN Identifier

Access via CAN Identifiers is used if the slave is being controlled by a device from another manufacturer. Access via CAN Identifiers is described in an example in Chapter 4, "Module Addressing". The transfer modes are explained in Chapter 5, "CAN Bus Controller Functions" .

In the example below, the combination module CM211 is accessed with module addresses 1 and 2. Analog input data cannot be packed. Only the first object from this group of four will be created and sent.

Slot	CAN-ID ¹⁾	Word 1		Word 2		Word 3	Word 4
1	542	Channel 1L	Channel 1H	Channel 2L	Channel 2H	Not used	
2	543	Not used					
3	544	Not used					
4	545	Not used					

Table 26: CM211 access using CAN identifier, analog inputs

1) CAN-ID = 542 + (nd - 1) x 16 + (ma - 1) x 4 + (sl - 1)
 nd.....Node number for the CAN slaves = 1
 ma.....Module address = 1
 sl.....Slot number = 1



B&R 2000 users have to exchange the data so that the high data is first (Motorola format)

For more information on ID allocation, see Chapter 5 , "CAN Bus Controller Functions".

Description of Data and Configuration Words

Data Words 0 and 1 (read)

16 bit standardized values representing either voltage or current.

Configuration Word 12 (read)

Configuration word 12 contains the module status.

		Bit	Description
		12 - 15	x ... Not defined, masked out
		11	0 ... Converter values ready 1 ... Converter values not yet ready
		6 - 10	x ... Not defined, masked out
		5	0 ... Channel 2: Current measurement 1 ... Channel 2: Voltage measurement
		4	0 ... Channel 1: Current measurement 1 ... Channel 1: Voltage measurement
		2 - 3	x ... Not defined, masked out
		1	0 ... Channel 2: No error 1 ... Channel 2: Error present
		0	0 ... Channel 1: No error 1 ... Channel 1: Error present

15 8 7 0

Configuration Word 14 (read)

The High Byte of configuration word 14 defines the module code.

		Bit	Description
		8 - 15	Module code = \$40
		0 - 7	x ...Not defined, masked out

15 8 7 0

11.1.20 Variable Declaration for Analog Outputs

The variable declaration is valid for the following controllers:

- CPU for the PLC 2003
- Remote I/O Bus Controller
- CAN Bus Controller

The variable declaration is made in PG2000. The variable declaration is provided in Chapter 4 "Module Addressing".

Automation Studio™ Support: See Automation Studio™ Help starting with V 1.40

Accessing screw-in modules is also explained in the sections "AF101" and "CPU".

Data access takes place using data and configuration words. The following table provides an overview of which data and configuration words are used for the analog outputs.

Data Access	VD Data Type	VD Module Type	VD Chan.	R	W	Description
Data word 0	INT16	Analog Out	1		●	Analog output value channel 1
Data word 1	INT16	Analog Out	2		●	Analog output value channel 2
Configuration word 14	WORD	Transp. In	28	●		Module Type

Table 27: CM211 variable declaration for analog outputs

Access using CAN Identifier

Access via CAN Identifiers is used if the slave is being controlled by a device from another manufacturer. Access via CAN Identifiers is described in an example in Chapter 4, "Module Addressing". The transfer modes are explained in Chapter 5, "CAN Bus Controller Functions" .

In the example below, the combination module CM211 is accessed with module addresses 1 and 2. Analog output data cannot be packed. Only the second object from this group of four will be created.

Slot	CAN-ID ¹⁾	Word 1		Word 2		Word 3	Word 4
1	1054	Not used					
2	1055	Channel 1L	Channel 1H	Channel 2L	Channel 2H	Not used	
3	1056	Not used					
4	1057	Not used					

Table 28: CM211 access using CAN identifier, analog outputs

- 1) CAN-ID = 1054 + (nd - 1) x 16 + (ma - 1) x 4 + (sl - 1)
- nd.....Node number for the CAN slaves = 1
- ma.....Module address = 1
- sl.....Slot number = 2



B&R 2000 users have to exchange the data so that the high data is first (Motorola format)

For more information on ID allocation, see Chapter 5 , "CAN Bus Controller Functions".

Description of Data and Configuration Words

Data Words 0 and 1 (write)

The 16 bit standardized values for voltage are written to the module output channel.

Configuration Word 14 (read)

The High Byte of configuration word 14 defines the module code.

		Bit	Description															
		8 - 15	Module code = \$40															
		0 - 7	x ...Not defined, masked out															
0	1	0	0	0	0	0	0	0	x	x	x	x	x	x	x	x	x	x
15									8	7								0

11.1.21 Variable Declaration for Incremental Encoder Operation

The variable declaration is valid for the following controllers:

- CPU for the PLC 2003
- Remote I/O Bus Controller
- CAN Bus Controller

The variable declaration is made in PG2000. The variable declaration is provided in Chapter 4 "Module Addressing".

Automation Studio™ Support: See Automation Studio™ Help starting with V 1.40

Accessing screw-in modules is also explained in the sections "AF101" and "CPU".

The module CM211 is equipped with a maximum of two incremental encoders. The incremental encoders are distributed on slots 3 and 4.

Incremental encoder 1 (slot 3) with PLC 2003 CPU and remote slaves

Data access takes place using data and configuration words. The following table provides an overview of which data and configuration words are used for the first incremental encoder.

Data Access	VD Data Type	VD Module Type	VD Chan.	R	W	Description
Data word 0	WORD	Transp. In	0	●		Module status
Data word 1	INT32	Transp. In	2	●		Counter value
Configuration word 4	INT32	Transp. In	8	●		Counter value with pos. edge on the reference input ¹⁾
	INT32	Transp. Out	8		●	Threshold value 1 / min. latch difference ¹⁾
Configuration word 6	INT32	Transp. In	12	●		Counter value with neg. edge on the reference input ¹⁾
	INT32	Transp. Out	12		●	Threshold value 2 / force value ¹⁾
Configuration word 8	WORD	Transp. Out	16		●	Incremental encoder control ¹⁾
Configuration word 12	WORD	Transp. In	24	●		Module status
Configuration word 14	WORD	Transp. In	28	●		Module type
	WORD	Transp. Out	28		●	Module configuration

Table 29: CM211 variable declaration for incremental encoder operation using the CPU and remote slaves

1) Starting with Rev. D0

Incremental encoder 1 (Slot 3) with CAN slaves

Data access takes place using data and configuration words. The following table provides an overview of which data and configuration words are used for the first incremental encoder.

Data Access	VD Data Type	VD Module Type	VD Chan.	R	W	Description
Data word 0	INT32	Transp. In	0	●		Counter value
Data word 2	WORD	Transp. In	4	●		Module status
Configuration word 4	INT32	Transp. In	8	●		Counter value with pos. edge on the reference input ¹⁾
	INT32	Transp. Out	8		●	Threshold value 1 / min. latch difference ¹⁾
Configuration word 6	INT32	Transp. In	12	●		Counter value with neg. edge on the reference input ¹⁾
	INT32	Transp. Out	12		●	Threshold value 2 / force value ¹⁾
Configuration word 8	WORD	Transp. Out	16		●	Incremental encoder control ¹⁾
Configuration word 12	WORD	Transp. In	24	●		Module status
Configuration word 14	WORD	Transp. In	28	●		Module type
	WORD	Transp. Out	28		●	Module configuration

Table 30: CM211 variable declaration for incremental encoder operation using CAN slaves

1) Starting with Rev. D0



B&R 2000 users have to exchange the two counter status words so that the high word is first (Motorola format)

Access using CAN Identifier

Access via CAN Identifiers is used if the slave is being controlled by a device from another manufacturer. Access via CAN Identifiers is described in an example in Chapter 4, "Module Addressing". The transfer modes are explained in Chapter 5, "CAN Bus Controller Functions" .

In the example below, the combination module CM211 is accessed with module addresses 1 and 2.

Slot	CAN-ID ¹⁾	Word 1		Word 2		Word 3		Word 4
1	542	Not used						
2	543	Not used						
3	544	Counter LL	Counter ML	Counter MH	Counter HH	Status L	Status H	Not used
4	545	Not used						

Table 31: CM211 access using CAN identifier, incremental encoder operation

- 1) CAN-ID = 542 + (nd - 1) x 16 + (ma - 1) x 4 + (sl - 1)
- nd.....Node number for the CAN slaves = 1
- ma.....Module address = 1
- sl.....Slot number = 3



B&R 2000 users have to exchange the data so that the high data is first (Motorola format)
 For more information on ID allocation, see Chapter 5 , "CAN Bus Controller Functions".

Description of Data and Configuration Words

Data Word 0 (read)

Data word 0 includes the module status time constant for the counter value.

	Bit	Description
	12 - 15	x ... Not defined, masked out
	11	0 ... Counter value not taken 1 ... Counter value is taken with the first positive edge on the reference input
	10	0 ... Counter value not taken 1 ... Counter value is taken with the first negative edge on the reference input
	8 - 9	x ... Not defined, masked out
	7	0 ... Referencing is taking place 1 ... Counter is referenced (resetting takes place when the reference command is received)
	6	Changes state each time referencing takes place
	5	0 ... Supply voltage < 18 V 1 ... Supply voltage > 18 V, outputs OK
	4	Output status of the comparator
	3	Level of encoder input A
	2	Level of encoder input B
	1	Level of the reference enable switch
	0	Level of the reference pulse

Data Word 1 (read)

Counter Value MSW

Data Word 2 (read)

Counter Value LSW

Configuration Words 4+5 (read) - Starting with rev. D0

After setting bit 11 in configuration word 8, the configuration words receive the latched counter value with the first positive edge on the reference input. The value is valid if bit 11 is set in data word 0. The maximum delay, from the edge on the input to the value is latched, is 50 μ s.

Configuration Words 4+5 (write)

Either threshold value 1 or the minimum latch difference is defined with configuration words 4+5.

1) Threshold value 1 (32 Bit):

a) Number format 32 bit with sign:

Bit 10 in configuration word 14 (write) is set to 0.

Threshold value 1 must always be \leq threshold value 2 .

Threshold values are internally arranged in increasing order including sign.

b) Number format 32 bit without sign - cyclic operation:

Bit 10 in configuration word 14 (write) is set to 1.

The threshold values are not placed in order internally. The sign is not used in the comparator calculation.

2) Minimum Latch Difference (32 Bit) - Starting with Rev. D0: D0:

Definition of the minimum latch difference for latching counters. This is done using bit 8 in configuration word 8.

Configuration Words 6+7 (read) - Starting with rev. D0

After setting bit 10 in configuration word 8, the configuration words receive the latched counter value with the first negative edge on the reference input. The value is valid if bit 10 is set in data word 0. The maximum delay, from the edge on the input to the value is latched, is 50 μ s.

Configuration Words 6+7 (write)

Either threshold value 2 (32 bit) or the force value (32 bit) is defined with configuration words 6+7. The definition of the force value is possible starting with rev. D0. The force value is defined using bit 8 in configuration word 8. The maximum delay, until the the force value definition is accepted, is 1 ms.

Configuration Word 8 (read) - Starting with rev. D0 D0

The incremental encoder is configured using configuration word 8.

Bit	Description
14 - 15	0
13	0 ... No effect on the incremental encoder 1 ... Inverts the reference enable switch for forcing Using bit 13, the polarity of the reference enable switch can be inverted.
12	0 ... No effect on the incremental encoder 1 ... Forcing the counter with the reference enable switch With a positive edge on bit 12, bit 7 is deleted in data word 0 and positive edge creation for the reference enable switch is activated. When the edge is recognized, the counter is set to the predefined value (default 0). In data word 0, bit 7 is set and bit 6 is inverted. The precision is limited compared to latch operation.
11	0 ... Counter value not taken 1 ... Counter value is taken with the first positive edge on the reference input (see configuration words 4+5) 1) ¹⁾
10	0 ... Counter value not taken 1 ... Counter value is taken with the first negative edge on the reference input (see configuration words 6+7) ¹⁾
9	0/1 ... Start output state for the latch input filter With bit 9, the start condition for edge creation and filtering of the latch signal can be defined. If the state of bit 9 is not the same as the current state of the reference input, an edge change is recognized internally and evaluated using the filter.
8	0 ... No effect on the incremental encoder 1 ... With a positive edge, configuration words 4+5 are used as minimum latch value and configuration words 6+7 are used as force value
0 - 7	0

1) The counter value is only taken once. Bit 10 and bit 11 must be reset for the value to be taken again. Bit 10 and bit 11 can be set again in configuration word 8 after the corresponding bit in the module status bit has gone to 0.

Latching the counter value using the reference input:



Bit 0 in configuration word 14 must be 0. That means, the comparator is switched off.

General:

The same internal interrupts or inputs are used for referencing, comparator operation and latching the counter value. Therefore the following priority is defined:

1. Homing
2. Comparator
3. Latching

Make sure there is a clean transition between the types of operation. That means the respective control bits are not allowed to be activated at the same time.

Latching the counter value:

Latching is started by a positive edge on bit 10 or bit 11 in configuration word 8. The current counter value is taken as comparison value for the minimum latch difference.

1) Minimum latch difference is 0:

If the minimum latch difference is set to 0 (default), the counter value is latched immediately when the respective edge occurs on the reference input.

2) Minimum latch difference is not 0:

If the minimum latch difference is not set to 0, the counter value is placed in temporary memory when the respective edge occurs on the reference input.

- Difference > minimum latch difference:

If the difference between the value in temporary memory minus the comparison value is larger than the minimum latch difference, the value is accepted and bit 10 or bit 11 in data word 0 is set.

- Difference < minimum latch difference:

If the difference between the value in temporary memory minus the comparison value is smaller than the minimum latch difference, the value is not yet accepted. The comparison is made again when the next corresponding edge occurs on the reference input.

The value is only accepted and bit 10 or bit 11 in data word 0 is only set if the difference is larger than the minimum latch difference.

Configuration Word 12 (read)

Configuration word 12 contains the module status (current status unlatched). The module status is written to data word 0.

Configuration Word 14 (read)

The High Byte of configuration word 14 defines the module code.

																Bit	Description
																8 - 15	Module code = \$40
																0 - 7	x ...Not defined, masked out
0	1	0	0	0	0	0	0	0	x	x	x	x	x	x	x	x	x
15								8	7								0

Configuration word 14 (write)

The module is configured using configuration word 14.

Bit	Description
14 - 15	0
13	0 ... Incremental Encoder Operation
12	0 ... Incremental Encoder Operation
11	0 ... No effect on count direction 1 ... Count direction inverted as compared to counter wiring
10	0 ... Number format: 32 bit with sign 1 ... Number format: 32 bit without sign - cyclic operation In continuous operation, the internal order of the threshold values are kept. If a counter overflow occurs, the behavior of the comparator does not have to be changed. Comparator operation takes place without consideration of the sign.
8 - 9	0 ... Incremental encoder operation with 4-fold evaluation
7	0 ... No effect on reference pulse 1 ... Reference pulse is inverted. This setting is used for encoders with a high pulse.
6	0 ... Set counter immediately to 0. In data word 0 (module status), bit 7 is immediately set to 1 and the counter is cleared. 1 ... Counter remains functioning. In data word 0 (module status), bit 7 is immediately set to 0 (referencing required).
5	0 ... Ignore reference enable switch (referencing using reference pulse). Setting refers to bit 4 1 ... Actively switch reference enable switch (referencing using reference pulse and reference enable switch)
4	0 ... No effect on counter 1 ... Clear counter (reference)
3	0 ... Comparator off Output 1 is handled as defined in the variable declaration for digital outputs. 1 ... Comparator on
2	0 ... The comparator output is set to the level given in bit 0, if threshold value 1 \leq counter \leq threshold value 2 1 ... The comparator output is set to the inverted level given in bit 0, if threshold value 1 \leq counter \leq threshold value 2
1	0
0	Level of the comparator output

15 8 7 0

Incremental encoder 2 (slot 4) with PLC 2003 CPU and remote slaves

Data access takes place using data and configuration words. The following table provides an overview of which data and configuration words are used for the second incremental encoder.

Data Access	VD Data Type	VD Module Type	VD Chan.	R	W	Description
Data word 0	WORD	Transp. In	0	●		Module status
Data word 1	INT32	Transp. In	2	●		Counter value
Configuration word 4	INT32	Transp. In	8	●		Counter value with pos. edge on the reference input ¹⁾
	INT32	Transp. Out	8		●	Threshold value 1 ²⁾ / min. latch difference ¹⁾
Configuration word 6	INT32	Transp. In	12	●		Counter value with neg. edge on the reference input ¹⁾
	INT32	Transp. Out	12		●	Threshold value 2 ²⁾ / force value ¹⁾
Configuration word 8	WORD	Transp. Out	16		●	Incremental encoder control ¹⁾
Configuration word 12	WORD	Transp. In	24	●		Module status
Configuration word 14	WORD	Transp. In	28	●		Module Type
	WORD	Transp. Out	28		●	Module configuration

Table 32: CM211 variable declaration for incremental encoder operation using the CPU and remote slaves

- 1) Starting with Rev. D0
- 2) Starting with Rev. G0

Incremental encoder 2 (Slot 4) with CAN slaves

Data access takes place using data and configuration words. The following table provides an overview of which data and configuration words are used for the second incremental encoder.

Data Access	VD Data Type	VD Module Type	VD Chan.	R	W	Description
Data word 0	INT32	Transp. In	0	●		Counter value
Data word 2	WORD	Transp. In	4	●		Module status
Configuration word 4	INT32	Transp. In	8	●		Counter value with pos. edge on the reference input ¹⁾
	INT32	Transp. Out	8		●	Threshold value 1 ²⁾ / min. latch difference ¹⁾
Configuration word 6	INT32	Transp. In	12	●		Counter value with neg. edge on the reference input ¹⁾
	INT32	Transp. Out	12		●	Threshold value 2 ²⁾ / force value ¹⁾
Configuration word 8	WORD	Transp. Out	16		●	Incremental encoder control ¹⁾
Configuration word 12	WORD	Transp. In	24	●		Module status
Configuration word 14	WORD	Transp. In	28	●		Module Type
	WORD	Transp. Out	28		●	Module configuration

Table 33: CM211 variable declaration for incremental encoder operation using CAN slaves

- 1) Starting with Rev. D0
- 2) Starting with Rev. G0



B&R 2000 users have to exchange the two counter status words so that the high word is first (Motorola format)

Access using CAN Identifier

Access via CAN Identifiers is used if the slave is being controlled by a device from another manufacturer. Access via CAN Identifiers is described in an example in Chapter 4, "Module Addressing". The transfer modes are explained in Chapter 5, "CAN Bus Controller Functions".

In the example below, the combination module CM211 is accessed with module addresses 1 and 2.

Slot	CAN-ID ¹⁾	Word 1		Word 2		Word 3		Word 4
1	542	Not used						
2	543	Not used						
3	544	Not used						
4	545	Counter LL	Counter ML	Counter MH	Counter HH	Status L	Status H	Not used

Table 34: CM211 access using CAN identifier, incremental encoder operation

- 1) $CAN-ID = 542 + (nd - 1) \times 16 + (ma - 1) \times 4 + (sl - 1)$
 nd.....Node number for the CAN slaves = 1
 ma.....Module address = 1
 sl.....Slot number = 4



B&R 2000 users have to exchange the data so that the high data is first (Motorola format)

For more information on ID allocation, see Chapter 5, "CAN Bus Controller Functions".

Description of Data and Configuration Words

Data Word 0 (read)

Data word 0 includes the module status time constant for the counter value.

	Bit	Description
	12 - 15	x ... Not defined, masked out
	11	0 ... Counter value not taken 1 ... Counter value is taken with the first positive edge on the reference input
	10	0 ... Counter value not taken 1 ... Counter value is taken with the first negative edge on the reference input
	8 - 9	x ... Not defined, masked out
	7	0 ... Referencing is taking place 1 ... Counter is referenced (resetting takes place when the reference command is received)
	6	Changes state each time referencing takes place
	5	0 ... Supply voltage < 18 V 1 ... Supply voltage > 18 V, outputs OK
	4	x ... Not defined, masked out
	3	Level of encoder input A
	2	Level of encoder input B
	1	Level of the reference enable switch
	0	Level of the reference pulse

Data Word 1 (read)

Counter Value MSW

Data Word 2 (read)

Counter Value LSW

Configuration Words 4+5 (read) - Starting with rev. D0

After setting bit 11 in configuration word 8, the configuration words receive the latched counter value with the first positive edge on the reference input. The value is valid if bit 11 is set in data word 0. The maximum delay, from the edge on the input to the value is latched, is 50 µs.

Configuration Words 4+5 (write)

Either threshold value 1 or the minimum latch difference is defined with configuration words 4+5.

1) Threshold value 1 (32 bit) - Starting with rev. G0:

a) Number format 32 bit with sign:

Bit 10 in configuration word 14 (write) is set to 0.

Threshold value 1 must always be \leq threshold value 2 .

Threshold values are internally arranged in increasing order including sign.

b) Number format 32 bit without sign - cyclic operation:

Bit 10 in configuration word 14 (write) is set to 1.

The threshold values are not placed in order internally. The sign is not used in the comparator calculation.

2) Minimum Latch Difference (32 Bit) - Starting with Rev. D0: D0:

Definition of the minimum latch difference for latching counters. This is done using bit 8 in configuration word 8.

Configuration Words 6+7 (read) - Starting with rev. D0

After setting bit 10 in configuration word 8, the configuration words receive the latched counter value with the first negative edge on the reference input. The value is valid if bit 10 is set in data word 0. The maximum delay, from the edge on the input to the value is latched, is 50 μ s.

Configuration Words 6+7 (write)

Either threshold value 2 or the minimum force value is defined with configuration words 4+5.

1) Threshold value 2 (32 bit) - Starting with rev. G0:

2) Force Value (32 bit) - Starting with rev. D0:

The force value is defined using bit 8 in configuration word 8. The maximum delay, until the the force value definition is accepted, is 1 ms.

Configuration Word 8 (read) - Starting with rev. D0 D0

The incremental encoder is configured using configuration word 8.

Bit	Description
14 - 15	0
13	0 ... No effect on the incremental encoder 1 ... Inverts the reference enable switch for forcing Using bit 13, the polarity of the reference enable switch can be inverted.
12	0 ... No effect on the incremental encoder 1 ... Forcing the counter with the reference enable switch With a positive edge on bit 12, bit 7 is deleted in data word 0 and positive edge creation for the reference enable switch is activated. When the edge is recognized, the counter is set to the predefined value (default 0). In data word 0, bit 7 is set and bit 6 is inverted. The precision is limited compared to latch operation.
11	0 ... Counter value not taken 1 ... Counter value is taken with the first positive edge on the reference input (see configuration words 4+5) 1) ¹⁾
10	0 ... Counter value not taken 1 ... Counter value is taken with the first negative edge on the reference input (see configuration words 6+7) ¹⁾
9	0/1 ... Start output state for the latch input filter With bit 9, the start condition for edge creation and filtering of the latch signal can be defined. If the state of bit 9 is not the same as the current state of the reference input, an edge change is recognized internally and evaluated using the filter.
8	0 ... No effect on the incremental encoder 1 ... With a positive edge, configuration words 4+5 are used as minimum latch value and configuration words 6+7 are used as force value
0 - 7	0

1) The counter value is only taken once. Bit 10 and bit 11 must be reset for the value to be taken again. Bit 10 and bit 11 can be set again in configuration word 8 after the corresponding bit in the module status bit has gone to 0.

Latching the counter value using the reference input:



Bit 0 in configuration word 14 must be 0. That means, the comparator is switched off.

General:

The same internal interrupts or inputs are used for referencing, comparator operation and latching the counter value. Therefore the following priority is defined:

1. Homing
2. Comparator
3. Latching

Make sure there is a clean transition between the types of operation. That means the respective control bits are not allowed to be activated at the same time.

Latching the counter value:

Latching is started by a positive edge on bit 10 or bit 11 in configuration word 8. The current counter value is taken as comparison value for the minimum latch difference.

1) Minimum latch difference is 0:

If the minimum latch difference is set to 0 (default), the counter value is latched immediately when the respective edge occurs on the reference input.

2) Minimum latch difference is not 0:

If the minimum latch difference is not set to 0, the counter value is placed in temporary memory when the respective edge occurs on the reference input.

- Difference > minimum latch difference:

If the difference between the value in temporary memory minus the comparison value is larger than the minimum latch difference, the value is accepted and bit 10 or bit 11 in data word 0 is set.

- Difference < minimum latch difference:

If the difference between the value in temporary memory minus the comparison value is smaller than the minimum latch difference, the value is not yet accepted. The comparison is made again when the next corresponding edge occurs on the reference input.

The value is only accepted and bit 10 or bit 11 in data word 0 is only set if the difference is larger than the minimum latch difference.

Configuration Word 12 (read)

Configuration word 12 contains the module status (current status unlatched). The module status is written to data word 0.

Configuration Word 14 (read)

The High Byte of configuration word 14 defines the module code.

		Bit	Description														
		8 - 15	Module code = \$40														
		0 - 7	x ...Not defined, masked out														
0	1	0	0	0	0	0	0	x	x	x	x	x	x	x	x	x	x
15				8	7												0

Configuration Word 14 (write)

The module is configured using configuration word 14.

Bit	Description
14 - 15	0
13	0 ... Incremental Encoder Operation
12	0 ... Incremental Encoder Operation
11	0 ... No effect on count direction 1 ... Count direction inverted as compared to counter wiring
10	Starting with revision G0: 0 ... Number format: 32 bit with sign 1 ... Number format: 32 bit without sign - cyclic operation In continuous operation, the internal order of the threshold values are kept. If a counter overflow occurs, the behavior of the comparator does not have to be changed. Comparator operation takes place without consideration of the sign.
8 - 9	0 ... Incremental encoder operation with 4-fold evaluation
7	0 ... No effect on reference pulse 1 ... Reference pulse is inverted. This setting is used for encoders with a high pulse.
6	0 ... Set counter immediately to 0. In data word 0 (module status), bit 7 is immediately set to 1 and the counter is cleared. 1 ... Counter remains functioning. In data word 0 (module status), bit 7 is immediately set to 0 (referencing required).
5	0 ... Ignore reference enable switch (referencing using reference pulse). Setting refers to bit 4 1 ... Actively switch reference enable switch (referencing using reference pulse and reference enable switch)
4	0 ... No effect on counter 1 ... Clear counter (reference)
3	Starting with revision G0: 0 ... Comparator off Output 1 is handled as defined in the variable declaration for digital outputs. 1 ... Comparator on
2	Starting with revision G0: 0 ... The comparator output is set to the level given in bit 0, if threshold value 1 ≤ counter ≤ threshold value 2 1 ... The comparator output is set to the inverted level given in bit 0, if threshold value 1 ≤ counter ≤ threshold value 2
1	0
0	Starting with revision G0: Level of the comparator output

15 8 7 0

11.1.22 Variable Declaration for Event Counter Operation

The variable declaration is valid for the following controllers:

- CPU for the PLC 2003
- Remote I/O Bus Controller
- CAN Bus Controller

The variable declaration is made in PG2000. The variable declaration is provided in Chapter 4 "Module Addressing".

Automation Studio™ Support: See Automation Studio™ Help starting with V 1.40

Accessing screw-in modules is also explained in the sections "AF101" and "CPU".

The module CM211 is equipped with a maximum of two event counters. The event counters are distributed on slots 3 and 4.

Event Counter 1 and 2 (Slot 3)

Data access takes place using data and configuration words. The following table provides an overview of which data and configuration words are used for event counters 1 and 2.

Data Access	VD Data Type	VD Module Type	VD Chan.	R	W	Description
Data word 0	WORD	Transp. In	0	●		Module status
Data word 1	WORD	Transp. In	2	●		Counter value of counter 1
Data word 2	WORD	Transp. In	4	●		Counter value of counter 2
Configuration word 5	WORD	Transp. Out	10		●	Threshold value 1 for counter 2
Configuration word 7	WORD	Transp. Out	14		●	Threshold value 2 for counter 2
Configuration word 14	WORD	Transp. In	28	●		Module type
	WORD	Transp. Out	28		●	Module configuration

Table 35: CM211 variable declaration for event counter 1 and 2 (slot 3)

Access using CAN Identifier

Access via CAN Identifiers is used if the slave is being controlled by a device from another manufacturer. Access via CAN Identifiers is described in an example in Chapter 4, "Module Addressing". The transfer modes are explained in Chapter 5, "CAN Bus Controller Functions" .

In the example below, the combination module CM211 is accessed with module addresses 1 and 2.

Slot	CAN-ID ¹⁾	Word 1	Word 2	Word 3	Word 4			
1	542	Not used						
2	543	Not used						
3	544	Counter 2 L	Counter 2 H	Counter 1 L	Counter 1 H	Status L	Status H	Not used
4	545	Not used						

Table 36: CM211 access using the CAN identifier, event counter 1 and 2 (slot 3)

- 1) CAN-ID = 542 + (nd - 1) x 16 + (ma - 1) x 4 + (sl - 1)
- nd.....Node number for the CAN slaves = 1
- ma.....Module address = 1
- sl.....Slot number = 3



B&R 2000 users have to exchange the data so that the high data is first (Motorola format)

For more information on ID allocation, see Chapter 5 , "CAN Bus Controller Functions".

Description of Data and Configuration Words

Data Word 0 (read)

Data word 0 includes the module status time constant for both counter values.

Bit	Description
6 - 15	x ... Not defined, masked out
5	0 ... Supply voltage < 18 V 1 ... Supply voltage > 18 V, outputs OK
4	Output status of the comparator
3	Level of the encoder input for counter 1
2	Level of the encoder input for counter 2
0 - 1	x ... Not defined, masked out

Data Word 1 (read)

Counter value of counter 1.

Data Word 2 (read)

Counter value of counter 2.

Configuration Word 5 (write)

Threshold value 1 (16 Bit) for counter 2:

a) Number format: 16 bit without sign

Bit 10 in configuration word 14 (write) is set to 0.

Threshold value 1 must always be \leq threshold value 2 .

Threshold values are internally arranged in increasing order. The sign is ignored.

b) Number format: 16 bit without sign - cyclic operation

Bit 10 in configuration word 14 (write) is set to 1.

The threshold values are not placed in order internally. The sign is ignored.

Configuration Word 7 (write)

Threshold value 2 (16 Bit) for counter 2.

Configuration Word 14 (read)

The High Byte of configuration word 14 defines the module code.

																Bit	Description
																8 - 15	Module code = \$40
																0 - 7	x ...Not defined, masked out
0	1	0	0	0	0	0	0	x	x	x	x	x	x	x	x		
15							8	7									0

Configuration Word 14 (write)

The module is configured using configuration word 14.

																Bit	Description
																14 - 15	0
																13	0 ... Event Counter Operation
																12	1 ... Event Counter Operation
																11	0 ... No effect on count direction 1 ... Count direction inverted as compared to counter wiring
																10	0 ... Number format: 16 bit without sign 1 ... Number format: 16 bit without sign - cyclic operation In continuous operation, the internal order of the threshold values are kept. If a counter overflow occurs, the behavior of the comparator does not have to be changed.
																9	0
																8	0 ... Counter 1 and 2: Only count positive edges 1 ... Counter 1 and 2: Count both edges
																6 - 7	0
																5	0 ... No effect on counter 2 1 ... Immediately clear counter 2
																4	0 ... No effect on counter 1 1 ... Immediately clear counter 1
																3	0 ... Comparator off Output 1 is handled as defined in the variable declaration for digital outputs. 1 ... Comparator on
																2	0 ... The comparator output is set to the level given in bit 0, if threshold value 1 ≤ counter ≤ threshold value 2 1 ... The comparator output is set to the inverted level given in bit 0, if threshold value 1 ≤ counter ≤ threshold value 2
																1	0
																0	Level of the comparator output
0	0	0	1														
15						8	7								0		

Event Counter 3 (Slot 4)

Data access takes place using data and configuration words. The following table provides an overview of which data and configuration words are used for event counter 3.

Data Access	VD Data Type	VD Module Type	VD Chan.	R	W	Description
Data word 0	WORD	Transp. In	0	●		Module status
Data word 1	WORD	Transp. In	2	●		Counter value of counter 3
Configuration word 5	WORD	Transp. Out	10		●	Threshold value 1 for counter 3 ¹⁾
Configuration word 7	WORD	Transp. Out	14		●	Threshold value 2 for counter 3 ¹⁾
Configuration word 14	WORD	Transp. In	28	●		Module type
	WORD	Transp. Out	28		●	Module configuration

Table 37: CM211 variable declaration for event counter 3 (slot 4)

1) Starting with Rev. G0

Access using CAN Identifier

Access via CAN Identifiers is used if the slave is being controlled by a device from another manufacturer. Access via CAN Identifiers is described in an example in Chapter 4, "Module Addressing". The transfer modes are explained in Chapter 5, "CAN Bus Controller Functions".

In the example below, the combination module CM211 is accessed with module addresses 1 and 2.

Slot	CAN-ID ¹⁾	Word 1	Word 2	Word 3	Word 4		
1	542	Not used					
2	543	Not used					
3	544	Not used					
4	545	Not used	Counter 3 L	Counter 3 H	Status L	Status H	Not used

Table 38: CM211 access using the CAN identifier, event counter 3 (slot 4)

1) $CAN-ID = 542 + (nd - 1) \times 16 + (ma - 1) \times 4 + (sl - 1)$
 nd.....Node number for the CAN slaves = 1
 ma.....Module address = 1
 sl.....Slot number = 4



B&R 2000 users have to exchange the data so that the high data is first (Motorola format)

For more information on ID allocation, see Chapter 5, "CAN Bus Controller Functions".

Description of Data and Configuration Words

Data Word 0 (read)

Data word 0 includes the module status time constant for the counter value.

																Bit	Description	
																4 - 15	x ... Not defined, masked out	
																3	Level of the encoder input for counter 3	
																0 - 2	x ... Not defined, masked out	
x	x	x	x	x	x	x	x	x	x	x	x	x	x	x	x	x	x	x
15																		0

Data Word 1 (read)

Counter value of counter 3.

Configuration Word 5 (read) - Starting with rev. D0 G0

Threshold value 1 (16 Bit) for counter 3:

- a) Number format: 16 bit without sign
 - Bit 10 in configuration word 14 (write) is set to 0.
 - Threshold value 1 must always be \leq threshold value 2 .
 - Threshold values are internally arranged in increasing order. The sign is ignored.
- b) Number format: 16 bit without sign - cyclic operation
 - Bit 10 in configuration word 14 (write) is set to 1.
 - The threshold values are not placed in order internally. The sign is ignored.

Configuration Word 7 (read) - Starting with rev. D0 G0

Threshold value 2 (16 Bit) for counter 3.

Configuration Word 14 (read)

The High Byte of configuration word 14 defines the module code.

																Bit	Description
																8 - 15	Module code = \$40
																0 - 7	x ...Not defined, masked out
0	1	0	0	0	0	0	0	x	x	x	x	x	x	x	x		
15								8	7							0	

Configuration Word 14 (write)

The module is configured using configuration word 14.

		Bit	Description													
		14 - 15	0													
		13	0 ... Event Counter Operation													
		12	1 ... Event Counter Operation													
		11	0 ... No effect on count direction 1 ... Count direction inverted as compared to counter wiring													
		10	Starting with revision G0: 0 ... Number format: 16 bit without sign 1 ... Number format: 16 bit without sign - cyclic operation In continuous operation, the internal order of the threshold values are kept. If a counter overflow occurs, the behavior of the comparator does not have to be changed.													
		9	0													
		8	0 ... Counter 3: Only count positive edges 1 ... Counter 3: Count both edges													
		5 - 7	0													
		4	0 ... No effect on counter 3 1 ... Immediately clear counter 3													
		3	Starting with revision G0: 0 ... Comparator off Output 1 is handled as defined in the variable declaration for digital outputs. 1 ... Comparator on													
		2	Starting with revision G0: 0 ... The comparator output is set to the level given in bit 0, if threshold value 1 ≤ counter ≤ threshold value 2 1 ... The comparator output is set to the inverted level given in bit 0, if threshold value 1 ≤ counter ≤ threshold value 2													
		1	0													
		0	Starting with revision G0: Level of the comparator output													
15	0	0	0	1	0	0	0	0	0	0	0	0	0	0	0	0

11.1.23 Variable Declaration for Gate and Period Measurement

The variable declaration is valid for the following controllers:

- CPU for the PLC 2003
- Remote I/O Bus Controller
- CAN Bus Controller

The variable declaration is made in PG2000. The variable declaration is provided in Chapter 4 "Module Addressing".

Automation Studio™ Support: See Automation Studio™ Help starting with V 1.40

Accessing screw-in modules is also explained in the sections "AF101" and "CPU".

The module CM211 is equipped with a maximum of three channels for gate and period measurement. The channels are distributed on slots 3 and 4.

Gate and Period Measurement 1 and 2 (Slot 3)

Data access takes place using data and configuration words. The following table provides an overview of which data and configuration words are used.

Data Access	VD Data Type	VD Module Type	VD Chan.	R	W	Description
Data word 0	WORD	Transp. In	0	●		Module status
Data word 1	WORD	Transp. In	2	●		Counter value gate / period 1
Data word 2	WORD	Transp. In	4	●		Counter value gate / period 2
Configuration word 14	WORD	Transp. In	28	●		Module type
	WORD	Transp. Out	28		●	Module configuration

Table 39: CM211 variable declaration for gate and period measurement (slot 3)

Access using CAN Identifier

Access via CAN Identifiers is used if the slave is being controlled by a device from another manufacturer. Access via CAN Identifiers is described in an example in Chapter 4, "Module Addressing". The transfer modes are explained in Chapter 5, "CAN Bus Controller Functions" .

In the example below, the combination module CM211 is accessed with module addresses 1 and 2.

Slot	CAN-ID ¹⁾	Word 1		Word 2		Word 3		Word 4
1	542	Not used						
2	543	Not used						
3	544	Counter 2 L	Counter 2 H	Counter 1 L	Counter 1 H	Status L	Status H	Not used
4	545	Not used						

Table 40: CM211 access using the CAN identifier gate and period measurement 3 (slot 3)

- 1) CAN-ID = 542 + (nd - 1) x 16 + (ma - 1) x 4 + (sl - 1)
- nd.....Node number for the CAN slaves = 1
- ma.....Module address = 1
- sl.....Slot number = 3



B&R 2000 users have to exchange the data so that the high data is first (Motorola format)

For more information on ID allocation, see Chapter 5 , "CAN Bus Controller Functions".

Description of Data and Configuration Words

Data Word 0 (read)

Data word 0 includes the module status time constant for both counter values.

																Bit	Description
																3 - 15	x ... Not defined, masked out
																2	Level of the encoder input for gate / period 1
																1	x ... Not defined, masked out
																0	Level of the encoder input for gate / period 2
x	x	x	x	x	x	x	x	x	x	x	x	x	x	x	x		
15							8	7									0

Data Word 1 (read)

Counter Value Gate / Period 1.

Data Word 2 (read)

Counter Value Gate / Period 2.

Configuration Word 14 (read)

The High Byte of configuration word 14 defines the module code.

																Bit	Description
																8 - 15	Module code = \$40
																0 - 7	x ...Not defined, masked out
0	1	0	0	0	0	0	0	x	x	x	x	x	x	x	x		
15							8	7									0

Configuration Word 14 (write)

The module is configured using configuration word 14.

Bit	Description
14 - 15	0
13	1 ... Gate / period measurement
12	1 ... Gate / period measurement
11	0 ... Channel 2: No effect on counter value 1 ... Channel 2: Set counter value to zero (retrigger)
10	0 ... Channel 1: No effect on counter value 1 ... Channel 1: Set counter value to zero (retrigger)
8 - 9	0
7	0 ... Channel 2: Gate measurement 1 ... Channel 2: Period measurement
4 - 6	Channel 2: Definition of counter frequency 0 ... Internal 16 MHz 1 ... Internal 4 MHz 2 ... Internal 1 MHz 3 ... Internal 250 kHz 4 ... External only rising edges 5 ... External, both edges
3	0 ... Channel 1: Gate measurement 1 ... Channel 1: Period measurement
0 - 2	Channel 1: Definition of counter frequency 0 ... Internal 16 MHz 1 ... Internal 4 MHz 2 ... Internal 1 MHz 3 ... Internal 250 kHz 4 ... External only rising edges 5 ... External, both edges

Gate and Period Measurement 3 (Slot 4)

Data access takes place using data and configuration words. The following table provides an overview of which data and configuration words are used.

Data Access	VD Data Type	VD Module Type	VD Chan.	R	W	Description
Data word 0	WORD	Transp. In	0	●		Module status
Data word 1	WORD	Transp. In	2	●		Counter value gate / period 3
Configuration word 14	WORD	Transp. In	28	●		Module type
	WORD	Transp. Out	28		●	Module configuration

Table 41: CM211 variable declaration for gate and period measurement (slot 4)

Access using CAN Identifier

Access via CAN Identifiers is used if the slave is being controlled by a device from another manufacturer. Access via CAN Identifiers is described in an example in Chapter 4, "Module Addressing". The transfer modes are explained in Chapter 5, "CAN Bus Controller Functions".

In the example below, the combination module CM211 is accessed with module addresses 1 and 2.

Slot	CAN-ID ¹⁾	Word 1	Word 2	Word 3	Word 4		
1	542	Not used					
2	543	Not used					
3	544	Not used					
4	545	Not used	Counter 3 L	Counter 3 H	Status L	Status H	Not used

Table 42: CM211 access using the CAN identifier gate and period measurement 4 (slot 3)

- 1) CAN-ID = 542 + (nd - 1) x 16 + (ma - 1) x 4 + (sl - 1)
- nd.....Node number for the CAN slaves = 1
- ma.....Module address = 1
- sl.....Slot number = 4



B&R 2000 users have to exchange the data so that the high data is first (Motorola format)

For more information on ID allocation, see Chapter 5, "CAN Bus Controller Functions".

Description of Data and Configuration Words

Data Word 0 (read)

Data word 0 includes the module status time constant for the counter value.

Bit	Description
1 - 15	x ... Not defined, masked out
0	Level of the encoder input for gate / period 3

15
8 7
0

xxxxxxxxxxxxxxxxxxxx

Data Word 1 (read)

Counter Value Gate / Period 3.

Configuration Word 14 (read)

The High Byte of configuration word 14 defines the module code.

		Bit	Description													
		8 - 15	Module code = \$40													
		0 - 7	x ...Not defined, masked out													
0	1	0	0	0	0	0	0	0	x	x	x	x	x	x	x	x
15									8	7						0

Configuration Word 14 (write)

The module is configured using configuration word 14.

		Bit	Description													
		14 - 15	0													
		13	1 ... Gate / period measurement													
		12	1 ... Gate / period measurement													
		11	0													
		10	0 ... Channel 3: No effect on counter value 1 ... Channel 3: Set counter value to zero (retrigger)													
		4 - 9	0													
		3	0 ... Channel 3: Gate measurement 1 ... Channel 3: Period measurement													
		0 - 2	Channel 3: Definition of counter frequency 0 ... Internal 16 MHz 1 ... Internal 4 MHz 2 ... Internal 1 MHz 3 ... Internal 250 kHz 4 ... External only rising edges 5 ... External, both edges													
0	0	1	1	0	0	0	0	0	0	0						
15									8	7						0

11.1.24 Variable Declaration for Digital Inputs/Outputs

The variable declaration is valid for the following controllers:

- CPU for the PLC 2003
- Remote I/O Bus Controller
- CAN Bus Controller

The variable declaration is made in PG2000. The variable declaration is provided in Chapter 4 "Module Addressing".

Automation Studio™ Support: See Automation Studio™ Help starting with V 1.40

Name	VD Data Type	VD Module Type	VD Chan.	R	W	Description
Digital inputs 1 - 8	BIT	Digit. In	1 ... 8	●		Level of the digital inputs
Digital outputs 1 - 8	BIT	Digit. Out	1 ... 8		●	Level of the digital outputs
Module status	BYTE	Status In	0	●		Module status

Table 43: CM211 variable declaration digital inputs/outputs

Access using CAN Identifier

Access via CAN Identifiers is used if the slave is being controlled by a device from another manufacturer. Access via CAN Identifiers is described in an example in Chapter 4, "Module Addressing". The transfer modes are explained in Chapter 5, "CAN Bus Controller Functions".

Digital Inputs

A maximum of eight digital I/O modules can be run in the packed mode.

The CM211 modules uses two module addresses. If two CM211 modules are used, only four additional digital I/O modules can be used.

The following example shows the structure of the CAN object if two CM211 and four DI435 modules are used.

CAN-ID ¹⁾	Byte 1	Byte 2	Byte 3	Byte 4	Byte 5	Byte 6	Byte 7	Byte 8
286	CM211 Not used	CM211 I 1 - 8	CM211 Not used	CM211 I 1 - 8	DI435	DI435	DI435	DI435

Table 44: CM211 access using CAN identifier, digital inputs, packed

1) CAN-ID = 286 + (nd - 1) x 4
nd.....Node number for CAN slaves = 1

A maximum of four digital I/O module can be run in unpacked mode.

The following example shows the structure of the CAN object if one CM211 and two DI435 modules are used.

Module	CAN-ID ¹⁾	Byte
CM211	286	Not used
	287	Inputs 1 - 8
DI435	288	Inputs 1 - 8
DI435	289	Inputs 1 - 8

Table 45: CM211 access using CAN identifier, digital inputs, unpacked

- 1) $CAN-ID = 286 + (nd - 1) \times 4 + (ma - 1)$
 nd.....Node number for CAN slaves = 1
 ma.....Module address for the digital I/O module = 1 - 4

Digital Outputs

A maximum of eight digital I/O modules can be run in the packed mode.

The CM211 modules uses two module addresses. If two CM211 modules are used, only four additional digital I/O modules can be used.

The following example shows the structure of the CAN object if two CM211 and four DO722 modules are used.

CAN-ID ¹⁾	Byte 1	Byte 2	Byte 3	Byte 4	Byte 5	Byte 6	Byte 7	Byte 8
414	CM211 Not used	CM211 O 1 - 8	CM211 Not used	CM211 O 1 - 8	DO722	DO722	DO722	DO722

Table 46: CM211 access using CAN identifier, digital outputs, packed

- 1) $CAN-ID = 414 + (nd - 1) \times 4$
 nd.....Node number for CAN slaves = 1

A maximum of four digital I/O module can be run in unpacked mode.

The following example shows the structure of the CAN object if one CM211 and two DO722 modules are used.

Module	CAN-ID ¹⁾	Byte
CM211	414	Not used
	415	Outputs 1 - 8
DO722	416	Outputs 1 - 8
DO722	417	Outputs 1 - 8

Table 47: CM211 access using CAN identifier, digital outputs, unpacked

- 1) CAN-ID = 414 + (nd - 1) x 4 + (ma - 1)
- nd.....Node number for CAN slaves = 1
- ma.....Module address for the digital I/O module = 1 - 4

For more information on ID allocation, see Chapter 5 , "CAN Bus Controller Functions".

Module status

Bit	Description
7	0 ... No supply voltage or supply voltage too low for digital inputs/outputs 1 ... Module voltage OK
6	Digital module = 0
5	0 ... No error 1 ... Error (short circuit, over-temperature, etc.)
0 - 4	Module code = \$17

7	0	1	0	1	1	1	1	0
---	---	---	---	---	---	---	---	---

