

Directional Control Valves

DG3*-H8; 30 and 10 Series, Pilot Operated

DG17*-H8; 30 and 10 Series, Manually Operated

DG5*-H8; 50 and 30 Series, Solenoid Controlled, Pilot Operated

ISO 4401 Size 08

Typical Section

DG5*-H8-2C Spring-Centered Valve Example

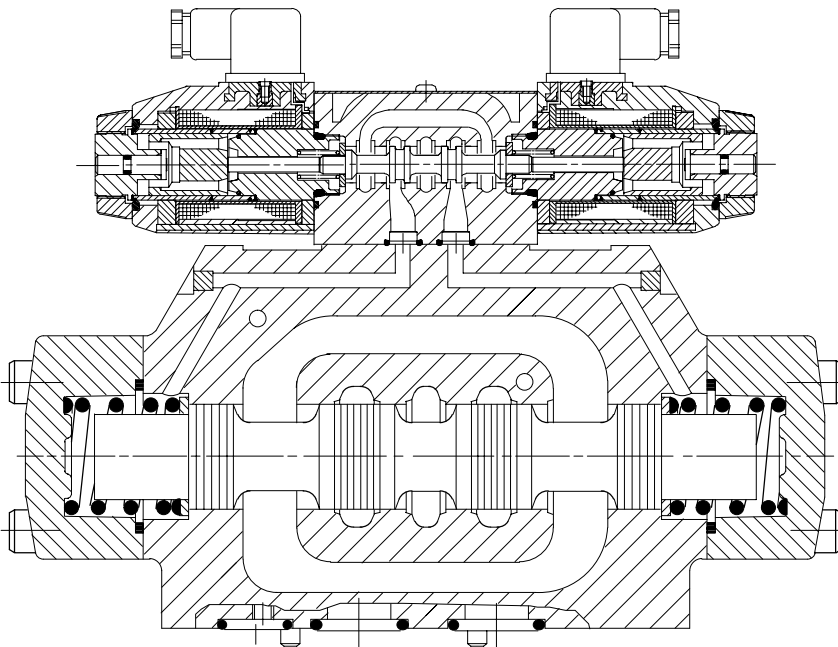

Basic Characteristics

Mounting Surface mounting

Max. pressure:

DG*S 210 bar (3000 psi)

DG*V 350 bar (5000 psi)

Max. flow 700 L/min (185 USgpm)

General Description

DG**-H8 valves are used primarily for controlling the starting, stopping and direction of fluid flow.

Basically, six series of valves are available grouped into DG*S moderate pressure versions and DG*V high pressure versions. There is a choice of up to 18 different spools, dependent on valve configuration. These include meter-in and meter-out spools, and regeneration types that can obviate extra valves essential in traditional circuit arrangements. All spools have been designed to provide good low shock, fast response characteristics

which can be enhanced by optional stroke and/or pilot choke adjustments.

Models include spring offset, spring centered, pressure centered and detented versions. All are available with the option of an integral P-port minimum-pilot-pressure generator. DG5* valves can be arranged for internal or external pilot pressure and/or drain connections.

Features and Benefits

- High pressure and flow capability for maximum cost-effectiveness.
- Low headloss to minimize power wastage.
- Low shock characteristics to maximize machine life.
- Facility to change solenoid coils without disturbing the hydraulic envelope.
- The many optional features, particularly for DG5* valves, permit matching to virtually every application within the valve's power capacity.

Functional Symbols

DG3*-H8 Pilot Operated Models

Comprehensive and simplified symbols.

Spring Offset, End-to-End, DG3*-H8-*A

Spool types: 0, 2, 6, 9, 52, 521, X2▲, Y2▲

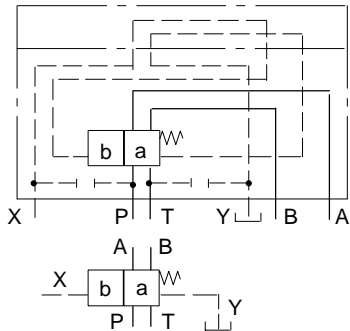

Spring Offset, End-to-End, Opposite Hand, DG3*-H8-*AL

Spool types: 0, 2, 6, 9, 52, 521, X2▲, Y2▲

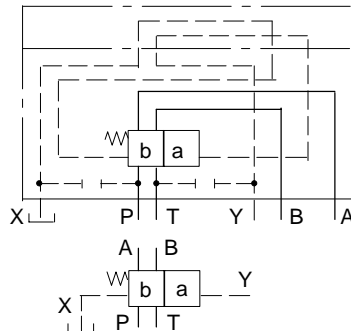

Spring Centered, DG3*-H8-*C

Spool types: All ▲

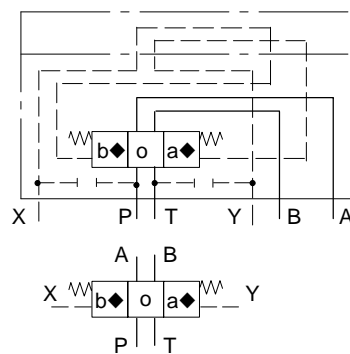

Pressure Centered, DG3*-H8-*D

Spool types: All ▲

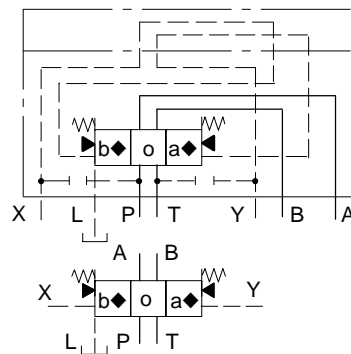

DG3-H8 Options

The following are shown in a DG3*-H8-*C example:

1. Pilot choke module
2. Minimum pilot pressure generator
3. Stroke adjusters at either or at both ends (shown at both ends in example)

One or more options can be built into any DG3 series valve.

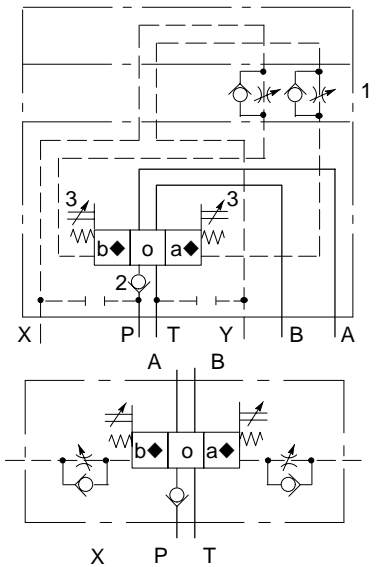

DG5*-H8, Solenoid Controlled, Pilot Operated Models

Comprehensive and simplified symbols, shown configured for external pilot supply and internal drain.

Spring Offset, End-to-End, DG5*-H8-*A

Spool types: 0, 2, 6, 9, 52, 521, X2▲, Y2▲

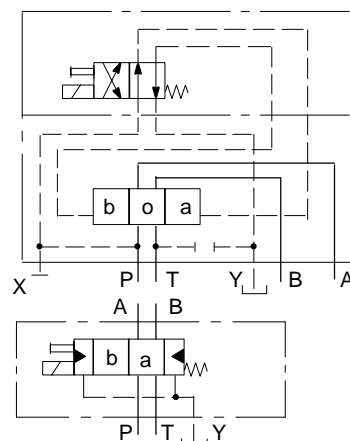

Spring Offset, End-to-End, Opposite Hand, DG5*-H8-*AL

Spool types: 0, 2, 6, 9, 52, 521, X2▲, Y2▲

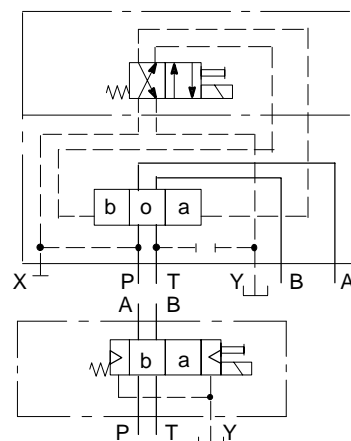

- ◆ "a" and "b" interchanged for spool types 4 and 8.
- ▲ "X" and "Y" spools require a stroke adjuster at one or both ends, dependent on the application, to limit stroke towards "a" and/or "b".

Spring Offset, End-to-Center

Models Spool types
 DG5*-H8-*B 0, 2, 521, X2▲, Y2▲
 DG5*-H8-*BL 4, 8

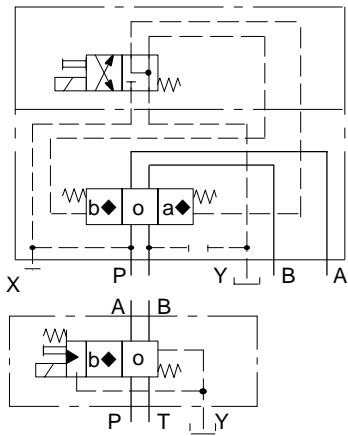

Spring Offset, End-to-Center, Opposite Hand

Models Spool types
 DG5*-H8-*B 4, 8
 DG5*-H8-*BL 0, 2, 521, X2▲, Y2▲

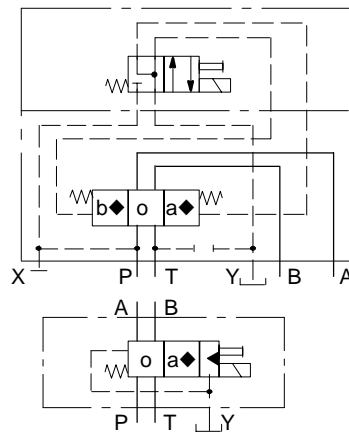

Spring Centered, DG5*-H8-*C

Spool types: All

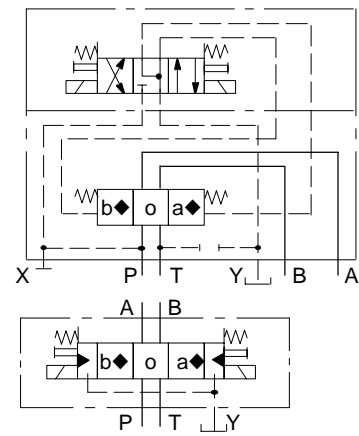

Pressure Centered, DG5*-H8-*D

Spool types: All

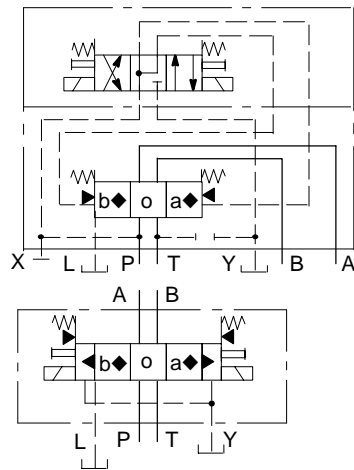

Detented, DG5*-H8-*N

Spool types: 0, 2, 6, 9, 52, 521, X2▲, Y2▲

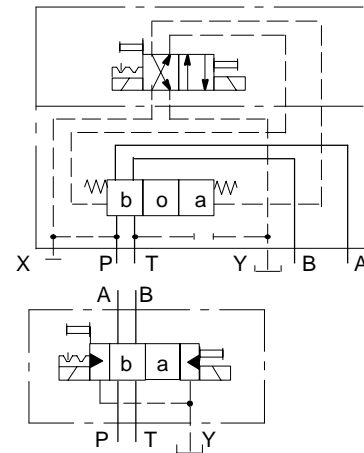

DG5*-H8 Options

The following are shown in a DG5*-H8-*C example:

1. Pilot choke module
2. Minimum pilot pressure generator
3. Stroke adjusters, at either or at both ends (shown at both ends in example)
4. External pilot connection
5. Internal drain

One or more options can be built into any DG5 series valve, the only exception being that the internal drain option is not available with DG5*-H8-*D (pressure centered) valves.

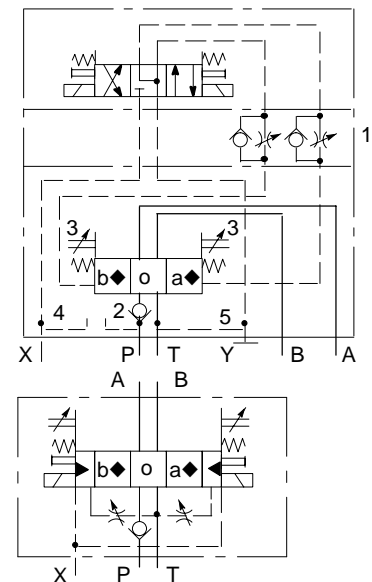

- ◆ "a" and "b" interchanged for spool types 4 and 8.
- ▲ "X" and "Y" spools require a stroke adjuster at one or both ends, dependent on the application, to limit stroke towards "a" and/or "b".

DG17*-H8 Hand-Lever Operated Models
Comprehensive and simplified symbols.

Spring Offset, End-to-End, DG17*-H8-*A

Spool types: 0, 2, 6

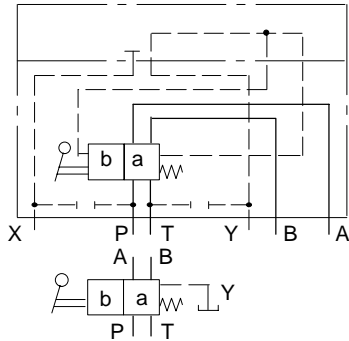

Spring Offset, End-to-End, Opposite Hand, DG17*-H8-*AL

Spool types: 0, 2, 6

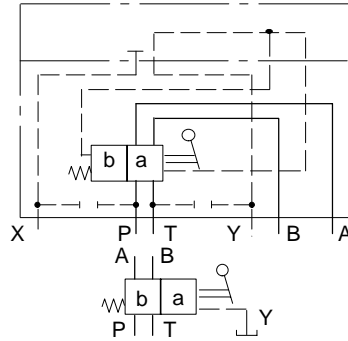

Spring Centered, DG17*-H8-*C

Spool types: 0, 2, 4, 6, 8, 33

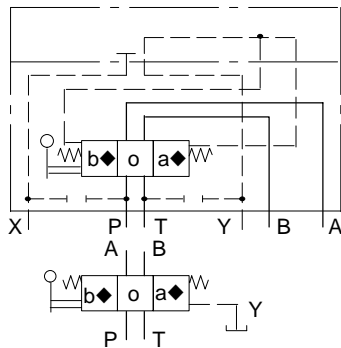

Detented, DG17*-H8-*N

Spool types: 0, 2, 4, 6, 8, 33

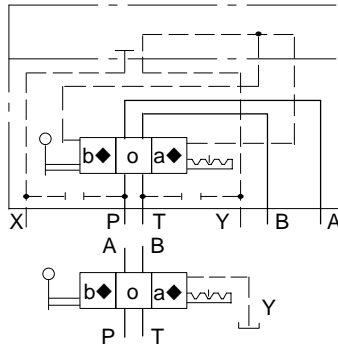

◆ "a" and "b" interchanged for spool types 4 and 8.

Symbols on Nameplates

Typical illustrations for:

DG3*-H8-2D-1

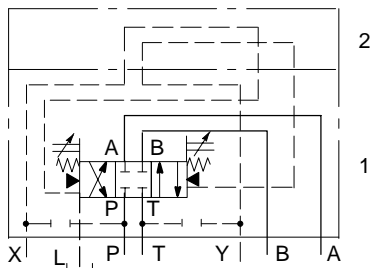

1. On main stage
2. On cover plate

DG5*-H8-3C-2-E-T*

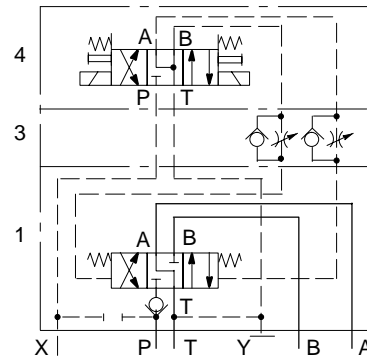

1. On main stage
2. On pilot choke module
3. On pilot stage valve
4. On pilot stage valve

Notes:

- a. For clarity pilot lines (dotted lines in illustrations) are omitted from the main-stage nameplate.
- b. Where a minimum pilot pressure generator (check valve symbol) is provided the letter P is omitted from the nameplate for clarity.

Spool Types

Shown in 3-position form, plus 2 transients

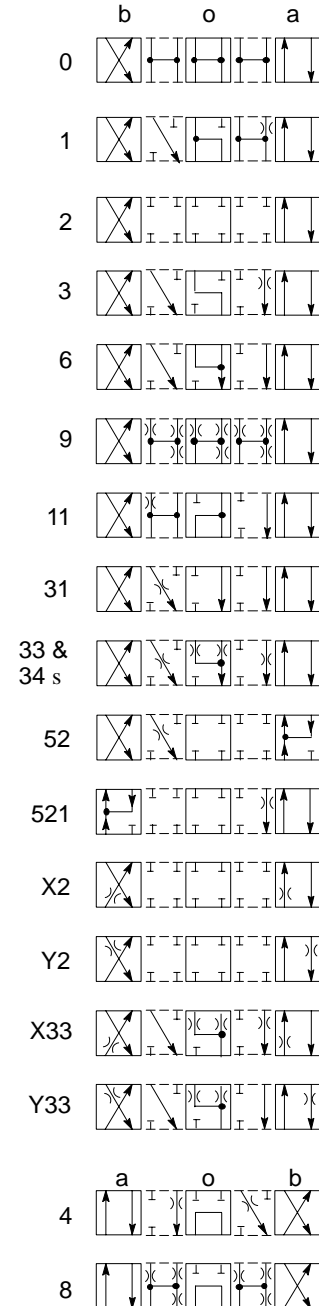

Notes:

1. In the detailed and simplified symbols on this and the previous pages, the transient positions are omitted for simplicity.
 2. In certain 2-position valves, the "o" position becomes an additional transient, i.e. in DG5*-H8-*A(L) and DG5*-H8-*N valves.
- ▲ The performance of the "33" and "34" spools differ only in the center position. Your Vickers representative can provide further details.

Application Notes

Pilot Pressure

- a. Pilot pressure must always exceed tank line pressure by at least the requisite minimum pilot pressure. This also applies when combining open-center spools (0, 1, 4, 8, 9 and 11) with internal pilot pressure, but they should be used only with externally drained valves.
- b. Internally drained valves may be used only when surges in the tank line cannot possibly overcome the minimum pilot pressure differential referred to above. When the possibility of pressure surges in the tank line exist, externally drained valves are recommended.
- c. When DG5*-H8-*N valves are de-energized the pilot and main spools remain in the last selected position, provided that pilot pressure is maintained. If pilot pressure fails, or falls below the minimum, the main spool will spring center.

Caution: Because of this in-built feature the flow conditions of the center position must be selected with care, for the effect on both the direction of flow and the pilot pressure.

Minimum-Pilot-Pressure Generator Option

Can be built into the P-port to create a specific minimum pilot pressure differential where internal pilot pressure is required with open-centered spools, i.e. 0, 1, 4, 8, 9 and 11.

Stroke Adjustment Options

These control the maximum opening of the main spool/body passages by adjusting the limits of spool stroke. By this means, the response time and the pressure drop across the valve for any particular flow rate can be controlled. Stroke adjusters can be fitted at either or both ends of the main-stage valve for adjusting the stroke in one or both directions. One use of stroke adjusters is for controlling the metering characteristics of "X*" or "Y*" type spools. (See model code 5.)

Pilot Choke Adjustment Options

These provide a meter-out flow control system to the fluid in the pilot chambers of main-stage valves. This allows the velocity of the main-stage spool to be controlled, thereby reducing transient shock condition. For optimum results, a constant reduced pilot pressure is recommended.

Control Data, General

- a. Dependent on the application and the system filtration, any sliding spool valve, if held shifted under pressure for long periods of time, may stick and not move readily due to fluid residue formation. It may therefore need to be cycled periodically to prevent this from happening.
- b. Surges of fluid in a common drain line serving two or more valves can be of sufficient magnitude to cause inadvertent shifting of the spools. It is recommended that circuit protection be used, such as separate drain lines.
- c. Control by stroke adjusters, pilot chokes and minimum-pilot-pressure generator options is described far left.

Model Code

For pilot operated valves:

(F3-)DG3* -H8-* ** (-**)(-*)-****

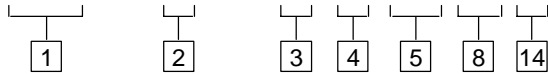

For hand-lever operated valves:

(F3-)DG17* -H8- ** -****

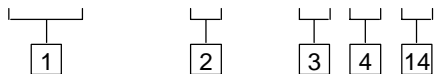

For solenoid controlled, pilot operated valves:

(F3-)DG5* -H8-* ** (-**)(-E)(-T)(-*)(-*)-(V)M-***** (L) -* 5 -****

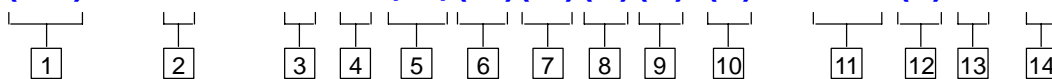

1 Fluid compatibility

Blank = Antiwear hydraulic oil (class L-HM), invert emulsion (class L-HFB), or water glycol (class L-HFC)

F3 = As above or phosphate ester (class L-HFD)

Note: For further information see "Hydraulic Fluids" section seven pages on.

2 Pressure rating

S = 210 bar (3000 psi)

V = 350 bar (5000 psi)

3 Spool type

See "Functional Symbols" section commencing four pages back

4 Spool spring arrangement

A = Spring offset, end-to-end (P to B when operated)

AL = As "A" but left-hand build (P to A when operated)

B = Spring offset, end-to-center (P to B when operated)▲

BL = As "B" but left-hand build (P to A when operated)▲

C = Spring centered

D = Pressure centered▼

N = Two-position detented

▲ DG5* option. Same function from DG3*-H8-C valves by alternating pilot supply to one port (X or Y) and permanently draining the other.

▼ Option for DG3* and DG5* models only.

5 Spool control

1 = Stroke adjustment at both ends▼

2 = Pilot choke adjustment both ends

3 = "1" and "2" combined▼

7 = Stroke adjustment, port A end only■

8 = Stroke adjustment, port B end only◆

27 = "2" and "7" combined◆

28 = "2" and "8" combined■

Omit if not required

▼ Not applicable to DG5*-H8-B(L) models.

◆ Not applicable to models shown in the "DG5*-H8-BL spring offset, end-to-center, opposite hand" section three pages back.

■ Not applicable to models shown in the "DG5*-H8-B spring offset, end-to-center" section three pages back.

6 External pilot supply

Omit for internal pilot supply

7 Internal pilot drain

Omit for external drain, which is also mandatory for 1, 4, 8 and 9 spool-type valves

8 Minimum-pilot-pressure generator ("P" port option)

K = 0,35 bar (5 psi) cracking pressure

S = 5,2 bar (75 psi) cracking pressure

Omit if not required

9 Manual override option

Blank = Plain override in solenoid end(s) only▼

H = Water-resistant manual override on solenoid end(s)▼

Z = No override at either end

▼ No override in non-solenoid end of single-solenoid valves.

10 Solenoid energization identity

V = Solenoid "A" is at port A end of pilot valve and/or solenoid "B" at port B end independent of main-stage valve port locations or spool type; German practice.

Omit (except as noted below) for US ANSI B93.9 standard whereby solenoid "A" is that which when energized connects P to A in main-stage valve, and/or solenoid "B" connects P to B.

Note: Energization identities on valves with type 4 or 8 spools are identical under US and German practices. In such cases the "V" code is used.

11 Solenoid type/connection(s)

- U = ISO 4400 (DIN 43650) mounting■
FW = 1/2" NPT thread junction box
FTW = 1/2" NPT thread junction box and terminal strip
FJ = M20 thread junction box
FTJ = M20 thread junction box and terminal strip
FPA3W= Junction box with 3-pin male connector▲ to NFPA T3.5.29-1980 for single-solenoid valves
FPA5W= Junction box with 5-pin male connector▲ to NFPA T3.5.29-1980 for single or double-solenoid valves

- Some female plug connector options available separately from Vickers Systems (see "Plugs to ISO 4400" eleven pages on). Others available from electrical stockists.
▲ Female connector to be supplied by user.

12 Indicator lights, option for codes FTJ, FTW, FPA3W and FPA5W in 11

- L = Lights fitted
Omit if lights not required
For U-code solenoids use plug with integral light, see eleven pages on.

13 Coil rating

- See "Operating Data" for further information.
A = 110V AC 50 Hz
B◆ = 110V AC 50 Hz/120V AC 60 Hz
C = 220V AC 50 Hz
D◆ = 220V AC 50 Hz/240V AC 60 Hz
G = 12V DC
H = 24V DC
◆ For 60 Hz or dual frequency.

14 Design number

- 10 series for DG3/17V valves
30 series for DG3/17S valves
30 series for DG5V valves
50 series for DG5S valves
Subject to change. Installation dimensions unaltered for design numbers *0 to *9 inclusive.

Supporting Products

See under that heading three pages on.

Operating Data

Performance data typical under standard test conditions which use antiwear hydraulic oil (Class L-HM) at 21 cSt (105 SUS) and 50°C (122°F).

| | | | |
|--|--|---|---------------------------|
| Maximum pressures | | See "Maximum operating pressures" table two pages on | |
| Maximum flow rates, in L/min (USgpm) at the minimum pilot pressures (see "Pilot Pressures" three pages on) | | | |
| Model | Spool type | Max. flow rate, L/min (USgpm) at: | |
| | | 210 bar (3000 psi) | 350 bar (5000 psi) |
| DG3*-H8-*A(L) | 0, 2, 6, 9, 52 & 521 X2 & Y2 | 500 (132) 300 (80) | 500 (132) 300 (80) |
| | 0 | 700 (185) | 650 (172) |
| | 1 | 650 (172) | 500 (132) |
| DG5*-H8-A(L) | 2▲ & 3 | 700 (185) | 700 (185) |
| DG3*-H8-*C | 4 | 350 (92) | 220 (58) |
| DG5*-H8-*B(L) | 6 | 650 (172) | 600 (160) |
| DG5*-H8-*C | 8 | 700 (185) | 450 (120) |
| DG5*-H8-*N | 9 | 350 (92) | 220 (58) |
| | 11 | 650 (172) | 500 (132) |
| | 31, 33▲, 34, 52 & 521 X2, X33, Y2 & Y33 | 700 (185) 300 (80) | 700 (185) 300 (80) |
| | 0, 1, 2▲ & 3 | 700 (185) | 700 (185) |
| DG3*-H8-*D | 4 | 350 (92) | 220 (58) |
| DG5*-H8-*D | 6 | 650 (172) | 600 (160) |
| | 8 | 650 (172) | 350 (92) |
| | 9 | 400 (106) | 300 (80) |
| | 11, 31, 33▲, 52 & 521 X2, X33, Y2 & Y33 | 700 (185) 300 (80) | 700 (185) 300 (80) |
| DG17*-H8-A(L) | 0, 2 & 6 | 530 (140) | 530 (140) |
| DG17*-H8-*N | | | |
| DG17*-H8-*C | 0, 2, 6, 8 & 33 | 530 (140) | 530 (140) |
| | 4 | 350 (92) | 220 (58) |
| ▲ Higher flow rates possible at higher pilot pressures; consult your local Vickers sales engineer. | | | |
| Minimum pilot pressures, DG3/5* valves | | See under that heading three pages on | |
| Control (swept) volume(s), DG3* and main-stage of DG5* valves: | | | |
| Center-to-end | | 11,6 cm ³ (0.70 in ³) | |
| End-to-end | | 23,2 cm ³ (1.42 in ³) | |
| Hand movement, DG17* valves: | | | |
| DG17*-H8-*A(L)/*N models | | 196 mm (7.72 in) nominal | |
| DG17*-H8-*C models | | 98 mm (3.86 in) nominal | |
| Operating force by hand, DG17* valves, at 280 bar and under standard test conditions: | | | |
| DG17*-H8-*A(L) models | | 190N at 265 L/min (70 USgpm) 240N at 530 L/min (14 USgpm) | |
| DG17*-H8-*C models | | 120N at 265 L/min (70 USgpm) 180N at 530 L/min (140 USgpm) | |
| DG17*-H8-*N models | | 60N at 265 L/min (70 USgpm) 125N at 530 L/min (140 USgpm) | |
| Voltage ratings, DG5* valves | | See 13 in "Model Code" on previous page | |

Continued on next page

| Voltage limits, DG5V valves: Maximum voltage Minimum voltage | See "Temperature limits" below. 90% of rated voltage | | | | | | | | |
|--|---|----------------|----------------|-----|----|-----|----|-----|----|
| Power consumption, DG5* valves with AC solenoids: Single-frequency coils, 50 Hz types "A" and "C" Dual-frequency coils at 50 Hz, types "B" and "D" Dual-frequency coils at 60 Hz, types "B" and "D" | <table> <thead> <tr> <th>Initial VA rms</th> <th>Holding VA rms</th> </tr> </thead> <tbody> <tr> <td>225</td> <td>39</td> </tr> <tr> <td>265</td> <td>49</td> </tr> <tr> <td>260</td> <td>48</td> </tr> </tbody> </table> | Initial VA rms | Holding VA rms | 225 | 39 | 265 | 49 | 260 | 48 |
| Initial VA rms | Holding VA rms | | | | | | | | |
| 225 | 39 | | | | | | | | |
| 265 | 49 | | | | | | | | |
| 260 | 48 | | | | | | | | |
| Power consumption, DG5* valves with DC solenoids | 30W at rated voltage and 20°C | | | | | | | | |
| Relative duty factor, DG5* valves | Continuous; ED = 100% | | | | | | | | |
| Type of protection, DG5* valves: ISO 4400 coils with plug fitted correctly Junction box Coil winding Lead wires (coil types "F****") Coil encapsulation | IEC 144 class IP65 IEC 144 class IP65 (NEMA 4) Class H Class H Class F | | | | | | | | |
| Pressure drop characteristics, including metering characteristics of X* and Y* spools | See two pages on | | | | | | | | |
| Response times, DG3* and DG5* valves | See "Response Times" section three pages on | | | | | | | | |
| Temperature limits: Fluid temperature limits Ambient temperature limits: Minimum ambient, all valves Maximum ambients, DG5* valves with coils listed in 13 in "Model Code" two pages back, and under conditions stated below: Dual-frequency coils: at 50 Hz and 107% of rated voltage at 50 Hz and 110% of rated voltage at 60 Hz and 107% of rated voltage at 60 Hz and 110% of rated voltage Single-frequency (50 Hz) coils at 50 Hz and 110% of rated voltage DC coils at 110% of rated voltage | See four pages on. -20°C (-4°F) 65°C (150°F) 65°C (150°F) 65°C (150°F) 65°C (150°F) 65°C (150°F) 70°C (158°F) | | | | | | | | |
| Installation dimensions: Valves Mounting surface | Commence five pages on. See catalog 2425. | | | | | | | | |

Continued on next page

| | |
|---|--|
| <p>Mass (weight), basic models:</p> <p>DG3*-H8-*A/D</p> <p>DG3*-H8-*C</p> <p>DG5*-H8-*A/B (AC voltages)</p> <p>DG5*-H8-*A/B (DC voltages)</p> <p>DG5*-H8-*C/N (AC voltages)</p> <p>DG5*-H8-*C/N (DC voltages)</p> <p>DG5*-H8-*D (AC voltages)</p> <p>DG5*-H8-*D (DC voltages)</p> <p>DG17*-H8-*A</p> <p>DG17*-H8-*C/N</p> | <p>kg (lb)approx.</p> <p>17,0 (37.4)◆</p> <p>16,4 (36)◆</p> <p>17,6 (38.7)◆</p> <p>17,8 (39.1)◆</p> <p>18,0 (39.6)◆</p> <p>18,5 (40.7)◆</p> <p>18,6 (40.9)◆</p> <p>19,1 (42.0)◆</p> <p>20,7 (45.5)</p> <p>20,1 (44.2)</p> <p>◆ Add 1,1 kg (2.4 lb) when pilot choke adjustment is fitted.</p> |
| <p>Supporting products:</p> <p>Subplate</p> <p>Fastener kit</p> | <p>See catalog 2425.</p> <p>See catalog 2314 and select appropriate M12 or 1/2"-13UNC 6-bolt kit from length options.</p> |
| <p>Installation and commissioning:</p> <p>Mounting attitudes, DG3* series</p> <p>Mounting attitudes, DG5* series</p> <p>Mounting attitudes, DG17* series</p> | <p>Optional for models shown.</p> <p>Optional for DG5*-H8-*B(L)/C/D models, but horizontal mounting is recommended for DG5*-H8-*A(L)/N models▼.</p> <p>Optional for DG17*-H8-*A(L)/C, but horizontal mounting is recommended for DG17*-H8-*N models▼.</p> <p>▼ DG5/17*-H8-*A(L)/N models may be adversely affected by excessive shock, vibration and/or unusual pressure transients.</p> |
| <p>After-sales service:</p> <p>Spare-parts data for DG3/17 and main-stages of DG5 valves, and pilot choke modules</p> <p>Spare-parts data for DG4V-3S pilot stages of DG5 valves</p> | <p>Consult your local Vickers representative.</p> <p>Ask for spares catalog I-3886-S (minimal text, in English).</p> |

Maximum Operating Pressures

| Model | Ports | Max. pressure, bar | | | |
|---|--------------------------|--------------------------|---------------------|--------------------------|-----------------------|
| | | DG*S models 30-series | 50-series ● | DG*V models 10-series | 30-series ● |
| DG3*-H8 ▲ | P, A, B, T, X & Y L | 210 0,5 | – – | 350 0,5 | – |
| DG5*-H8-**(L)(-**)(-E)(-*) (externally drained) | P, A, B, T & X Y L | – – – | 210 100 ● 0,5 | – – – | 350 ● 100 ● 0,5 |
| DG5*-H8-**(L)(-**)(-E)-T(-*) (internally drained)▲ | P, A, B & X T | – – | 210 100 ● | – – | 350 ● 100 ● |
| DG17*-H8 | P, A, B & T Y | 210 2 | – – | 350 2 | – – |

▲ Internal drain option available for all except pressure centered versions

● **Important:** DG5S, 50 series and DG5V, 30 series two-stage valves have been designed to satisfy the needs of most applications. Consult your Vickers representative about an alternative model if:

- Valves are required to remain pressurized for long periods without frequent switching, and/or
- Back pressure on the drain port of externally drained models (or the tank port of internally drained models) is required to rise above 100 bar.

Minimum Pilot Pressures, DG3* and DG5* Valves

Typical values:

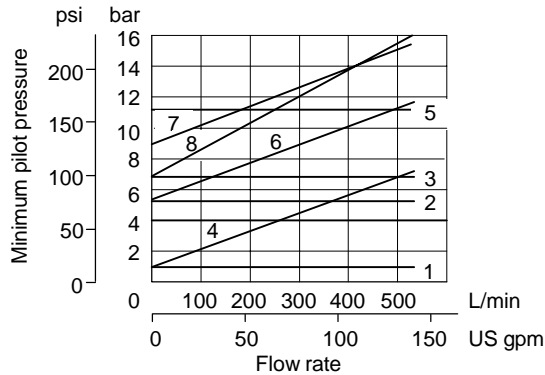

| Model | Spool | Curve |
|---------------|--|-------|
| DG3*-H8-*A(L) | 0, 9 | 5 |
| | 2, 6, 52, 521, X2, Y2 | 7 |
| DG3*-H8-*C | 0, 1, 4, 8, 9, 11 | 2 |
| DG5*-H8-*C | 2, 3, 6, 31, 33, 34, 52, 521, X2, Y2, X33, Y33 | 6 |
| DG3*-H8-*D | 0, 1, 4, 8, 9, 11 | 3 |
| DG5*-H8-*D | 2, 3, 6, 31, 33, 34, 52, 521, X2, Y2, X33, Y33 | 8 |
| DG5*-H8-*A(L) | 0, 9 | 1 |
| | 2, 6, 52, 521, X2, Y2 | 4 |
| DG5*-H8-*B(L) | 0, 4, 8 | 2 |
| | 2, 521, X2, Y2 | 6 |
| DG5*-H8-*N | 0, 9 | 2 |
| | 2, 6, 52, 521, X2, Y2 | 6 |

Pressure Drop Characteristics

Typical under standard test conditions, i.e. with oil at 21 cSt (105 SUS) and of 0.865 specific gravity. For other viscosities the pressure drops shown below will change approximately as follows:

Other viscosities (cSt)

| | | | | | | |
|-------------------------------------|-----|-----|-----|-----|-----|-----|
| 14 | 32 | 43 | 54 | 65 | 76 | 86 |
| % of pressure drop from above table | | | | | | |
| 93 | 111 | 119 | 126 | 132 | 137 | 141 |

A change to another specific gravity will yield an approximately proportional change in pressure drop.

The specific gravity of a fluid may be obtained from its producer. Fire-resistant fluids usually have higher specific gravities than oil.

All Spools at Full Stroke and Centered Positions

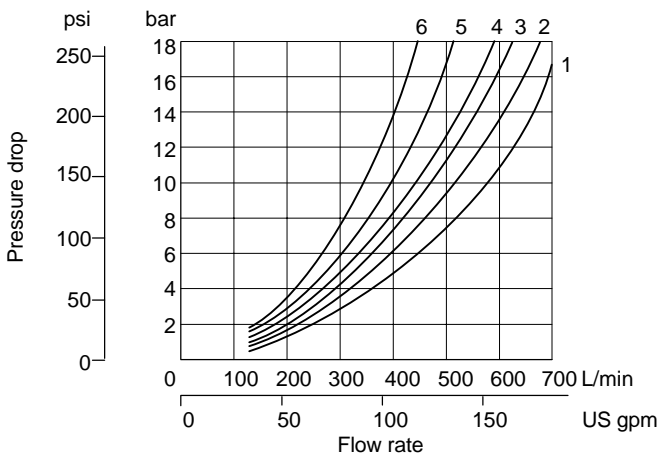

| Spool type | Flow-direction curve ref. | | | | |
|------------|---------------------------|-------|-------|-------|-------|
| | P → A | B → T | P → B | A → T | P → T |
| 0 | 2 | 5 | 2 | 3 | 4■ |
| 1 | 1 | 2 | 2 | 2 | 5▼ |
| 2 | 1 | 2 | 1 | 2 | – |
| 3 | 1 | 2 | 1 | 4 | – |
| 4 | 1 | 4 | 1 | 3 | 6 |
| 6 | 1 | 4 | 1 | 4 | – |
| 8 | 1 | 4 | 1 | 3 | 6 |
| 9 | 2 | 4 | 2 | 3 | – |
| 11 | 2 | 2 | 1 | 2 | 5 |
| 31 | 1 | 4 | 1 | 2 | – |
| 33 | 1 | 2 | 1 | 1 | – |
| 52▲ | 2■ | – | 5▼ | – | – |
| 52● | – | – | 5 | 2 | – |
| X2◆, X33◆ | ★ | 2 | ★ | 1 | – |
| Y2◆, Y33◆ | 1 | ★ | 1 | ★ | – |

- ▲ Selected P → A.
- Selected P → B.
- Ports A and B plugged.
- ▼ Port A plugged.
- Port B plugged.
- ◆ Before using at flow rates above 265 L/min (70 USgpm) consult your local Vickers sales engineer.
- ★ See the two graphs on next page.

Note: Consult your local Vickers sales engineer regarding pressure drops in the regenerative position of type "52" spool and in all positions of type "521" spool, not listed here.

Minimum-Pilot-Pressure Generator Options (“P” port)

Additive to “Pressure Drop Characteristics” graph on previous page.

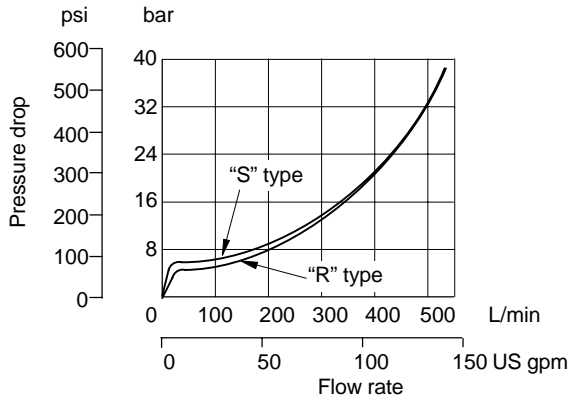

Metering Characteristics of X2, X33, Y2 and Y33 Spools Used with Stroke Adjusters

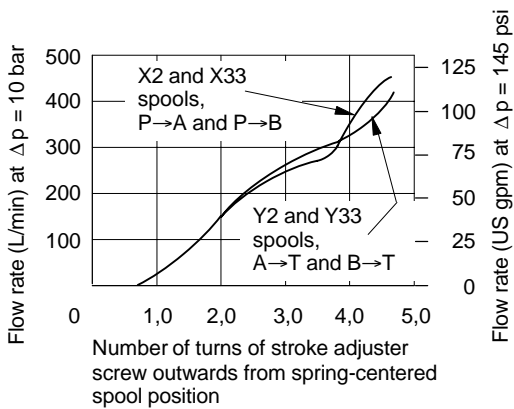

Response Times, DG3* and DG5* Valves

Taken from when the signal is first applied at the valve until the main-stage spool completes its travel. Signals are electric for DG5 models or hydraulic for DG3 models.

All are typical under standard test conditions.

| Model | Signal | Response time (ms) at stated pilot pressure | | | | |
|---------------|-----------|---|---------------------|-----------------------|-----------------------|-----------------------|
| | | 13 bar (190 psi) | 50 bar (725 psi) | 100 bar (1450 psi) | 210 bar (3000 psi) | 350 bar (5000 psi) |
| DG3*-H8-2A(L) | Select | – | 100 | 65 | 50 | 50 |
| | Return | – | 105 | 105 | 105 | 105 |
| DG5*-H8-2D | Select AC | 185 | 65 | 50 | 40 | 35 |
| | Return AC | 110 | 60 | 50 | 40 | 40 |
| DG5*-H8-2C | Select AC | 120 | 60 | 45 | 40 | 35 |
| | Select DC | 145 | 85 | 70 | 60 | 45 |
| | Return AC | 85 | 85 | 85 | 85 | 85 |
| | Return DC | 90 | 90 | 90 | 90 | 90 |

Note: Response times are dependent on adequate pilot flow. For control (swept) volumes see four pages back

Hydraulic Fluids

Materials and seals used in these valves are compatible with antiwear hydraulic oils, water-glycols, water-in-oil emulsions and non-alkyl-based phosphate esters. The extreme operating range is 500 to 13 cSt (2270 to 70 SUS) but the recommended running range is 54 to 13 cSt (245 to 70 SUS). For further technical information about fluids see leaflet B-920 or I-286S.

Contamination Control Requirements

Recommendations on contamination control methods and the selection of products to control fluid condition are included in Vickers publication 9132 or 561, "Vickers Guide to Systemic Contamination Control". The book also includes information on the Vickers concept of "ProActive Maintenance". The following recommendations are based on ISO cleanliness levels at 2 µm, 5 µm and 15 µm. For products in this catalog the recommended levels are:

Up to 210 bar (3000 psi) 20/18/15
Above 210 bar (3000 psi) 19/17/14

Fluid Temperatures

For petroleum oil:

Min. -20°C (-4°F)
Max.* +70°C (+158°F)

* *To obtain optimum service life from both fluid and hydraulic system, 65°C (150°F) normally is the maximum temperature.*

For other fluids where limits are outside those of petroleum oil, consult fluid manufacturer or Vickers representative. Whatever the actual temperature range, ensure that viscosities stay within those specified under "Hydraulic Fluids".

Installation Dimensions in mm (inches)

Solenoid Controlled Models with ISO 4400 (DIN 43650) Electrical Connections and Pilot Choke

DG5*-H8-**(L)(-*)(-E)(-T)(-*)(-*)(-V)M-U example

3rd angle projection

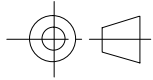

For stroke adjusters see next page.

For solenoid identification see two pages on.

For dimensions A, B, C, D and E see two pages on.

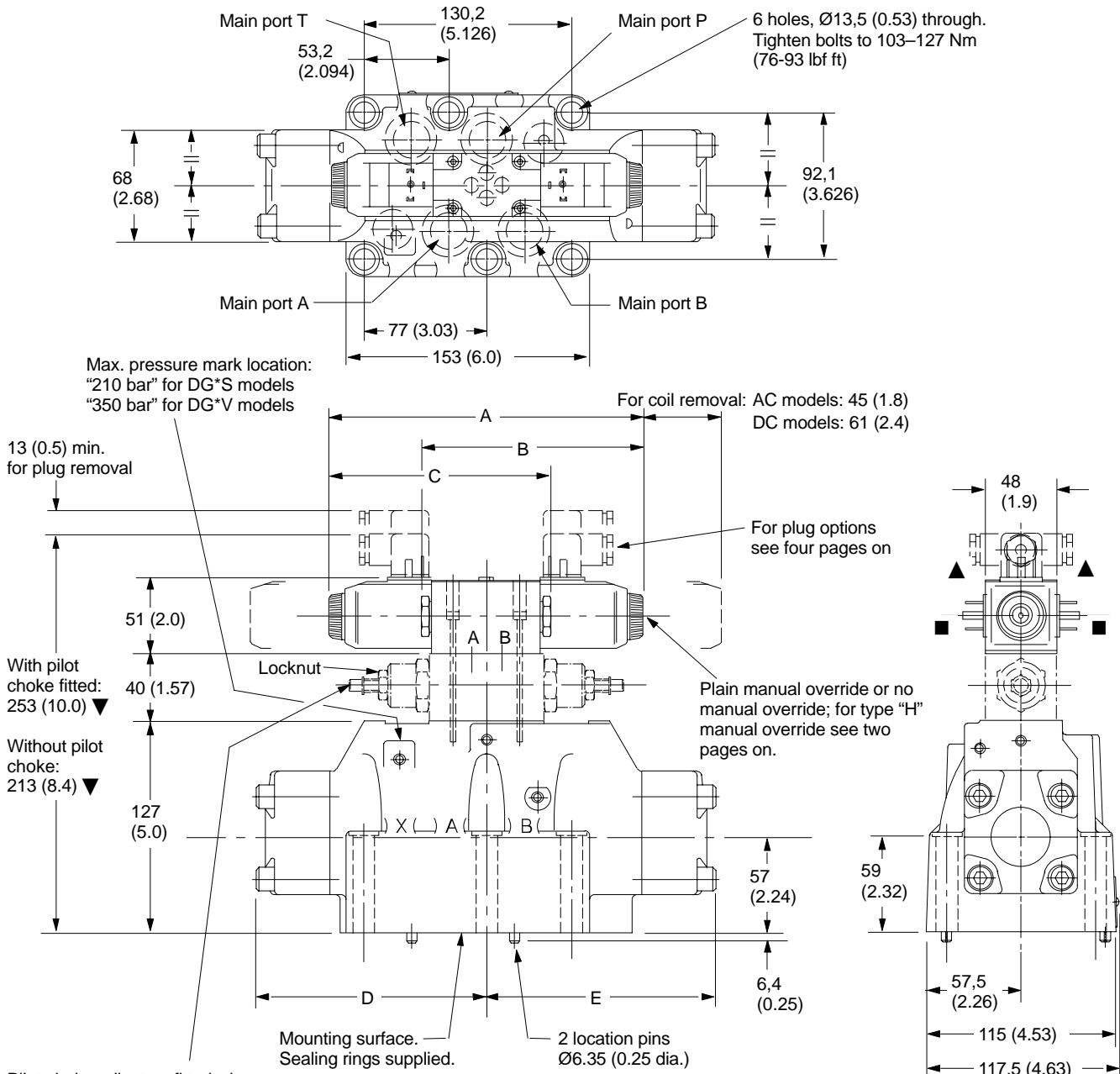

Pilot choke adjusters fitted when Model Code [5] = 2, 3, 27 or 28. To adjust, turn locknut counter-clockwise, then turn screw clockwise to slow down rate of spool travel, or counter-clockwise to increase the rate. Retighten locknut to 25-30 Nm (18-22 lbf ft).

- ▼ May vary according to plug source.
- Alternative plug positions by loosening knurled nut counter-clockwise, turning coil and retightening nut.

- ▲ Cable entry can be positioned at 90° either way from the position shown by reassembling the contact holder into the appropriate position inside the plug connector housing.

Solenoid Controlled Models with Stroke Adjusters

DG5*-H8-**(L)(-*)(-E)(-T)(-*)(-*)(-V)M-U example

For solenoid identification see next page.

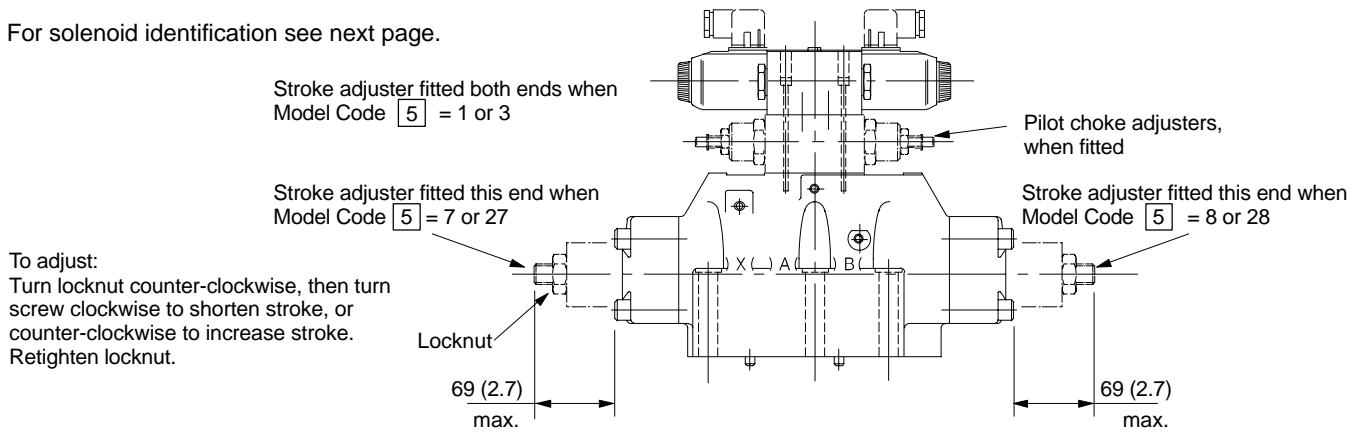

Solenoid Controlled Models with Junction Box having Optional Terminal Strip and Indicator Lights

DG5*-H8-**(L)(-*)(-E)(-T)(-*)(-*)(-V)M-F****(L) example

For solenoid identification see next page.

Available also with other options shown above and on previous page.

M20-6H x 1,5 thread for F(T)J options, or 1/2" NPT for F(T)W options at both ends. Closure plug fitted at one end.

For other options see [11] in "Model Code", eight pages back, and under "NFPA Connector---" and "Terminal Strip and Lights" sections, three pages on.

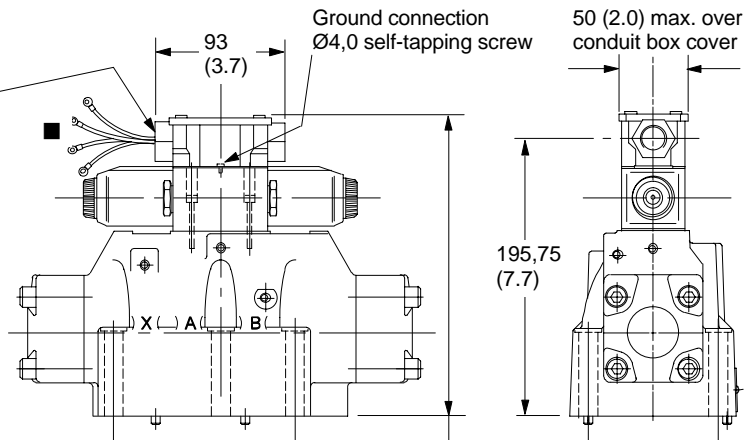

■ Ref. "Model Code" [11]:

Codes "FJ" and "FW":

2 lead wires for each solenoid, approx. 150 (6.0) long. M3 (#6) terminals provided for customer connection.

Codes "FTJ" and "FTW":

Valve supplied with lead wires connected into terminal strip suitable for M3 (#6) terminals provided for customer connection.

With pilot choke fitted: 258 (10.2)

Without pilot choke: 218 (8.6)

Pilot Operated Models with Optional Pilot Choke and/or Stroke Adjusters

DG3*-H8-**(L)(-*)(-E)(-T)(-*)(-*)(-V)M-F****(L) example

For dimensions D and E see next page.

Stroke adjuster fitted both ends when Model Code [5] = 1 or 3

Stroke adjuster fitted this end when Model Code [5] = 7 or 27

Pilot choke adjusters, when fitted

Stroke adjuster fitted this end when Model Code [5] = 8 or 28

With pilot choke fitted: 192 (7.6)

Without pilot choke: 152 (6.0)

69 (2.7) max.

D

E

69 (2.7) max.

Solenoid Identification

| Model (see also 10 in "Model Code" ten pages back) | Spool types | Solenoid identity at: | |
|--|--|-----------------------|-------------------|
| | | Main port "A" end | Main port "B" end |
| DG5*-H8-*A/B(-**)(-E)(-T)(-K)(-*)-M | All except "4" & "8" | – | B |
| DG5*-H8-*A/B(-**)(-E)(-T)(-K)(-*)-VM | All except "4" & "8" "4" & "8" only | – B | A – |
| DG5*-H8-*AL/BL(-**)(-E)(-T)(-K)(-*)-M | All except "4" & "8" | A | – |
| DG5*-H8-*AL/BL(-**)(-E)(-T)(-K)(-*)-VM | All except "4" & "8" "4" & "8" only | B – | – A |
| DG5*-H8-*C/D/N(-**)(-E)(-T)(-K)(-*)-M | All except "4" & "8" | A | B |
| DG5*-H8-*C/D/N(-**)(-E)(-T)(-K)(-*)-VM | All spools | B | A |

Dimensions

| Basic model designation | AC models | | | DC models | | | | |
|-------------------------|-----------|-----------|-----------|-----------|-----------|-----------|-----------|-----------|
| | A | B | C | A | B | C | D | E |
| DG3*-H8-*C | – | – | – | – | – | – | 135 (5.3) | 135 (5.3) |
| DG3*-H8-*A ■ | – | – | – | – | – | – | 135 (5.3) | 198 (7.8) |
| DG3*-H8-*A(L) ■ | – | – | – | – | – | – | 198 (7.8) | 135 (5.3) |
| DG3*-H8-*D | – | – | – | – | – | – | 198 (7.8) | 135 (5.3) |
| DG5*-H8-*A ■ | – | – | – | – | – | – | 135 (5.3) | 135 (5.3) |
| DG5*-H8-*B ■ | – | 147 (5.8) | – | – | 157 (6.2) | – | 135 (5.3) | 135 (5.3) |
| DG5*-H8-4/8BL | – | – | – | – | – | – | 135 (5.3) | 135 (5.3) |
| DG5*-H8-*AL ■ | – | – | – | – | – | – | 135 (5.3) | 135 (5.3) |
| DG5*-H8-*BL ■ | – | – | 147 (5.8) | – | – | 157 (6.2) | 135 (5.3) | 135 (5.3) |
| DG5*-H8-4/8B | – | – | – | – | – | – | 135 (5.3) | 135 (5.3) |
| DG5*-H8-*C | 200 (7.8) | – | – | 220 (8.7) | – | – | 135 (5.3) | 135 (5.3) |
| DG5*-H8-*N | 200 (7.8) | – | – | 220 (8.7) | – | – | 135 (5.3) | 135 (5.3) |
| DG5*-H8-*D | 200 (7.8) | – | – | 220 (8.7) | – | – | 198 (7.8) | 135 (5.3) |

■ Not types "4" or "8" spools.

Water-Resistant Manual Override on Solenoids

DG5*-H8-*(-**)(-E)(-T)(-*)H valves

Application:

General use where finger operation is required (standard manual overrides can only be operated by using a small tool).

Manual actuation must be applied within this diameter: approximately 20 (0.8). Spacer prevents actuation by larger device.

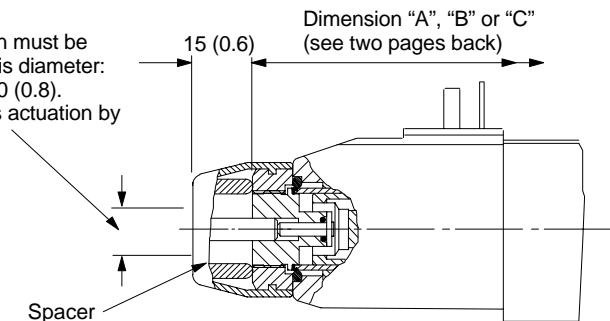

Note: "H" feature is not field convertible from other models; specify with order.

Hand-Lever Operated Models

DG17*-H8-*A illustrated.

DG17*-H8-*AL models differ by interchange of end caps, and of direction of flow between positions 1 and 3.

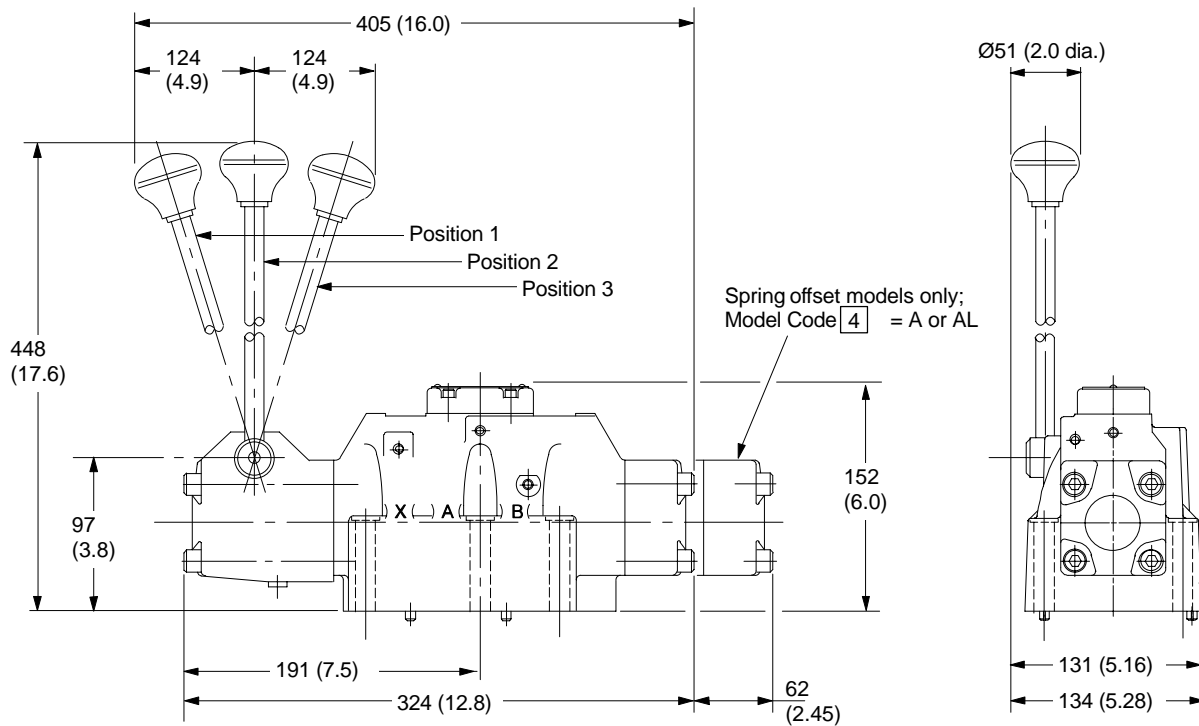

| Model | Flow direction at lever positions | | | | |
|--------------|-----------------------------------|-----------------|-----------------|--|---|
| | Two-position detented | Spring centered | Spring offset | Position 1 (Normal for DG17*-H8-*A models) | Position 2 Applies to: a. Spring centered or two-position detented models. b. Spring offset models at center crossover. |
| DG17*-H8-0N | DG17*-H8-0C | DG17*-H8-0A | P → B and A → T | P, A and B → T | P → A and B → T |
| DG17*-H8-2N | DG17*-H8-2C | DG17*-H8-2A | P → B and A → T | P, A and B blocked | P → A and B → T |
| DG17*-H8-4N | DG17*-H8-4C | - | P → A and B → T | P → T. A and B blocked | P → B and A → T |
| DG17*-H8-6N | DG17*-H8-6C | DG17*-H8-6A | P → B and A → T | P blocked. A and B → T | P → A and B → T |
| DG17*-H8-8N | DG17*-H8-8C | - | P → A and B → T | P → T. A and B blocked | P → B and A → T |
| DG17*-H8-33N | DG17*-H8-33C | - | P → B and A → T | P blocked. A and B → T | P → A and B → T |

Electrical Plugs and Connectors for DG5 Valves

Plugs for ISO 4400 (DIN 43650) Type Coil Connection

For valves with type "U" coils

The cable entry on these plugs can be repositioned at 90° intervals by reassembly of the contact holder relative to the plug housing.

The cable entry is Pg.11, for cable Ø 6-10 mm.

Order separately by part number.

Plugs without indicator lights

| Part no. | Color | Use on solenoid coil |
|----------|-------|----------------------|
| 710775 | Black | Sol. B |
| 710776 | Gray | Sol. A |

Plugs with indicator lights

| Voltage | Part no. | |
|----------|---------------|----------------|
| | Gray (sol. A) | Black (sol. B) |
| 12- 24V | 977467 | 977466 |
| 100-125V | 977469 | 977468 |
| 200-240V | 977471 | 977470 |

NFPA Connector T3.5.29-1980

DG5*-H8-**(**)---FPA3W(L) and DG5*-H8-**(**)---FPA5W(L) models

The receptacle is a standard three or five-pole connector with shortened leads and terminals added. The five-pole plug has four leads 101,6 mm long and one of 177,8 mm length. All wires have US Underwriters Laboratory-recognized non-solder insulated eyelet terminals. The green wire is used for the ground (earth) connection (No. 8-size screw furnished). Valves are supplied prewired.

Connection details and model type/model code references

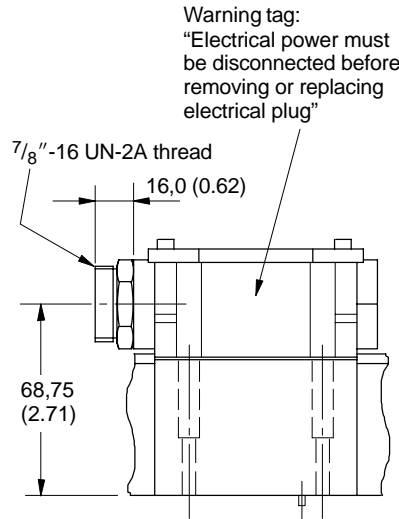

5-pin connector

When fitted in double-solenoid valves, e.g.:

DG5*-H8-*C---FPA5W(L)

DG5*-H8-*D---FPA5W(L)

DG5*-H8-*N---FPA5W(L)

1-lead (to solenoid "B")

5-lead (to solenoid "B")

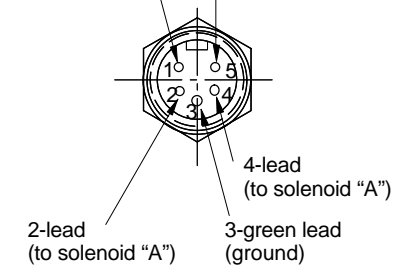

3-pin connector

When fitted in single-solenoid valves, e.g.:

DG5*-H8-*A(L)---FPA3W(L)

DG5*-H8-*B(L)---FPA3W(L)

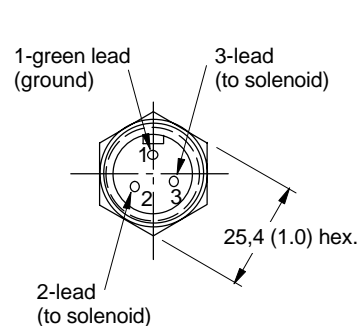

5-pin connector

When fitted in single-solenoid valves, e.g.:

DG5*-H8-*A(L)---FPA5W(L)

DG5*-H8-*B(L)---FPA5W(L)

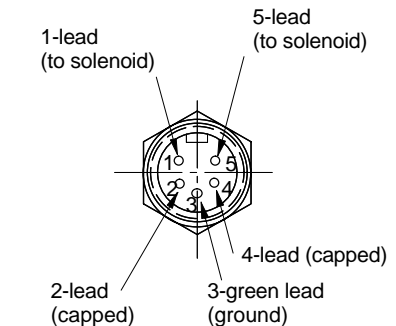

Terminal Strip and Light Options

When fitted in solenoid controlled valves DG5*-H8-**(L)---F****(L).

DG5*-H8-**(L)---F****-*

DG5*-H8-**(L)---F****L-*

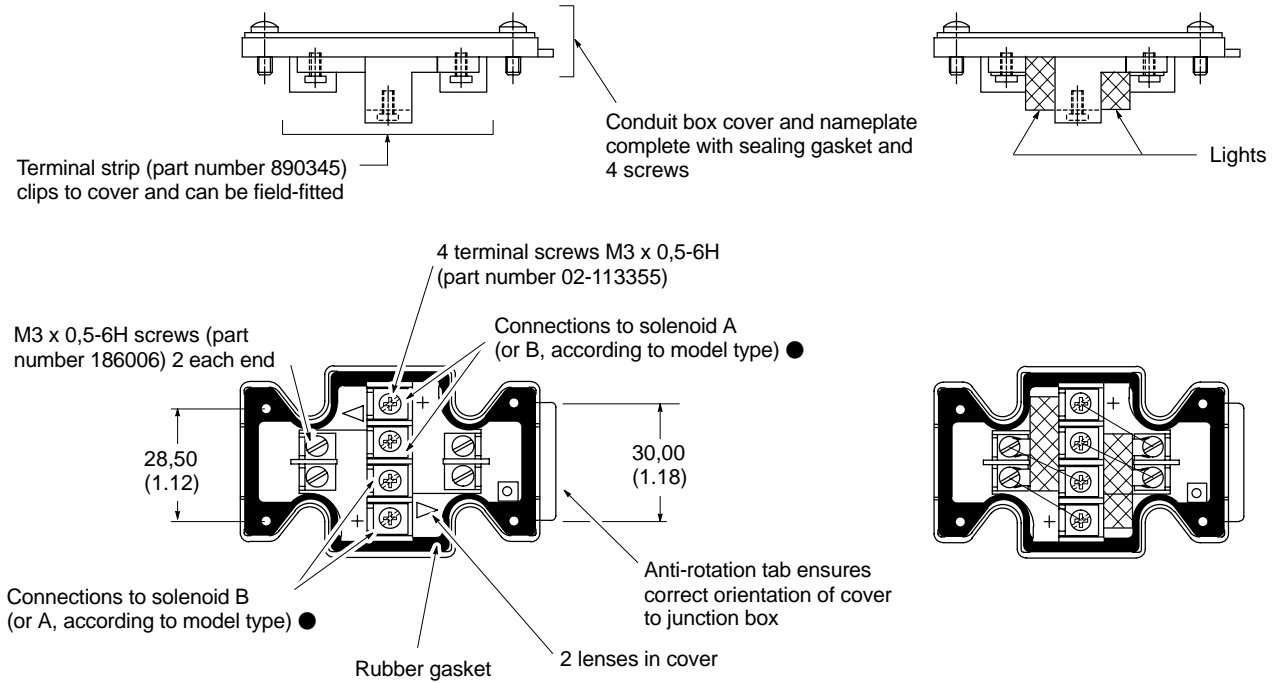

- 1. For DC coils the +ve lead(s) must be connected to the terminal(s) marked +. When using 3-wire incoming leads to double solenoid valves (i.e. common neutral) the inner pair of terminals must be linked.
- 2. For correct light indication of energized solenoid ensure that solenoid leads are correctly connected: light terminals are common with each outer pair of solenoid terminals according to the side with + mark.