

## High volume rotary vane pumps



The high volume rotary vane pumps are sold worldwide under the trademark Rotoflow. They are available in six flow ratings to meet the needs of high volume pumping.

### Technical features and manufacturing characteristics

The rotary vane pump with brass or stainless steel body utilizes a stainless steel AISI 303 rotor, while the pumping chamber and the vanes are in graphitic carbon.

Inlet and outlet ports are 1/2" NPT female threaded and the pump is equipped with a built-in adjustable bypass valve. The pump can be connected directly coupled to a motor with a metallic clamp or to M71 and M80 unel mec frame motors with the appropriate coupling and adapter set.

All models, upon request, are available:

- with special clearances (suffix-H) for temperature higher than 70 C (158 F) max 90 C (194 F)
- with Viton/EPDM seals (suffix-E) for special fluids
- NSF listed pumps for potable water  
In this case the prefix for each model is PA instead of PO.

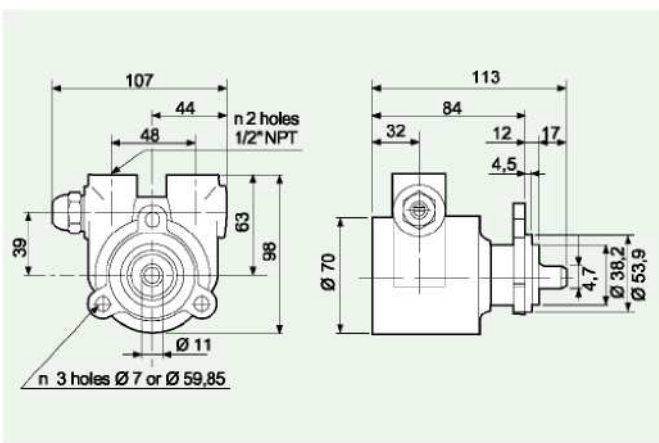
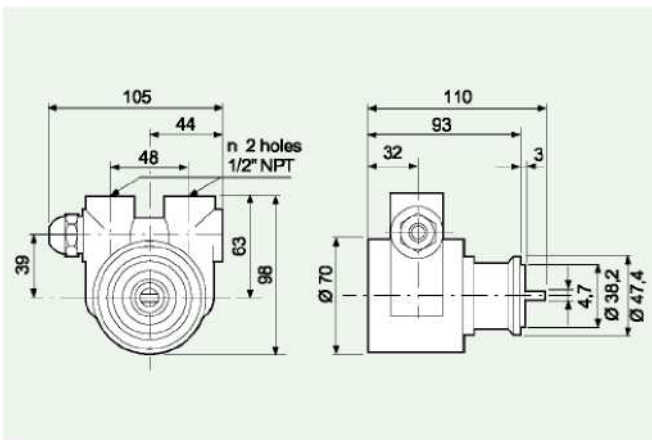

### Main applications

- Post-mix drink dispensers
- Cooling and booster systems
- Fuel injection systems
- Reverse osmosis
- Ultra-filtration

# High volume rotary vane pumps

MODEL PO/PA Brass	500	501	500F	501F	600	601	600F	601F	700	701	700F	701F	800	801	800F	801F	900	901	900F	901F	1000	1001	1000F	1001F
MODEL PO/PA Stainless steel	510	511	510F	511F	610	611	610F	611F	710	711	710F	711F	810	811	810F	811F	910	911	910F	911F	1010	1011	1010F	1011F
l/h at 2 bar			540				640				740				840				940					1040
l/h at 7 bar			520				620				720				820				920					1020
l/h at 14 bar			497				597				697				797				897					997
Figure			L-L				M-M				N-N				P-P				R-R					S-S
By-Pass valve	NO	YES	NO	YES	NO	YES	NO	YES	NO	YES	NO	YES	NO	YES	NO	YES	NO	YES	NO	YES	NO	YES	NO	YES
Flange mount	NO	NO	YES	YES	NO	NO	YES	YES	NO	NO	YES	YES	NO	NO	YES	YES	NO	NO	YES	YES	NO	NO	YES	YES
Clamp mount	YES	YES	NO	NO	YES	YES	NO	NO	YES	YES	NO	NO	YES	YES	NO	NO	YES	YES	NO	NO	YES	YES	NO	NO

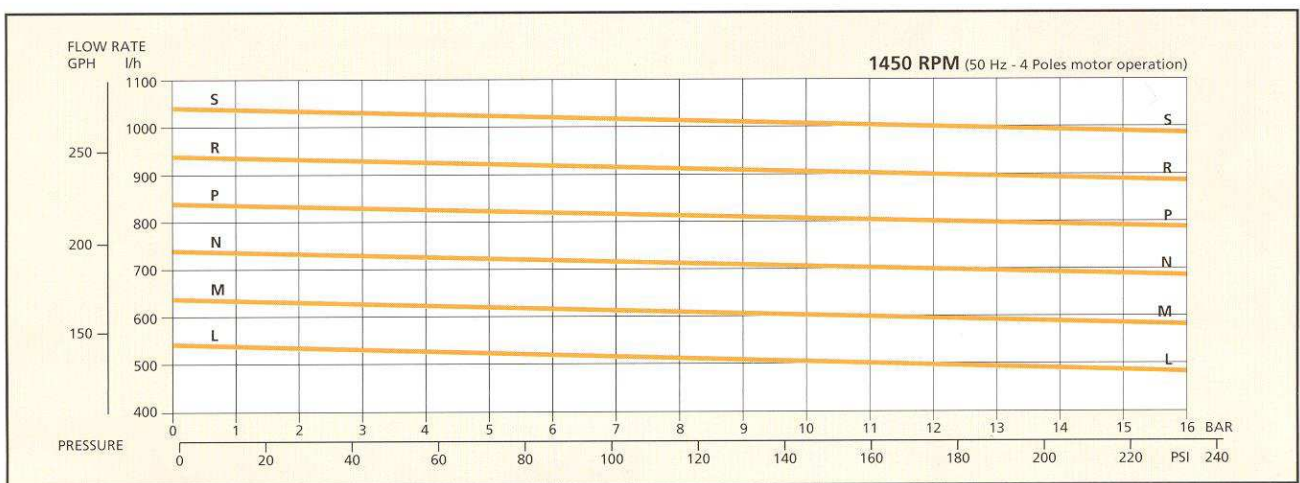

MODEL PO/PA Brass	500	501	500F	501F	600	601	600F	601F	700	701	700F	701F	800	801	800F	801F	900	901	900F	901F	1000	1001	1000F	1001F
MODEL PO/PA Stainless steel	510	511	510F	511F	610	611	610F	611F	710	711	710F	711F	810	811	810F	811F	910	911	910F	911F	1010	1011	1010F	1011F
GPH at 20 psi			170				201				232				264				295					327
GPH at 100 psi			165				196				227				259				290					322
GPH at 200 psi			159				190				221				253				284					316
Figure			L'-L'				M'-M'				N'-N'				P'-P'				R'-R'					S'-S'
By-Pass valve	NO	YES	NO	YES	NO	YES	NO	YES	NO	YES	NO	YES	NO	YES	NO	YES	NO	YES	NO	YES	NO	YES	NO	YES
Flange mount	NO	NO	YES	YES	NO	NO	YES	YES	NO	NO	YES	YES	NO	NO	YES	YES	NO	NO	YES	YES	NO	NO	YES	YES
Clamp mount	YES	YES	NO	NO	YES	YES	NO	NO	YES	YES	NO	NO	YES	YES	NO	NO	YES	YES	NO	NO	YES	YES	NO	NO

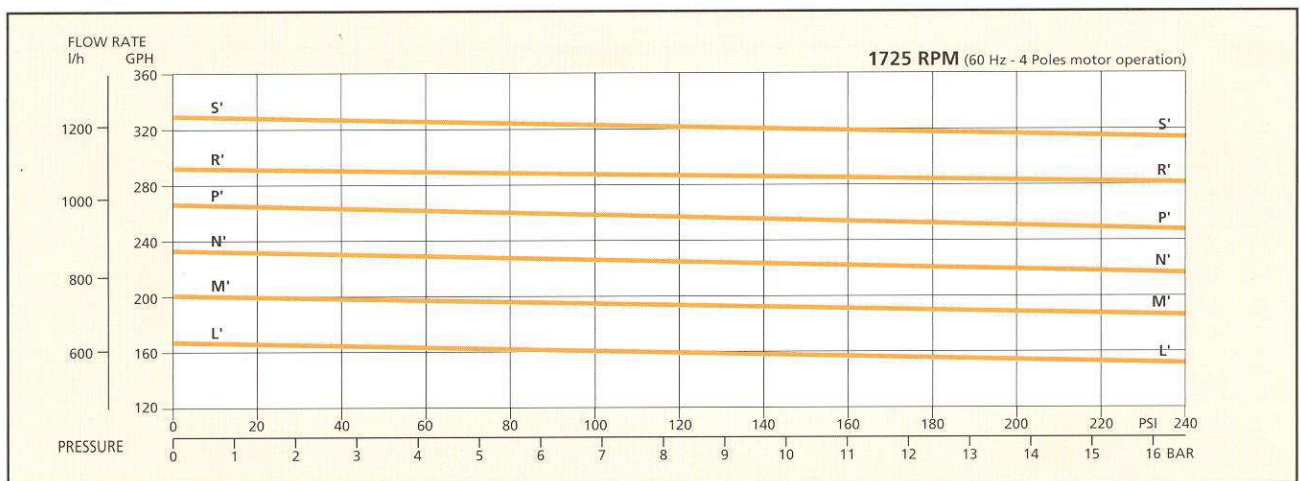

Characteristics at constant motor speed, with water at 68 °F and by-pass blocked - Figures of flow are averages - Pump weight: 1,9 kg (4,2 Lbs) clamp mount and 2 kg (4,4 Lbs) flange mount