

The HOKE Gyrolok Design

HOKE Gyrolok Tube Fittings have been carefully designed and manufactured to provide outstanding leak-tight integrity in a wide range of applications.

Materials

HOKE Gyrolok fittings are available in:

Brass:	BR
304 Stainless Steel:	304/304L
316 Stainless Steel:	316/316L
Monel:	M
Hastelloy® C-276:	HC
Duplex 2205:	DX3
Inconel:	600
Super Duplex 2507:	D50
Titanium:	TI
254 SMO:	6MO

316/316L SS Forgings:	ASTM A-182/SA182
304/304L SS Forgings:	ASTM A-182/SA182
Brass Bar Stock, Alloy 360:	ASTM B-16
316/316L SS Bar Stock:	ASTM A-479/SA479
304/304L SS Bar Stock:	ASTM A-479/SA479
Monel Forgings, Alloy 400:	QQ-N-281
Brass Forgings, Alloy 377: ASTM B-283	QQ-S-626
Monel Bar Stock, Alloy 405:	QQ-N-281
Brass Bar Stock, Alloy 353:	ASTM B-453

Contact your local HOKE distributor for further information.

Certified Material Text Reports (CMTRs)

Bodies and nuts of HOKE Gyrolok fittings in all materials other than Brass are heat code traceable. To obtain CMTRs for these components, place separate orders for such items and specify "CMTRs required on all items".

Pressure Rating

Hoke Gyrolok fitting ends are rated for working pressures higher than the tubing recommended for use with HOKE Gyrolok. Under no circumstances should tubing should be utilized at pressures above its maximum allowable working pressure. Refer to the HOKE Tubing Data Charts for specific information. If no pressure is identified for a given tube size and tube wall thickness, that tubing is not considered suitable for use with Gyrolok tube fittings. Pressure ratings may vary for the other fitting end if it is not Gyrolok (i.e. NPT or O-Ring Seal). For general working pressure ratings for NPT fittings ends, refer to the Hoke Pipe Fittings catalog. The user must determine whether both the Gyrolok side and the non-Gyrolok side working pressure ratings are suitable with the system pressure. For more information on Gyrolok pressure ratings, contact your local distributor, or HOKE directly.

PFA Coating

Stainless steel fittings larger than 1" and 25mm use stainless steel front ferrules with a PFA coating.

Vacuum Rating

HOKE Gyrolok offers deep vacuum capability. With good quality tubing, HOKE Gyrolok fittings will be leak-tight at vacuum levels of 10^{-9} torr while tested with a leakage sensitivity of 10^{-9} scc

Temperature

HOKE Gyrolok fittings provide safe, reliable performance from cryogenic temperatures to high temperature bake out levels, depending on material.

316 Stainless Steel:	-325° F to +800° F (-200° C to +426° C)*
----------------------	---

Stainless steel fittings larger than 1" and 25mm use front ferrules with a PFA coating. Applications above 450° F (232° C) require silver-plated front ferrules and uncoated rear ferrules. To order extended temperature fittings, add -HT to the basic part number.

Brass (copper tubing):	-325° F to +400° F (-200° C to +203° C)
Monel:	-325° F to +800° F (-200° C to +426° C)

* CAUTION: (for Stainless Steel):

Intermittent use to 1200° F (649° C) is possible, however prolonged exposure to temperatures over 800° F (426° C) is not recommended.

Identifying Metric Gyrolok Products

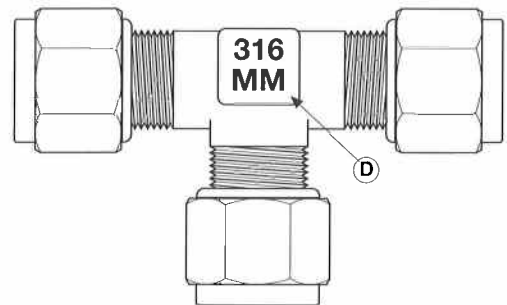
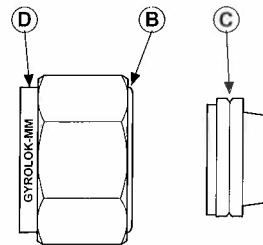
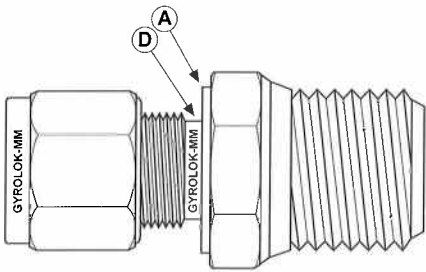

HOKE metric Gyrolok products have certain features which allow you to identify them from fractional products.

A. Step Machined on Body Hex

Straight bodies with a metric Gyrolok end have a step on the tube fitting side of the hex.

B. Short Shank on Nut

Metric nuts have a short shank on the threaded end.

C. Groove in Front Ferrule

Metric front ferrules of brass or 316 stainless steel have a groove in the shoulder. For other materials, see D.

D. MM Marking

The metric designation "MM" is stamped on:

- metric nuts and straight bodies—after the Gyrolok trademark
- metric elbows, tees and crosses—on the side opposite the HOKE logo
- front ferrules made from materials other than brass or 316 stainless steel—after material identification.

Color Coding

Blue boxes designate metric parts and accessories, including Safety Changer packaging and Gyrogages.

General Information

How to Order

The HOKE Gyrolok numbering system is a completely descriptive system that's easy to understand. Each part number describes completely assembled fittings.

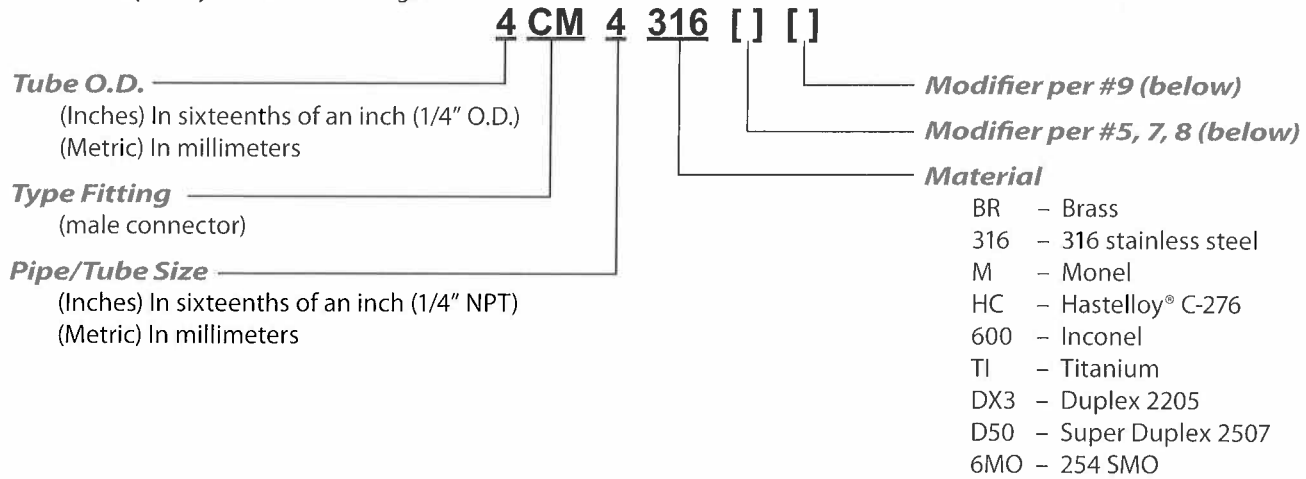

1. The first number (4) identifies the tube O.D. size. For example, 4 = 4/16" for fractional fittings. 4 = 4mm for metric fittings. If there is no 5th group, sizes are fractional.
2. The letter group, (CM) identifies the type of fitting (Male Connector). See fitting locator, pages 2 and 3.
3. The third group, a number (4), is only necessary if the second tube connection size is different from the first tube O.D. size. For pipe sizes, a number is always required.
4. Material is identified in the fourth group.
5. With the exception of branch tees, the fifth group, if present, contains two letter codes. The first letter designates the unit of measure for the first number in the part number—i.e, E for fractional, M for metric. The second letter indicates the unit of measure (E or M), or thread type, for the second number in the part number. If there is no 5th group, all sizes are fractional.

Examples:

4CM4 316 = 1/4 tube x 1/4 NPT male connector, 316 stainless steel

6RU3 BR ME = 6mm tube x 3/16 tube reducing union, brass

8LM4 316 EC = 1/2 tube x 1/4 male RT, male elbow, 316 stainless steel

Unit of measure/end connector codes:

- | | |
|---|---------------------------------|
| A = RS male ends | M = Metric tube, in millimeters |
| B = RP male ends | X = RS/RP female ends |
| C = RT ends | Z = RG female ends |
| E = fractional unit of measure in 1/16 th of an inch | |

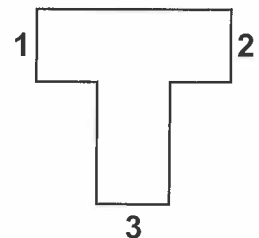

6. Tee part numbering: TEES are described by first the run (1 and 2) and next the branch (3), for example:
 - TTM describes a tee that has tube connections at 1 and 2 and a male pipe thread at position 3.
 - TFT describes a tee that has tube connections at 1 and 3 and a female pipe thread at position 2.
7. Fittings cleaned for oxygen service: To order, add HPS 18 to the end of basic fitting part number.
 Example: 4CM4 316 HPS 18
8. Fittings cleaned for nuclear service: To order, add HPS 90 to the end of basic fitting part number.
 Example: 4CM4 316 HPS 90
9. O-ring designator - Viton® (45) is standard for SAE fittings. In the event no material is specified, Viton will be supplied. Buna (21) is standard for other fittings with O-rings. Alternative O-ring materials are available, including silicone (01), and Buna-N (23). Example 6CMS631623

Thread Connections Available with Gyrolok Fittings

Pipe Thread Information

HOKE Gyrolok tube fittings are available with NPT (National Pipe Taper), BSP/ISO (British Standard Pipe/International Standards Organization), SAE or unified screw threads.

Tapered Threads

Specifications	Type	Part Number or Suffix Designation	Sealing Method
NPT	M/F	Fitting type ends in M or F, as in CM or CF	Seal is made on the thread. Thread sealant is required.
RT to ISO 7/1 • BS 21 • JIS B0203 • DIN 2999	M/F	Modifier is C, following the unit of measure for fractional (E) or metric (M), as in 6CM4316EC	Seal is made on the thread. Thread sealant is required. The BSP/ISO thread utilizes a different angle and the number of threads per inch may differ from NPT. Reference DIN 3852, Form C.
	M/F		
	M/F		
	Male		

FOR YOUR SAFETY

IT IS SOLELY THE RESPONSIBILITY OF THE SYSTEM DESIGNER AND USER TO SELECT PRODUCTS SUITABLE FOR THEIR SPECIFIC APPLICATION REQUIREMENTS AND TO ENSURE PROPER INSTALLATION, OPERATION AND MAINTENANCE OF THESE PRODUCTS. MATERIAL COMPATIBILITY, PRODUCT RATINGS AND APPLICATION DETAILS SHOULD BE CONSIDERED IN THE SELECTION. IMPROPER SELECTION OR USE OF PRODUCTS DESCRIBED HEREIN CAN CAUSE PERSONAL INJURY OR PROPERTY DAMAGE.

Straight and Parallel Threads

Specifications	Type	Part Number or Suffix Designation	Sealing Method
American Standard unified screw threads	Male	Fitting type ends in S, as in COS or AOS.	Generally utilizes an elastomer o-ring to provide sealing.
RP to ISO 228/1 • BS 2779 • JIS B0202	Male	Modifier is B, following the unit of measure for fractional (E) or metric (M), as in 6CM4316EB	Metal to metal sealing to DIN 3852, Form B.**
RS to ISO 228/1 • BS 2779 • JIS B0202	Male	Modifier is A, following the unit of measure for fractional (E) or metric (M), as in 6CM4316EA	Utilizes a sealing washer to provide sealing. Reference DIN 3852, Form A.**
RG to ISO 228/1 • BS 2779 • JIS B0202	Female	Modifier is Z, following the unit of measure for fraction (E) or metric (M), as in 6CF4316EZ	Sealing form meets DIN 16288, Form Z.

** Female RP or RS end available with Form X.

HOKE Gyrolok Fittings with SAE Ends

SAE Straight Thread O-Ring Seal Fittings

HOKE Gyrolok's SAE Straight Thread O-Ring Seal Fittings are designed and manufactured to SAE standards defined below for use in many different applications including hydraulics and natural gas vehicles. HOKE's SAE Straight Thread O-Ring Fittings are supplied with Viton O-rings.

Fittings available include: Tube to SAE straight connectors, positionable SAE elbows and tees, and SAE reducers.

SAE Specifications

HOKE's SAE Straight Thread O-Ring Seal Fittings are designed and manufactured to meet SAE Standards as follows:

- Male or External Fitting End Dimensions: SAE J514
- Straight Threads: SAE J475 (equivalent to ANSI B1.1 or ISO R725)
- Female or Internal Straight Thread Boss: SAE J1926 (see diagram below)

Thread and O-ring Sizes

Nominal Tube O.D.	Port Size	Thread Size	O-ring Size #
1/8	2	5/16 - 24	902
1/4	4	7/16 - 20	904
3/8	6	9/16 - 18	906
1/2	8	3/4 - 16	908
5/8	10	7/8 - 14	910
3/4	12	1 1/16 - 12	912
1	16	1 5/16 - 12	916

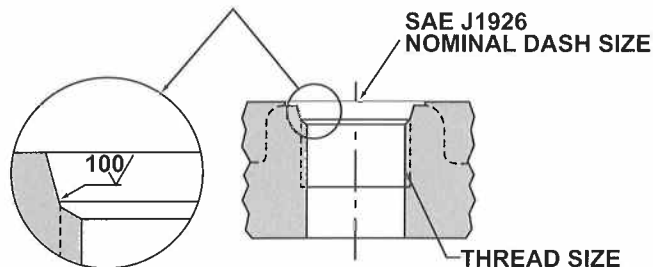

Installation Instructions

Positionable End Connections

1. Assure that the locknut is fully raised.
2. Turn the external SAE end clockwise into the internal boss until the metal washer is in contact with the boss.
3. Orient the Gyrolok end to the proper direction by now turning the fitting *counterclockwise* up to a *maximum* of 1 turn.
4. While supporting the body wrench pad with a backup wrench, tighten the locknut until the washer is snug against the face of the boss.

Gyrolok Assembly Instructions, see page 53.