

Dispensing valve **HPNV-50**

[High Pressure Needle Valve – Type 50]

Instruction Manual

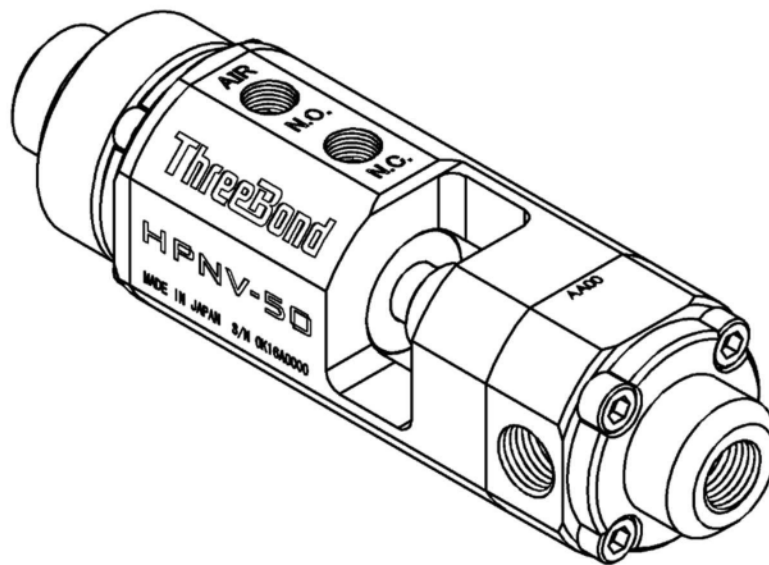

Ver. 1, October 1, 2016

Control Number: 166-A01E

Creating Our Future From a Single Drop

ThreeBond Co.,Ltd.

HPNV-50

Preface

Thank you for purchasing the ThreeBond Dispensing Valve.

This Instruction Manual describes information on handling procedures (i.e., operation and installation procedures) and maintenance necessary to ensure the safe use of this product. Be sure to read this Instruction Manual before using the product and also keep it on hand for immediate reference when needed to ensure the proper and safe use of the product.

Keep this manual in a safe place to be able to immediately read when needed.

[Important]

- Technical data provided in this Instruction Manual are just a few examples of theoretical values and measured values at our company, not guaranteed values.
- Be noted that we shall assume no responsibility whatsoever for the results of any operation other than that described in this Instruction Manual.
- Republication of the contents of this Instruction Manual without permission is prohibited.
- The contents of this Instruction Manual are subject to change at our own discretion without notice due to the improvement of this product.
- We are absolutely sure of the contents of this Instruction Manual. However, if there are any issues you have noticed including incorrect description and omission, please contact your ThreeBond representative.

HPNV-50

For Safety

We design and manufacture our product with utmost care and attention paid to the safety aspect. Using the product without following the safety rules may cause damage to the equipment and consequently lead to accidents resulting in injury or death.





To prevent such accidents, operators and maintenance personnel should surely observe the safety rules for operating the equipment.

Be sure to read and have a thorough understanding of the contents within this Instruction Manual, and further to observe the safety precautions marked with the pictograms listed below to perform the operation and maintenance of the equipment in accordance with the safety rules.

If the properties and the using procedure of product in which the HPNV-50 is to be used are unknown, NEVER attempt to use it.

We shall assume no responsibility for any injury and damage resulting from mishandling of the product.

Pictograms marked in this Instruction Manual

 DANGER	Indicates cases where non-observance of appropriate precautions induces an imminently hazardous situation that if not avoided, will result in death or serious injury of the user.
 WARNING	Indicates cases where non-observance of appropriate precautions induces a potentially hazardous situation that if not avoided, could result in death or serious injury of the user.
 CAUTION	Indicates cases where non-observance of appropriate precautions induces a potentially hazardous situation that if not avoided, may result in property damage.
 CHECK	Indicate matters and precautions to be observed for appropriate use of this product that if not avoided, may not result in damage.

The pictograms listed above are used in this Instruction Manual to indicate safety precautions to be observed for operating and working on the equipment.

Be sure to thoroughly read and observe these safety precautions for such purposes.

Safety precautions to be strictly observed

Personnel who have a thorough understanding of the equipment mechanism must perform the maintenance and check of this product.

Personnel who handle this product must thoroughly read this Instruction Manual and have a thorough knowledge of the contents thereof.

In order to perform maintenance of this product, be sure to turn off the supply source of compressed air.

CONTENTS

Preface	P 1
For Safety	P 2

1. Specifications

1.1 Overview	P 5
1.2 Specifications	P 5
1.3 Warranty scope and period	P 6
1.4 Storage	P 6

2. Installing

2.1 Installing procedure	P 7
2.1.1 Installing by use of positioning pins	P 7
2.1.2 Replacement of conventional valve	P 8

3. Connection

3.1 Air hose connection ports	P 9
3.2 Liquid hose connection ports	P10
3.3 Nozzle connection	P10

4. Operation

4.1 Valve operation and discharge operation	P11
4.2 Adjustment of stroke length	P11

5. Maintenance Check

5.1 Check items	P13
5.2 Overhaul	P14
5.3 Procedure for replacing material chamber	P15

6. Troubleshooting

6.1 Action to be taken in the event of trouble	P 16
6.2 Troubleshooting	P 16

7. Product Lineup

7.1 Standard product and spare parts	P 18
7.2 Optional parts	P 18
7.3 Dedicated nozzle and nozzle block	P 19

Revision History	P 20
-------------------------------	------

Appendix

- Outline View

HPNV-50

1. Specifications

1.1 Overview

- Pneumatically driven valve using a needle valve appropriate for high-pressure operation.
- Stroke adjustment mechanism allows adjustment of liquid flow control.
- Excellent durability facilitates replacement and maintenance of the material chamber.

1.2 Specifications

Model		HPNV-50	SVR <small>*Discontinued product</small>
Outside dimensions [W×D×H] <small>(*1)</small>		40mm×41.5mm×150mm	40mm×40mm×160mm
Weight		470 g	630 g
Drive source		Compressed air (clean dry air)	
Drive pressure		0.3 MPa to 0.6M Pa	
Drive system		Double-acting	
Adjustable range of stroke		0 mm to 4 mm (1 notch = 0.1 mm)	0 mm to 4 mm (arbitrarily adjustable)
Air connection size	N.O.	Rc 1/8	Rc 1/8
	N.C.	Rc 1/8	Rc 1/8
Liquid inlet size	IN	Rc 1/4	Rc 1/8
Liquid outlet size	OUT	Rp 1/4	Rp 1/4
Pressure resistance		20 MPa	16 MPa
Operating environment	Temperature	5°C to 40°C	
	Humidity	70%RH or less (no condensation)	
Suitable viscosity of liquid		Low to high viscosity	
Suitable liquid <small>(*2)</small>		TB1100 Series: Liquid gasket TB1200 Series: Silicon-based liquid gasket and potting agent TB2000 Series: Liquid epoxy compounded resin(base resin) TB2100 Series: Two-component epoxy compounded resin (curing agent) TB2200 Series: One-component epoxy compounded resin	

*1 Refer to the attached General View. (No drawing of SVR is attached.)

*2 The suitable liquid is just an example. Other liquid may be used. The suitability of the HPNV-50 for liquid varies with the usage and liquid feeder to be used in combination. For details, contact your ThreeBond representative.

The specification of the conventional product (SVR) is described above for the comparison of the specifications. Be noted that the production of the SVR has been discontinued.

1.3 Warranty scope and period

We warrant this product for a period of months as follows when it is normally used:

- Twelve (12) months from the date of delivery to the designated place (e.g. when this product is delivered to the designated place in May, we warrant it up to the end of May next year).

In the event of any of the following events, this warranty does not apply to this product:

- Damage resulting from inappropriate use;
- Adjustment and consumables made necessary due to wear resulting from proper handling;
- Damage and performance deterioration resulting from disassembly, modification, and alteration by any worker not authorized by us; and
- Matters not stated in the Instruction Manual and Specifications or directly provided by your ThreeBond Representative.

Action to be taken in the event of any abnormality

In the event of any abnormality in this product, contact your ThreeBond representative.

Others

Technical information, drawings, and other documents provided from us shall be treated as confidential.

Reproduction or transfer of the forgoing documents without our written permission is prohibited.

The warranty of this product shall not apply to the warranty of the quality and functions of the work piece coated using this product.

Cancellation

If you cancel an order placed with us, a cancellation fee may be incurred.

1.4 Storage

In order to store this product for a long period of time, pay careful attention to the following:

- Do not store the product in places with high humidity to prevent the formation of rust;
- Be sure to overhaul the product before storing it when liquid remains inside of it; and
- Refer to information in “5.2 Overhaul” on page 14 for overhauling.



CHECK

Storage environment

- Environmental temperature: 5 to 40°C
- Humidity: 70%RH or less (no condensation)
- Not exposed to direct sunlight
- Not stored in a dusty environment
- No oil mist and coolant sprayed on this product

HPNV-50

2. Installation

- Use two or four M6 bolts to mount the HPNV-50 valve (see **Fig. 1**).
- The holes for the bolts used to mount the valve are 8 mm in depth.

⚠ CAUTION To mount the valve, do not use bolts having a length in excess of the depth of the holes used to mount the valve.

Doing so may cause damage to the valve.

Note: A mounting bracket attaches the HPNV-50 valve.

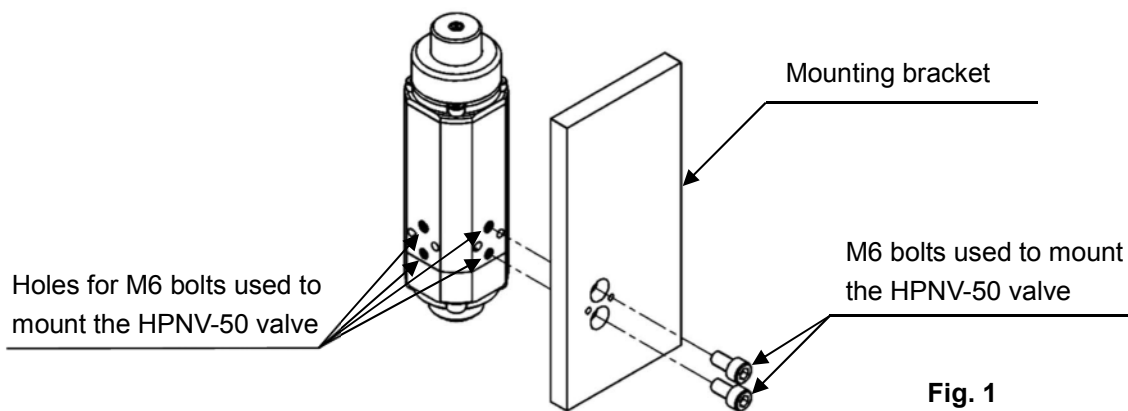

Fig. 1

2.1 Installing procedure

2.1.1 Installing by the use of positioning pins (see Fig. 2)

Holes for positioning pins are provided to prevent misalignment of the installed position during replacement of the valve. These pins ensure repeatable installation of the valve in the correct position.

- Use positioning pins of 4 mm in diameter and g6 type.
- Holes for positioning on the valve side are of H7 type, 4 mm in diameter, and 6 mm in depth. (The hole on one side is a slotted hole.)

⚠ CHECK Positioning Pins Only are not enough to fix the valve.

Securely fix the valve with two or four bolts before use.

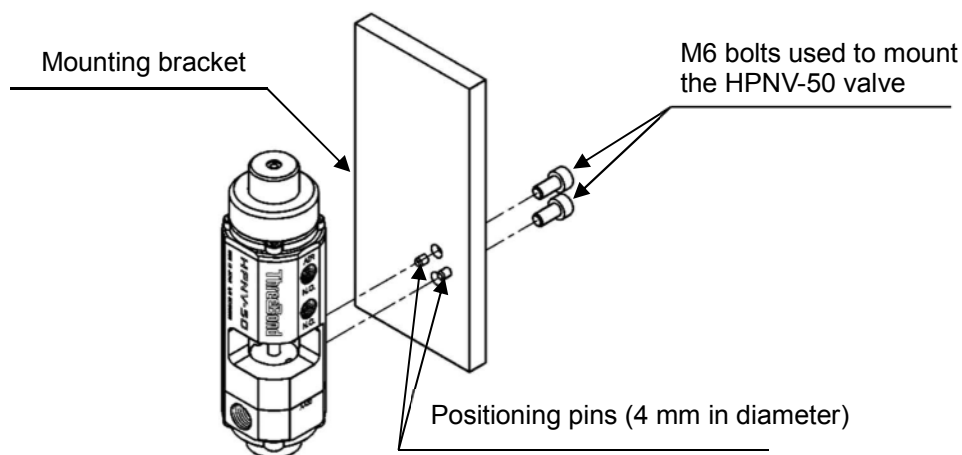

Fig. 2

HPNV-50

2.1.2 Replacement of conventional valve

The mounting position (location of holes for bolts) of the HPNV-50 valve is compatible with that of the conventional valve (see Fig. 3).

⚠ **CHECK** Securely fix the valve with two or four bolts before use.

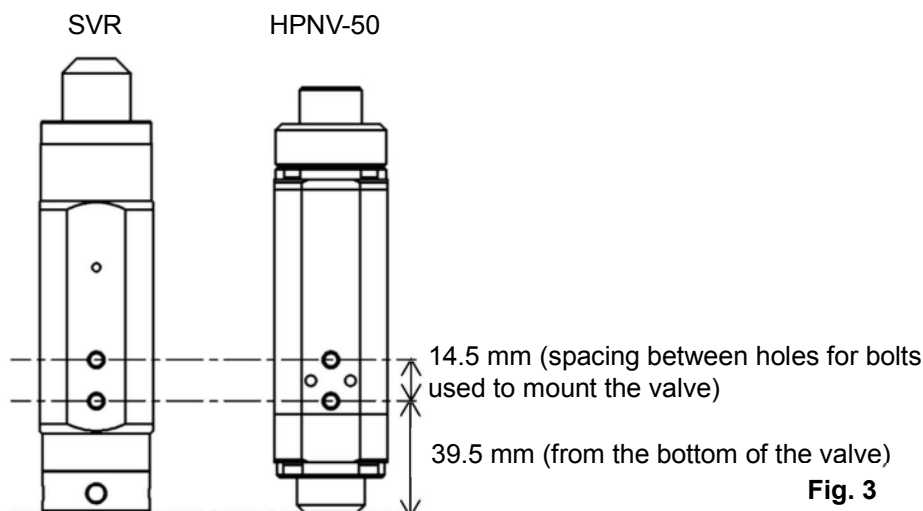

- When the conventional valve was mounted by positioning with reference to two or three surfaces including the bottom surface use as an option a dedicated spacer to position it with reference to the bottom surface (see page 18).
 - Place the optional dedicated spacer on the liquid outlet side of the valve (see Fig. 4)
- Note: Attach the dedicated spacer to the valve with the O-ring located in the spacer.

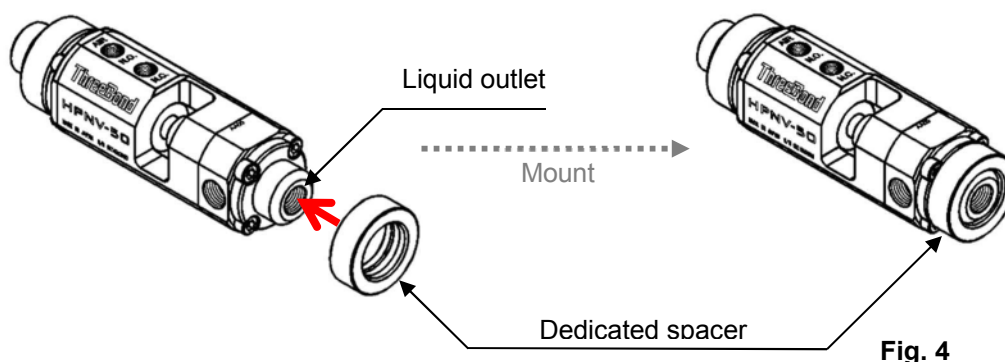

⚠ **CAUTION** When the conventional valve was not positioned with reference to the bottom surface, attaching the dedicated spacer to the valve may cause the spacer to come off and fall due to vibration, etc.
When the valve is not positioned with reference to the bottom surface, do not use the dedicated spacer.

3. Connection

3.1 Air hose connection ports

Connect an air fitting to the air connection hose port, respectively (see **Fig. 5**).

- Air hose connection port N.O.: Rc 1/8 (see **Fig. 6**)
- Air hose connection port N.C.: Rc 1/8 (see **Fig. 6**)

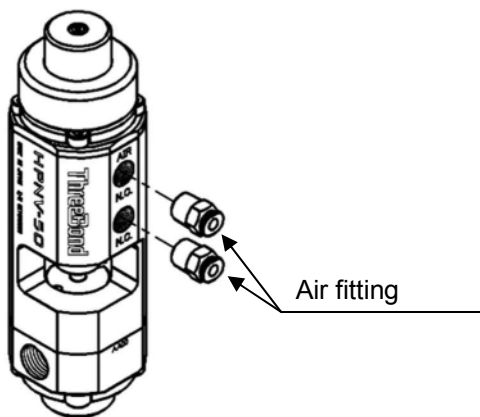

Fig. 5

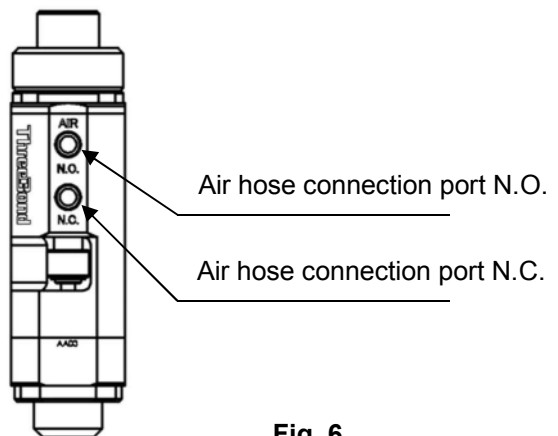

Fig. 6

Air hose connection

- Connect an air hose to the connection port stamped “N.O.” and “N.C.” on the valve, respectively, as shown in the pneumatic circuit diagram (see **Fig. 7**).
- It is recommended to mount a quick exhaust valve near the HPNV-50 valve to prevent condensation in the air lines.
 - ▶ Quick exhaust valve: SMC-made AQ240F, PISCO-made EQU, or KOGANEI-made MTV4

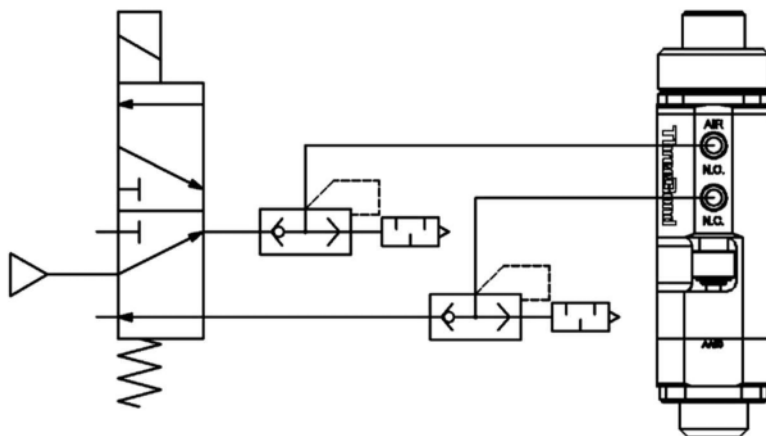

Fig. 7

Recommended specification for solenoid

- 5-port 2-position or 4-port 2-position
- Flow characteristic, $C[\text{dm}^3/(\text{s} \cdot \text{bar})]$: 0.54 or more, b : 0.12 or more, C_v : 0.12 or more

Note: Specification for solenoid mounted within a ThreeBond Coater SIII

HPNV-50

3.2 Liquid hose connection ports

Mount a material fitting suitable for the material feed method chosen to the liquid connection port, respectively.

- Liquid inlet port IN: Rc 1/4 (see **Fig. 8**)

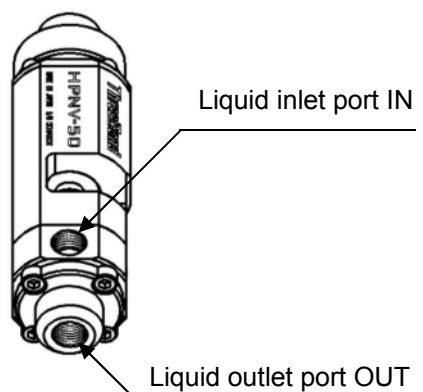

Fig. 8

3.3 Nozzle connection

Connect a nozzle or nozzle block dedicated to the HPNV-50 valve to the liquid outlet port OUT (see **Fig. 9**).

- Liquid outlet port OUT: Rp 1/4 (see **Fig. 8**)
- For the nozzle, use a ThreeBond nozzle or nozzle block dedicated to the HPNV-50 (see **page 19**).

! **CAUTION** Using any nozzle not recommended by us may result in troubles, such as damage to the liquid outlet port threads or liquid leakage due to faulty mounting of the nozzle.

- Securely tighten the nozzle or nozzle block to the HPNV-50 valve until the nozzle comes into contact with the outlet, and then ensure that it has been completely tightened.

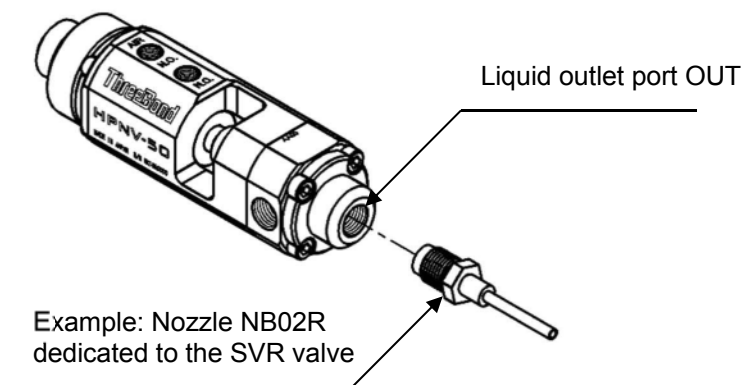

Fig. 9

HPNV-50

4. Operation

4.1 Valve operation and discharge operation

The HPNV-50 valve can open and close by switching air supplied to the cylinder's N.O and N.C. air inlets.

- The opening and closing operation of the valve can be checked through the visual inspection window for maintenance (see **Fig. 10**).
- Feed liquid to the valve, and then open and close the valve. The liquid can be discharged when opened.

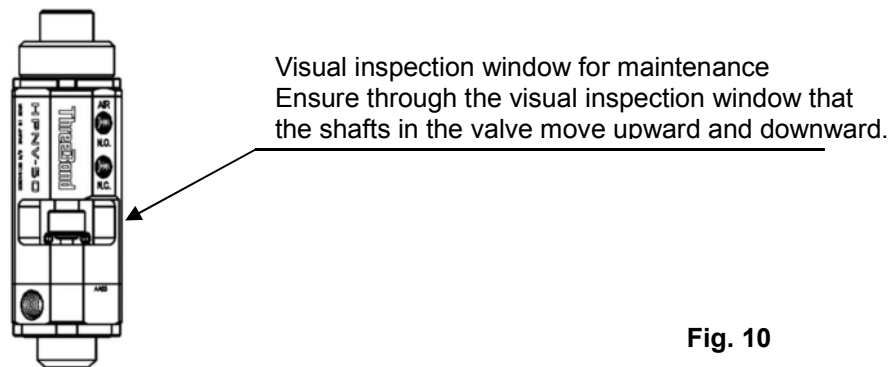

Fig. 10

4.2 Adjustment of stroke length

The flow rate of liquid can be adjusted by making adjustment to the stroke length of the cylinder.

Note: The stroke length is set to 2.0 mm at the time of shipment from the factory.

- Loosen the M3 lock bolt that fixes the stroke length control so the head of the lock bolt protrudes by 6 mm, and then turn the control with your fingers to make adjustment to the stroke length (see **Fig. 11**).
- The stroke length control can be turned with little force by loosening the M3 lock bolt.

CAUTION Forcibly turning the stroke length control without loosening the M3 lock bolt may cause damage to the valve.

Be sure to turn off supply air and liquid feed pressure before making adjustment of the stroke length.

Pay careful attention not to get your finger caught between the M3 lock bolt and the stroke length control.

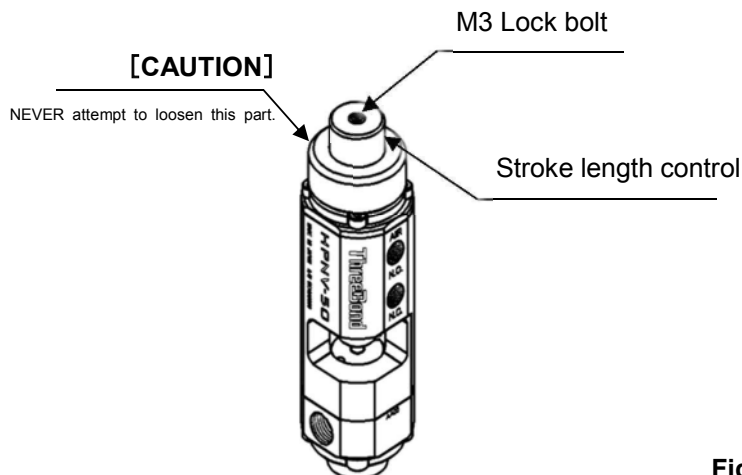

Fig. 11

HPNV-50

- Turn the stroke length control clockwise (i.e., to the right) to reduce the stroke length. Turn it counterclockwise (to the left) to increase the stroke length. (See Fig. 12.)
- Every time you turn the stroke length control by 1 notch, you hear it “click.”

Note: 1-notch turn of the control gives 0.1-mm stroke length. One full turn (i.e., 10-notch turn) of the control gives 1-mm stroke length.

Note: Be sure to stop turning the stroke length control and set it in a position where you hear it “click.”

Turn the control counterclockwise (i.e. to the left) to increase the stroke.



Turn the control clockwise (i.e. to the right) to reduce the stroke.

Fig. 12

Procedure for making adjustment of stroke length

- (1) Loosen the M3 lock bolt that fixes the stroke length control so the head of the lock bolt protrudes by 6 mm.
- (2) Turn the stroke length control clockwise (i.e., to the right) until it stops to reduce the stroke length.

Note: Set the stroke length to 0 mm.

- (3) From this state, turn the stroke length control counterclockwise (i.e., to the left) to achieve your desired setting of the stroke length.

Note: To set the stroke length to 2.0 mm, turn the control by 20 notches.

Note: The stroke length is adjustable with a range of 0.0 mm to 4.0 mm (up to 40 notches).

- (4) Tighten the M3 lock bolt of the stroke length control to finalize the control setting.



CAUTION NEVER attempt to turn the part located at the bottom of the stroke length control (see Fig. 11).

Loosening or dismounting this part may cause damage to the stroke length adjustment mechanism.

Be sure to turn the stroke length control by fingers without using any tools.

If the control cannot be turned by fingers, check whether the lock bolt is loosened, and then whether the stroke is located at the fully open or fully closed end.

If you feel any abnormality, ask for repair of the valve.



CHECK If the valve is used for a long period of time, the stroke length will increase due to wear of the valve seat.

This makes changes to the valve, such as an increase in the flow rate.

Make periodic adjustment of stroke length to correct flow rate as needed.

5. Maintenance Check

5.1 Check items

Check the following before starting work each time:

- Open and close the valve to ensure that it operates normally;
- Check for any leaks of liquid from the needle shaft; and.
- Check for any leaks of liquid from the nozzle with the valve closed.

⚠ **CHECK** In the event of any of the phenomena listed above, you are required to take appropriate action referring to information in the “6. Troubleshooting” section on page 16.

Liquid leakage from the Needle Shaft

- When using the valve, liquid inevitably leaks from the needle shaft due to wear of packing. The period of time when liquid leaks from this location varies with the type of liquid in use.
- When liquid leaks from the needle shaft, immediately replace the valve or the material chamber in order to continue the valve use for a long period of time.

⚠ **CAUTION** Leaving liquid leakage from the needle shaft as-is without taking any action may cause the valve to malfunction.

Furthermore, if leaked liquid gets cured and adheres to the material chamber, it may not be replaced.

⚠ **CHECK** **Image 1** shows an example where no immediate action was taken for liquid leakage from the needle shaft.

The material chamber should be replaced before it is put into such a state, i.e., before liquid leaking from the needle shaft comes into contact with the coupler.

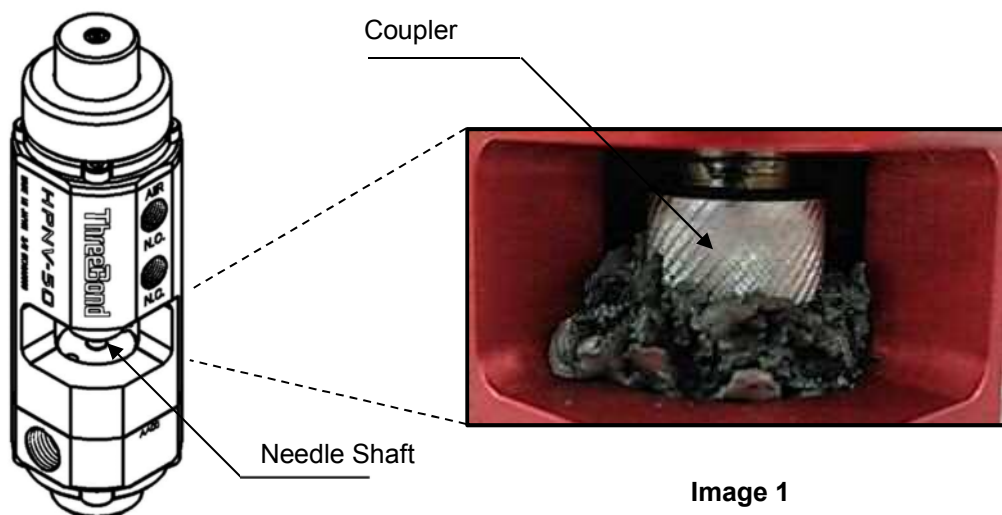

Fig. 13

Image 1

5.2 Overhaul

Request for overhaul

- To make a request for overhaul of the valve or the material chamber, contact your ThreeBond representative and provide necessary information (including the model and serial number of the valve, part number of liquid in use, details of overhaul, and other requirements).
- The conditions of the valve are checked during overhaul.
As the result of the check, some parts may need to be repaired (or replaced) due to damage.
Note: If such parts need to be repaired, we contact you to make sure that the parts should be repaired.
- We dismount parts that were mounted to the valve when we receive it (such as air fittings, material fittings, nozzle, etc.) and return them as-is to you.
Note: If you want us to clean parts (such as fittings), let us know when making a request for overhaul.
- When you make a request for overhaul of the material chamber only, we will not disassemble and clean the drive unit.
If we find any abnormality in the drive unit in the course of checking operation, we will contact you accordingly.

If you have any questions, contact your ThreeBond representative.

Overhaul fees

- Overhaul fee consists of basic fee and additional fee.
Note: The basic fee is incurred every time.
 - (1) Overhaul of valve (drive unit and material chamber)
Disassembly, cleaning, replacement of consumables (packing and O-ring), reassembly, and check of operation
 - (2) Overhaul of material chamber only
Disassembly, cleaning, replacement of consumables (packing), reassembly, and check of operationNote: Basic fee is set to each overhaul.
Note: Contact your ThreeBond representative as to the basic fee.
- Additional fees are incurred in the event of any of the following events:
 - (1) Repair (including replacement of parts)
Cost of parts replaced and labor charge for the replacement
 - (2) Complete curing of liquid in the material chamber
Labor charge incurred when a period of time taken to disassemble and clean the material chamber substantially exceeds the standard time set by us
 - (3) Request for cleaning parts (joints)
Labor charge incurred for cleaning them

To save additional fee:

- In the event of liquid leakage from the needle Shaft, stop using the valve, and then take immediate action.
- When making a request for overhaul, put tape or a plug on the inlet and outlet ports of liquid in order to prevent liquid in the material chamber from curing (preventative measure)

HPNV-50

5.3 Procedure for replacing material chamber

⚠ WARNING Be sure to turn off supply air and liquid feed pressure before replacement.

(1) Remove the four M5 bolts that connect and fix the material chamber (see **Fig. 14**).

Note: To remove the bolts, gradually loosen in a diagonal pattern (see **Fig. 15**).

(2) Lift the coupler between the drive unit and the needle shaft, disconnect these parts, and then remove the material chamber (see **Fig. 16**).

⚠ CAUTION Pay careful attention not to cause the material chamber to fall when disconnecting these parts.

(3) Remove the material chamber, and then mount a new material chamber.

⚠ CHECK Before mounting the new material chamber, wipe debris from the hole of the drive unit in which the material chamber is inserted with a waste cloth (see **Fig. 17**).

Mounting the material chamber with debris/cured material within the drive unit may cause damage to either part.

(4) Lift the Coupler, and then reconnect the drive unit and the needle shaft (see **Fig. 16**).

(5) Reconnect and fix the material chamber with the four M5 bolts (see **Fig. 14**).

Note: To tighten the bolts, gradually tighten on diagonal line (see **Fig. 15**).

⚠ CAUTION Check for any loose bolts.

Using the valve with the bolts not securely tightened may cause damage to it.

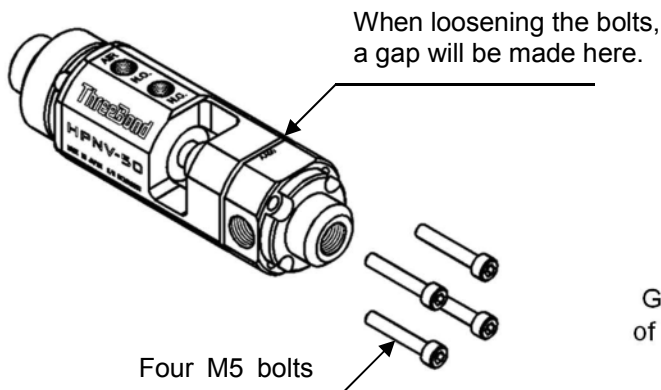
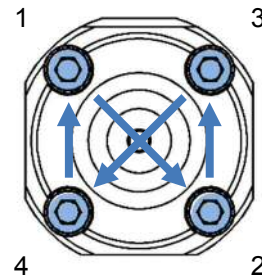

Fig. 14



Gradually tighten or loosen the bolts in the order of 1→2→3→4→1→2→3→4... for a few rounds.

Fig. 15

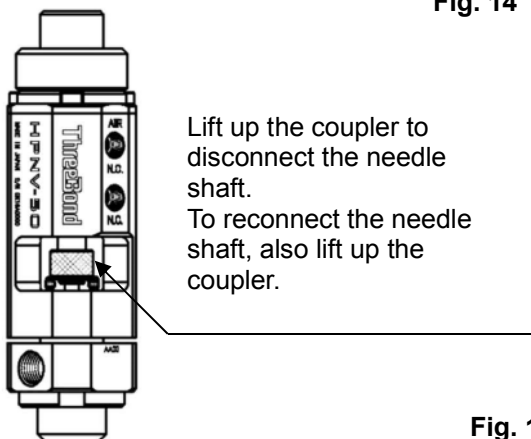

Fig. 16

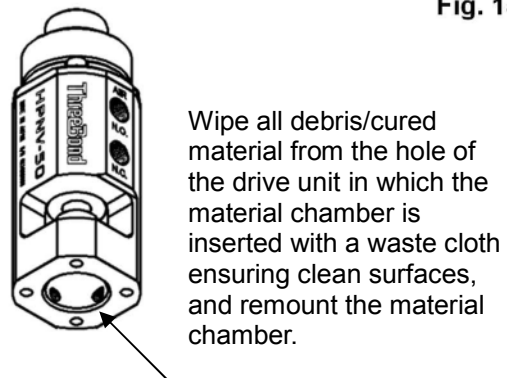

Fig. 17

6. Troubleshooting

6.1 Action to be taken in the event of trouble

- In the event of trouble, turn off the supply source of compressed air used to drive this product and turn off pressure-feed liquid.



CAUTION Do not use this product until the root cause of trouble is corrected.

- If this product causes trouble, immediately contact your ThreeBond representative.

Note: We deal with the trouble under our warranty dependent on the root cause. (This applies only during the warranty period).

Note: Do not disassemble the product. Make a request for us to repair, check, and overhaul it.

6.2 Troubleshooting

Trouble	Supposed Cause	Countermeasure
Poor material flow - Stopping of material flow	Air entrapped in the material chamber	Thoroughly purge air from the material chamber.
	Scratches on the packing or needle retainer caused by foreign material that is mixed in the liquid	Replace the valve or the material chamber. Ask ThreeBond to repair or overhaul the valve or the material chamber separately.
	Deteriorated sealing performance of the packing due to its normal wear	
	Malfunction of the valve	Check whether the primary compressed air supply is cut off. Replace the valve. Ask ThreeBond to repair or overhaul the valve.
Malfunction – No cycling of valve open/close	Faulty connection of the drive unit and the material chamber	Ensure that the drive unit and the material chamber are properly connected.
	Damaged drive unit	Replace the valve. Ask ThreeBond to repair or overhaul the valve dismantled.
	Faulty solenoid valve	Replace the solenoid valve with new one.
Liquid leakage from the needle Shaft	Scratches on the packing caused by foreign material that is mixed in the liquid	Replace the valve or the material chamber. Ask ThreeBond to repair or overhaul the valve or the material chamber separately.
	Deteriorated sealing performance of the packing due to its normal wear	

HPNV-50

Trouble	Supposed Cause	Countermeasure
Normal coating cannot be applied: <ul style="list-style-type: none"> · Coating bead becomes wavy. · Coating bead suddenly becomes thin. 	Too much clearance (distance) between the nozzle and object to be coated	Make adjustment of clearance between the nozzles and the object to be coated.
	Reduced liquid feed pressure	Check the liquid feed pressure, and then set it to the optimal pressure.
	Insufficient discharge rate of liquid	
	Flow passage blocked by foreign material that is mixed in the valve	Replace the valve. Ask ThreeBond to repair or overhaul the valve.
	Liquid cured at the tip or inside of the nozzle	Replace the nozzle with a new one.
Normal coating cannot be applied: <ul style="list-style-type: none"> · Coating bead is broken off. · Burst sound is heard during coating. 	Air bubbles entrapped in the valve	Thoroughly purge air from the valve.
	Air bubbles that get mixed in the liquid	
Normal coating cannot be applied: <ul style="list-style-type: none"> · Coating bead gets streaked. 	Scratches on the nozzle tip	Replace the nozzle with a new one (with no scratches on it).
	Adhesion of foreign or cured material to the nozzle tip	Remove foreign or cured material from the nozzle ensuring not to scratch it.
Liquid cannot be discharged normally: <ul style="list-style-type: none"> · Liquid cannot be discharged at all. 	Liquid cured at the tip or inside of the nozzle	Replace the nozzle with a new one.
	Compressed air source turned off	Check whether compressed air is fed to the valve.
	Stroke length reduced too much	Make readjustment of the stroke length to an appropriate setting.
	Faulty connection of the drive unit and the material chamber	Ensure that the drive unit and the material chamber are properly connected.
	Faulty solenoid valve	Replace the solenoid valve with new one.
	Liquid cured in the valve	Replace the valve or material chamber. Ask ThreeBond to repair or overhaul the valve.

HPNV-50

7. Product Lineup

7.1 Standard product and spare parts

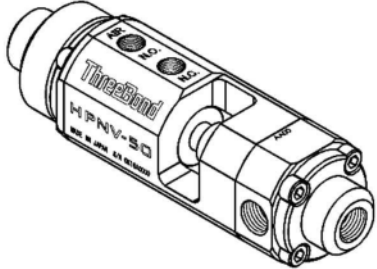
	Name	Dispensing valve HPNV-50	
	Model	HPNV-50	
	Product Code	3PQ 81734	Product in stock
	Quantity	1	
	Description	Standard product Recommended to have this product in stock as a spare part.	

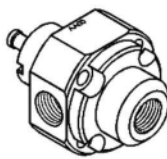
	Name	Material chamber (HPNV-50)	
	Model	HPNV-50	
	Product Code	3PQ 812600	Product in stock
	Quantity	1	
	Description	Material chamber for replacement Recommended to have this product in stock as a spare part.	

Note: The parts are not sold separately.

If needed separately, contact your ThreeBond representative.

7.2 Optional parts

	Name	Spacer (HPNV-50)	
	Model	HPNV-50	
	Product Code	3PQ 812602	Made-to-order part
	Quantity	1	
	Description	This spacer is used to make the HPNV-50 valve compatible with conventional for replacement using an existing mounting fixture. For detail, refer to information in "2.1.2 Replacement of conventional valve" on page 8. Note: 1 piece O-ring (P24) attachment	

HPNV-50

7.3 Dedicated nozzle and nozzle block

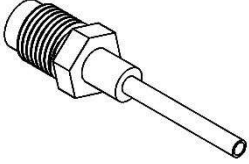
	Name	Nozzle block	
	Model	NB02R	
	Product Code	3PQ 81812R	Make-to-order part
	Quantity	1	
	Description	Specify the inside diameter and length of the nozzle. Recommended to have this product in stock as a spare part.	

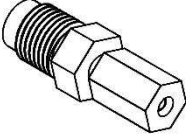
	Name	Nozzle block	
	Model	NB05	
	Product Code	3PQ 81825	Product in stock
	Quantity	1	
	Description	This nozzle block is used for the standard SUS needle nozzle. Recommended to have this product in stock as a spare part.	

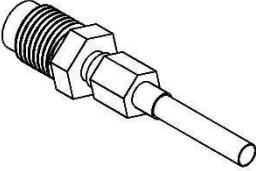
	Name	Nozzle block	
	Model	NB05A	
	Product Code	3PQ 81825A	Make-to-order part
	Quantity	1	
	Description	Specify the inside diameter and length of the nozzle. This nozzle block is designed for the nozzle (pipe) with sleeve. Recommended to have this product in stock as a spare part.	

HPNV-50

Revision History

Revisions and additions made to this Instruction Manual are listed in the table shown below.

Date of Revision	Description of Revision	Page	Responsibility

Contact

Attach your business card or your contact information.

製図年月日 DRAWING DATE
2016年05月10日

図番 DRAWING NO.
TB31601A01

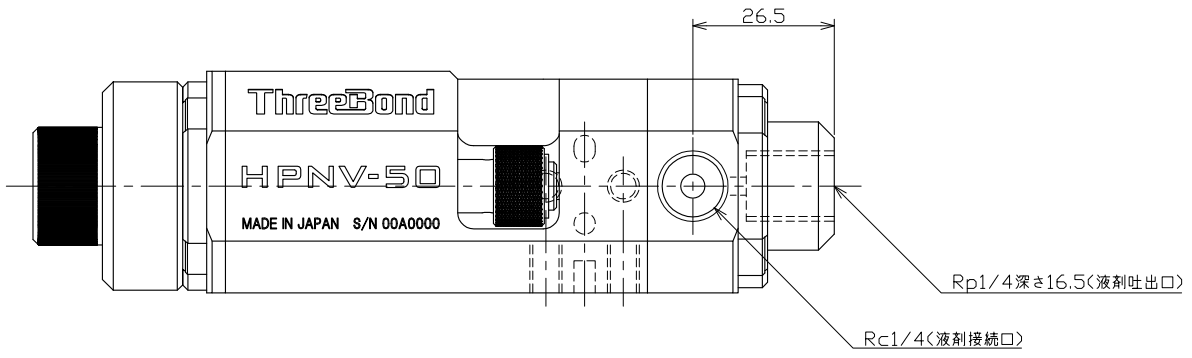
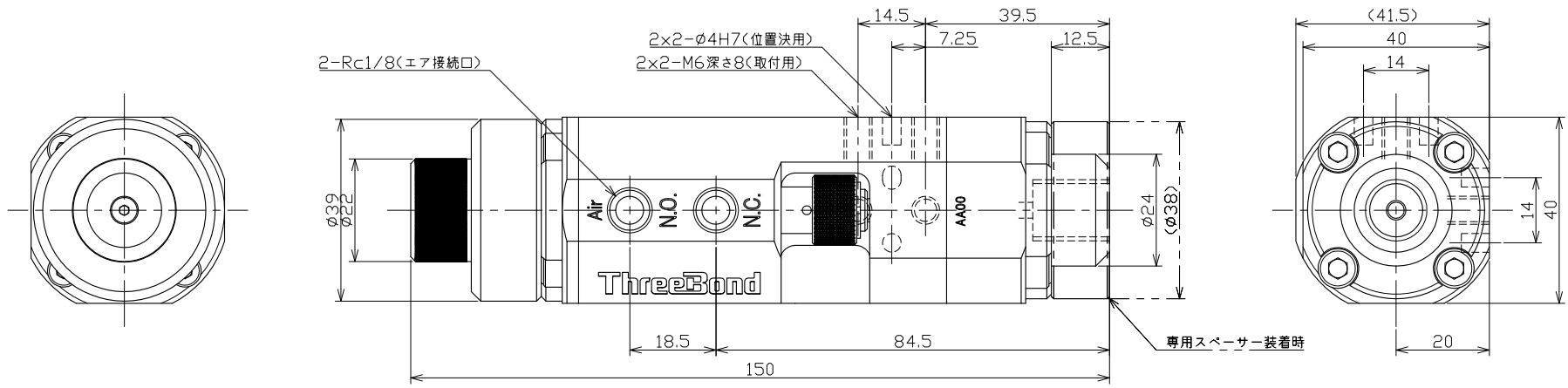

4 3 2 1								材料 MATERIAL -	表面処理 SURFACE TREAT -	尺度 SCALE 1:1	製図年月日 DRAWING DATE 2016年05月10日	名称 TITLE HPNV-50
								素材寸法 MATERIAL SIZE W40xD41.5xH150	処理 FINISHING -	単位 UNITS mm	製図 DRAWING ENDO.K	設計 DESIGN ENDO.K
								ThreeBond			検査 CHECKED KIBE.H	承認 APPROVED KIBE.H
								本図面上に記載されている全ての事項の所有権は株式会社スリーボンドに属するものであり、無断で複写、謄写、転写することを禁止する。 All proprietary rights in the subject matter hereof are reserved by ThreeBond Co.,Ltd. Unauthorized use prohibited.				図番 DRAWING NO. TB31601A01
注記 NOTES	記号 MARK	年月日 DATE	記事 REMARKS	承認 APPROVED	担当 REVISED	その他 OTHER						