

Magnetic gear wheel encoder RGM2G-A with analog output signals

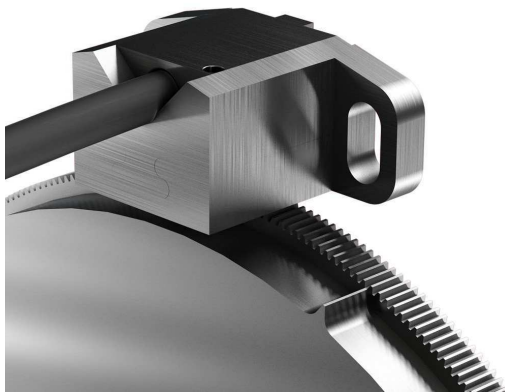

Contactless incremental encoder for measuring rotary motion

- High-resolution measurement of rotational speed and rotational angle up to 100,000 RPM
- Rotational direction recognition
- Robust, not sensitive to dirt
- Temperature stability up to 110°C

- High EMC and ESD stability (up to 30kV)

- Use in drive spindles of machine tools
- Installation in drive motors

- "safety integrated" certified

Data logger, PuV interface, Condition monitoring

- PuV-interface for communication with the encoder over the supply cable

- Electronic type label
- Operating hours counter
- Monitoring (data logger) of revolution speed, encoder temperature et al.
- Storage of user information

- Automatic self-calibration of signal parameters
- Automatic stabilisation of signal amplitudes

Output signals

- analog, SIN- and COS signals with 1Vpp
- Reference signal

Principle of measurement

- Magnetic, contactless gauging of the steel gear wheels with module $M = 0.3, 0.4$ or 0.5
- Use of magneto-resistive (GMR) sensor elements

Design

- Robust metal sensor housing
- Frontal coverage of the sensor elements using metal foil to act as extra protection against ESD impulses
- Complete sealing of sensor interior
- Screened connection cable with AWG28
- Optional connector plug

RGM2G-A...-...3

... for gear wheel module $M = 0.3$

RGM2G-A...-...4

... for gear wheel module $M = 0.4$

RGM2G-A...-...5

... for gear wheel module $M = 0.5$

Magnetic gear wheel encoder RGM2G-A Specifications

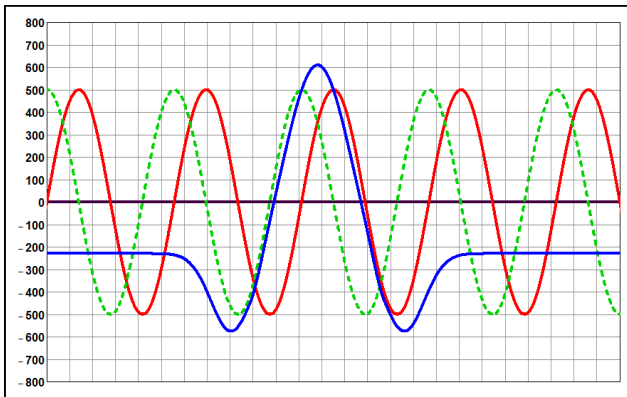

Typical signal aspect. The signal spurs A, B and Ref. are depicted.

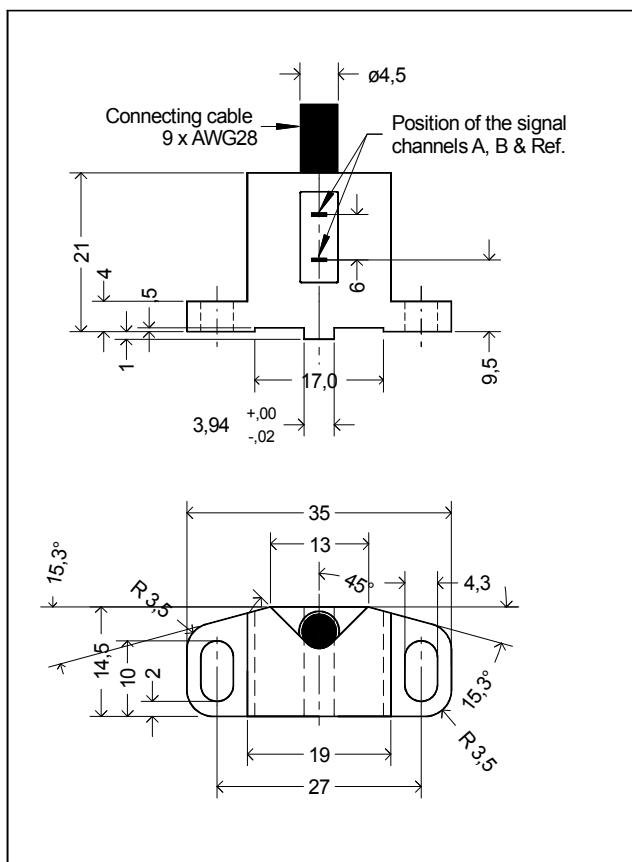

Signal parameters

Before delivery, each encoder is balanced at the nominal distance encoder - gear wheel $d_0 = 0.15\text{mm}$ (for $M = 0.3$) and 0.3mm (for $M = 0.4$ or 0.5) on optimal signal values (amplitude $1 V_{pp}$, offset 0 mV , phase 90° , unambiguity of the reference pulse; signal aspect type - see figure)

The signal parameters may deviate from the optimal values due to subsequent tolerances of attached parts, gear wheel quality and the influence of temperature and rotational speed.

- Signal type Analog, differential signals
SIN (spur A),
COS (spur B)
Ref. pulse
Inverted signals A, B & Ref.
- Signal amplitude A & B $1V_{pp} \pm 20\% *$
- Amplitude differential A/B $0.9 \dots 1.1 *$
- Phase A to B $90^\circ \pm 1^\circ$
- Offset - static $\pm 30\text{mV}$
- Freq. of measurement f $0 \dots 200\text{kHz}$

* for $U_B = 5\text{VDC}$, $f < 1\text{kHz}$

General parameters

- Supply voltage U_B $5\text{VDC} \pm 5\%$
- Wattage without load 80mA
- Reverse voltage protection
- Short-circuit proof
- Operating temperature $-20 \dots 85^\circ\text{C}$
(up to 100°C on request)
- Storage temperature $-30 \dots 110^\circ\text{C}$
- Optimal distance d_0 encoder - gear wheel
 $0.15 \pm 0.02\text{mm}$ für $M = 0.3$
 $0.30 \pm 0.02\text{mm}$ für $M = 0.4$
 $0.30 \pm 0.02\text{mm}$ für $M = 0.5$
- Vibration resistance up to 200 m/s^2
- Shock resistance up to 2000 m/s^2
- Type of protection IP68

Magnetic gear wheel encoder RGM2G-A a smart connected sensor

The magnetic gearwheel encoders with PuV-interface are 'smart-connected' sensors, i.e., they are 'intelligent' and able to communicate. Several additional features are integrated in the magnetic gear wheel encoders of the RGM2G-A which:

- ... significantly simplifies the installation of the encoder
- ... allows individual evaluation of the behavior of the spindle
- ... enables saving specific information about the encoder and/or spindle
- ... simplifies the optimum process control of the tool spindle (e.g. utilization of the service intervals).

PuV - interface

The PuV interface allows the encoder to communicate directly via the connecting cable (connector). No additional cables are required. There is no need to change the assignment of the encoder connector sockets.

The realization of the PuV-interface was achieved with a modification of the signal line for the reference signal (Ref+ and Ref-). In normal operation, the reference signal is still available. This means there is no limitation of *safety integrated-compliance*.

First gearwheel encoders with PuV 2.0 interface were introduced in 2012. PuV 3.0 gearwheel encoders are available since September 2015.

PuV 3.0 encoders are compatible with PuV 2.0 encoders. Differentiation between these two types is possible with the order identifier, for example:

	PuV 2.0	RGM2G - AM ...
resp.	PuV 3.0	RGM2G - AE ...

Other encoder types (SGM2G, RGM2S, RGK2G u.a.) behave accordingly.

Detailed information of the essential functions of gearwheel encoders with PuV 2.0 and PuV 3.0 interface on request.

The following external devices are available for communication with the encoder over the PuV interface: **DCMU, HCU, SMU**

Automatic self calibration

If the automatic self calibration (ASC) of the encoder is activated, this calibrates automatically after mounting to optimum signal parameters. Possible deviations of the signal parameters after mounting are automatically corrected.

Different modes are available for automatic self calibration (detailed information on request). Configuration of the automatic self calibration can be carried out over the PuV interface.

Parameterizing/configuration of the different encoder features can be carried out by VS Sensorik as per customer specifications or using an original created setup file. For further details, see the software description **ProCal**.

Magnetic gear wheel encoder RGM2G-A

Application Scenarios

Standard Application - Normal Case



Monitoring and automatic self calibration run independently in the encoder, without additional external components, according to the configuration.

Configuration of the Encoder / Reading the Encoder Data / Quality Control

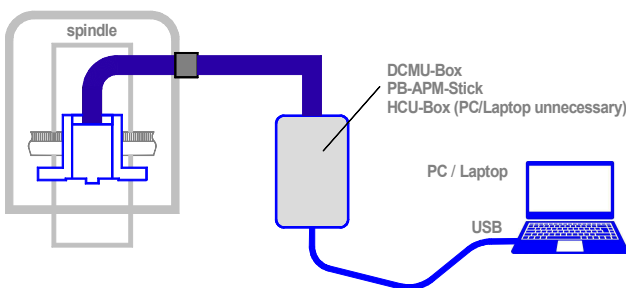

Configuration of the encoder functions or reading the data saved in the encoder is carried out using the DCMU- or HCU-Box.

Detailed information for quality control (signal parameter, gear wheel quality) is delivered over the HCU and DCMU-Boxes.

All information about the encoder (configuration settings, signal parameters) can be stored in a protocol.

Troubleshooting

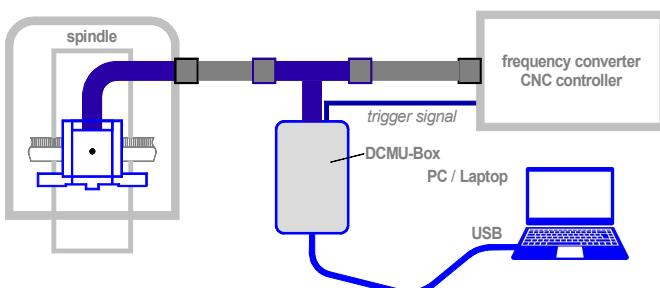

The message "Encoder Error" from the tool machine usually requires intensive investigation. Is encoder the shield system or grounding system correct? Is there strong vibration in the spindle?

In such a situation, the DCMU box with monitor functions of all encoder parameters, as well as the possibility of the external (for control of "encoder error") or internal (for defective signal values) trigger is a significant analysis tool for almost all speed ranges.

Magnetic gear wheel encoder RGM2G-A

Order identifiers

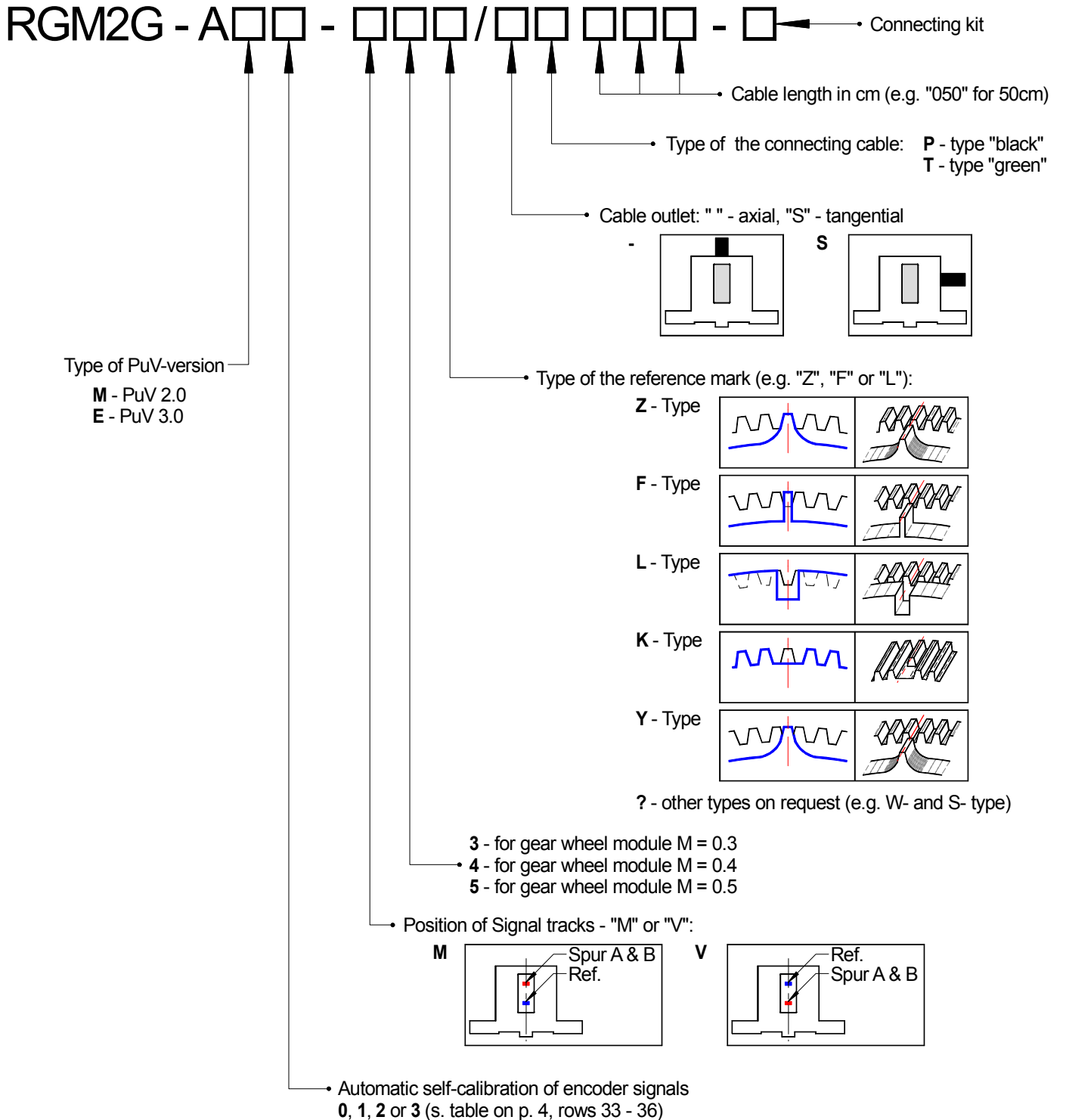

Magnetic gear wheel encoder RGM2G-A

Order identifiers - Cable assignment

RGM2G - A ... /**P** ...

RGM2G - A ... /**SP** ...

Cable type P "black"

A shielded cable with 9 wires, AWG28, is attached at the sensor output. The outer sheath is black.

The cable is assigned as follows:

- | | |
|----------------|--------|
| ■ Signal A + | brown |
| ■ Signal A - | green |
| ■ Signal B + | grey |
| ■ Signal B - | orange |
| ■ Signal Ref + | red |
| ■ Signal Ref - | black |
| ■ UB = 5VDC | violet |
| ■ GND (0V) | yellow |
| ■ RS_5V | blue |

The **shield** is connected to the casing on the encoder side.

RGM2G - A ... /**T** ...

RGM2G - A ... /**ST** ...

Cable type T "green"

A shielded cable with 9 wires, AWG28, is attached at the sensor output. The outer sheath is green according to RAL6018, based on DESINA specifications.

The cable is assigned as follows:

- | | |
|----------------|--------|
| ■ Signal A + | white |
| ■ Signal A - | brown |
| ■ Signal B + | pink |
| ■ Signal B - | black |
| ■ Signal Ref + | grey |
| ■ Signal Ref - | yellow |
| ■ UB = 5VDC | red |
| ■ GND (0V) | blue |
| ■ RS_5V | green |

The **shield** is connected to the casing on the encoder side.

RGM2G - A ... /P...

RGM2G - A ... /T...

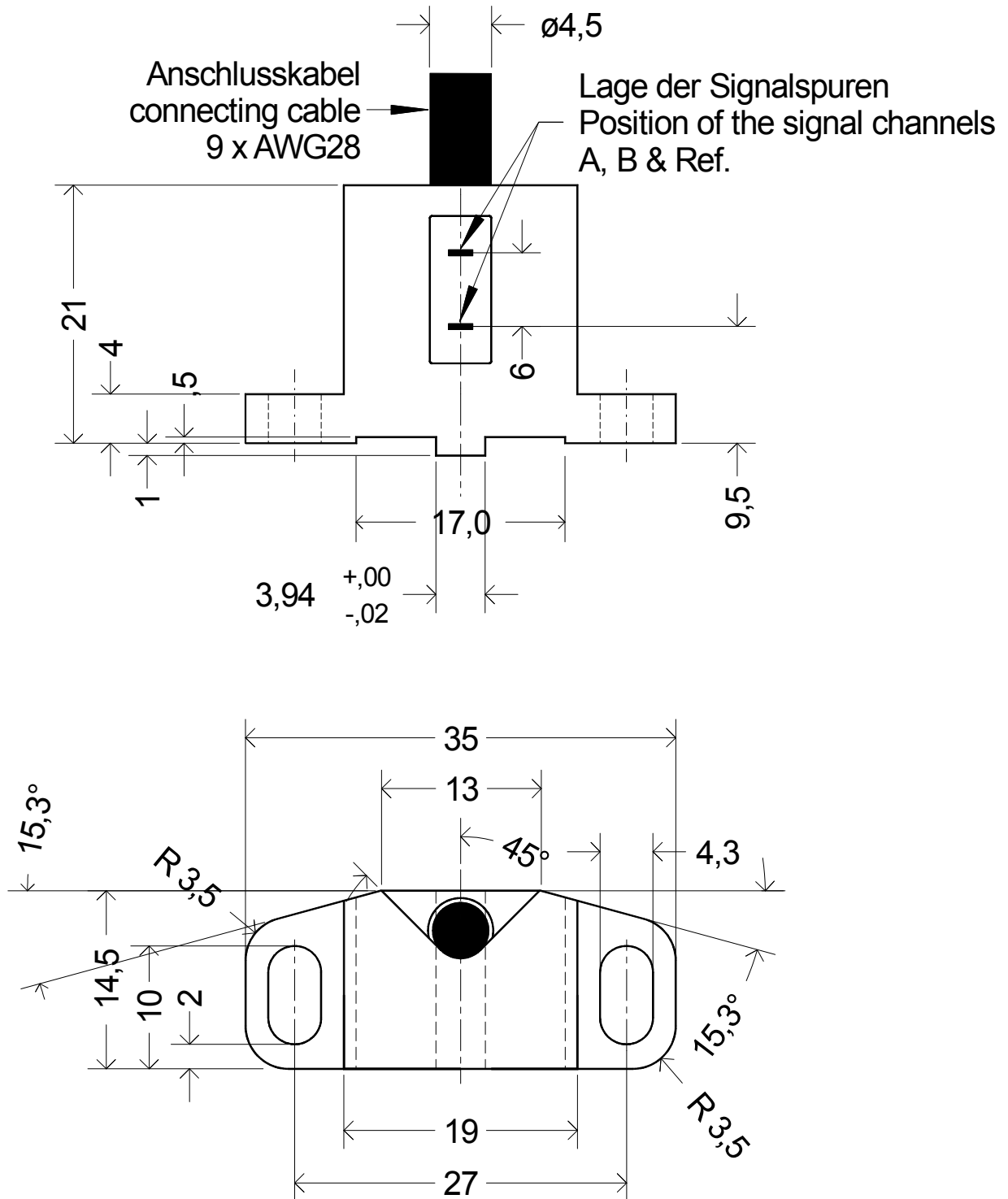

Material	Allgemeintoleranzen	Dateiname RGM_ax	Datum 27.10.09	Maßstab 2:1
VS Sensorik GmbH		RGM2G-A ... /...		
		09VS042701	Version 2	Blatt 1

RGM2G - A ... /**SP**...

RGM2G - A ... /**ST**...

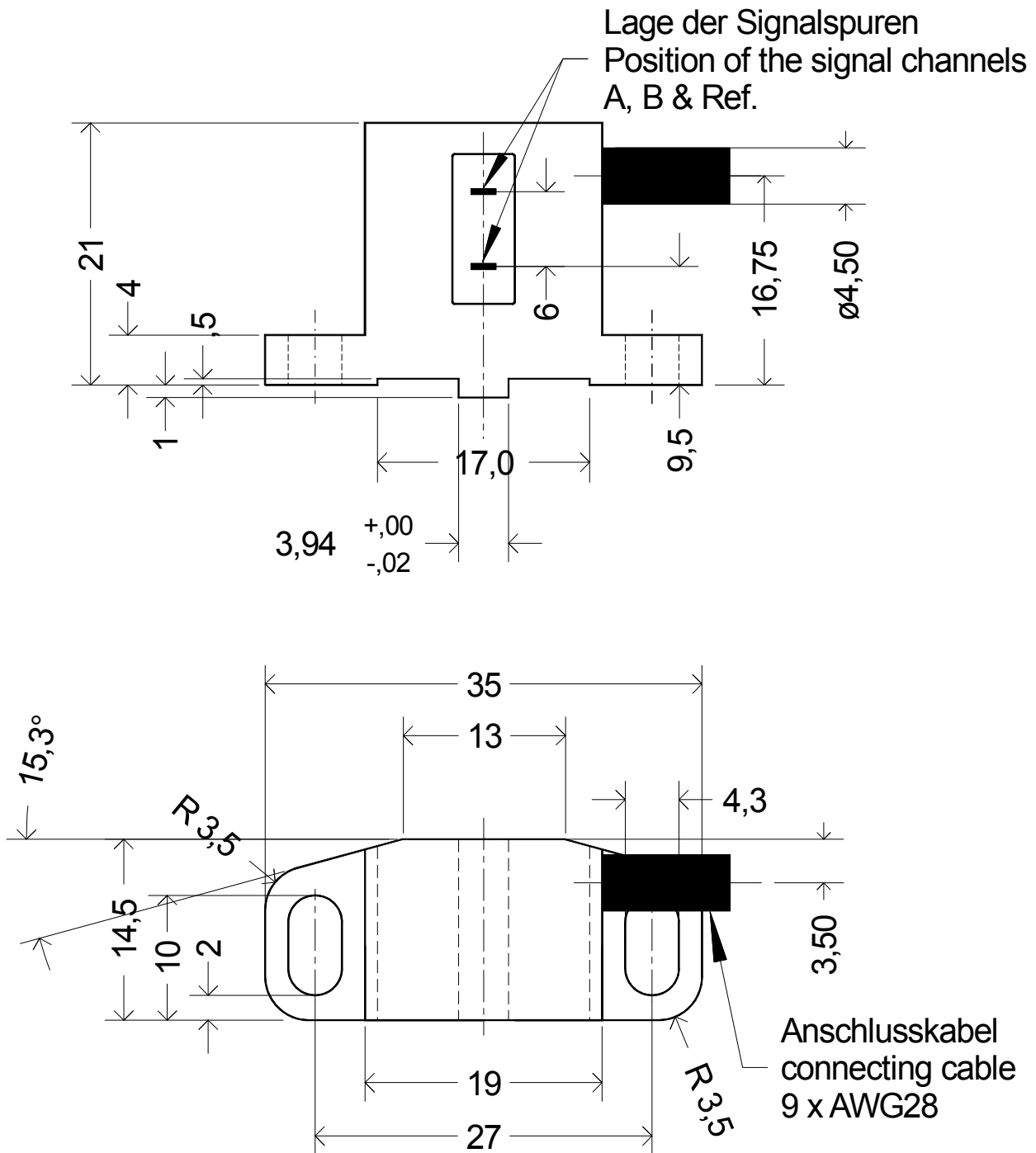

Material	Allgemeintoleranzen	Dateiname RGM_tan	Datum 27.09.2009	Maßstab 2:1
VS Sensorik GmbH		RGM2G.../S...		
		09VS091709	Version 2	Blatt 1