

Setting Standards

Circular Connectors



2012



Setting Standards

www.hummel.com

HUMMEL AG

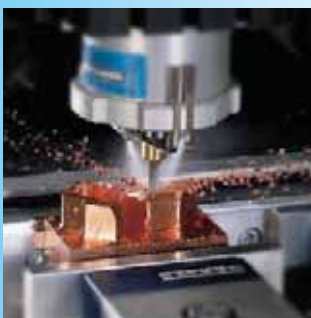



Online Catalog

- Product Pictures and Product Information
- Product and Assembly Videos
- Assembly and Operations Manual
- Technical drawings
- 3D data
- Certificates



Download-Center

- Catalog and Flyer
- Assembly instructions and installation instructions
- Press releases
- Certificates and approvals
- ...



Searching Products

- Part Number search
- Searching Details



Enclosure-Configurator

- Individual Enclosures
- Enclosure Solutions
- Online configuration, requesting and ordering



Technology Center

- Technical Information (Protection, thread, material, ...)
- Diagrams and evaluation
- Product description
- Assembly Video and Operations Manual



News of the HUMMEL AG

- Trade fairs and exhibitions
- Press releases
- New Products
- Job vacancies
- Studies, training and vocational practical training



HUMMEL divisions



Touch



Electronic



Electro technology



Heating Valves and Accessories



Metal and plastic engineering

TWILOCK

- + Quick Connect with patented Polygon Lock
- + Easy handling
- + Exceptional functionality
- + Multi functional: Ideal with Twilock and screw connection



Clearly defined Positioning

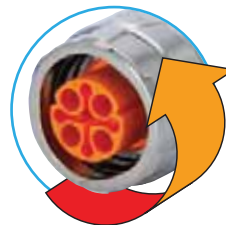

Can be locked with a slight rotation from OPEN to CLOSE



Multi functional: Special thread allows use of Twilock and screw connection

TWINTUS

The new Low-Cost-Standard for Drives

- + Minimized Size
- + Free choice of Signal and Power Inserts
- + Flange 20x20 and 25x25



CONNECTOR
4 SMALL DRIVES

TWINTUS



Colour coded inserts
(DESINA colour code)



IP67 (NEMA 4x) self sealing,
even for threaded holes



Optional EMC-sheet for separating
signal and power areas



Version M16/M12 available

M 23 Fast Ethernet PoE

- + Data transfer up to Gigabit rate, Multibus II capability
- + Hybrid connectors for combined data and power transmission
- + Five separate shield potentials available
- + Rugged, safe, compact: ideal for use in rough industrial environments

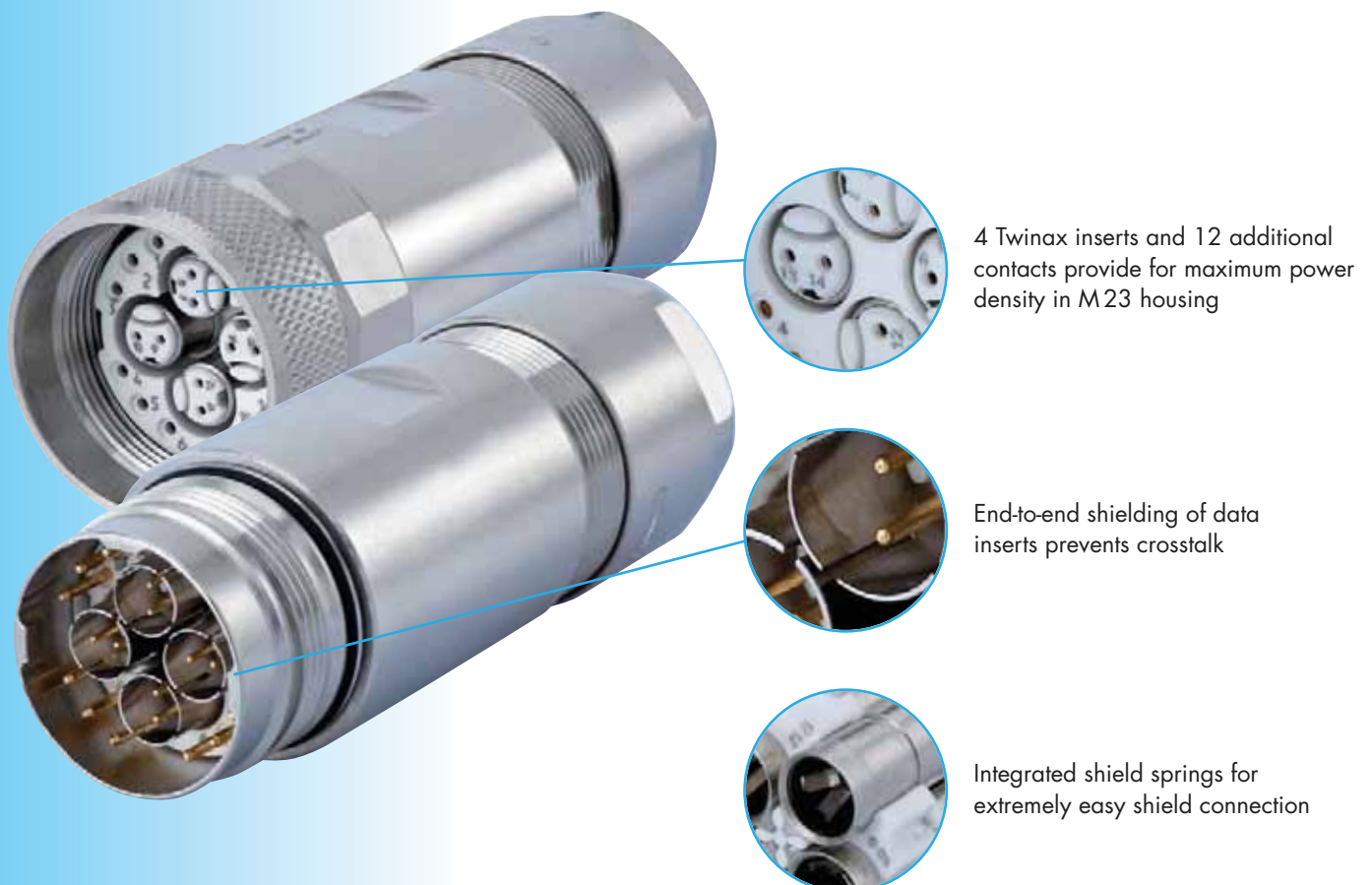

M 23 RJ 45: Robust – simple & small!



Design allows for terminated patch cable



Integrated coupler accomodates off-the-shelf RJ 45 patch cables.



Integrated cable strain relief warrant an IP 67 / IP 69 K rating making the M 23 based RJ 45 Connector an ideal solution for robust applications.

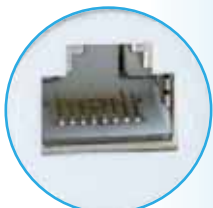

A standard RJ 45 connection is suitable as service and programmable interface.

SLS-Technology

The new, high performance type of contacts – HUMMEL SLS-Technology (Spring Loaded Socket)

- + Integrated spring mates with the pin contact and encompasses it radially
- + Exceptional electrical performance with ultimate contact reliability
- + Tinned solder contacts assure easy and quick assembly

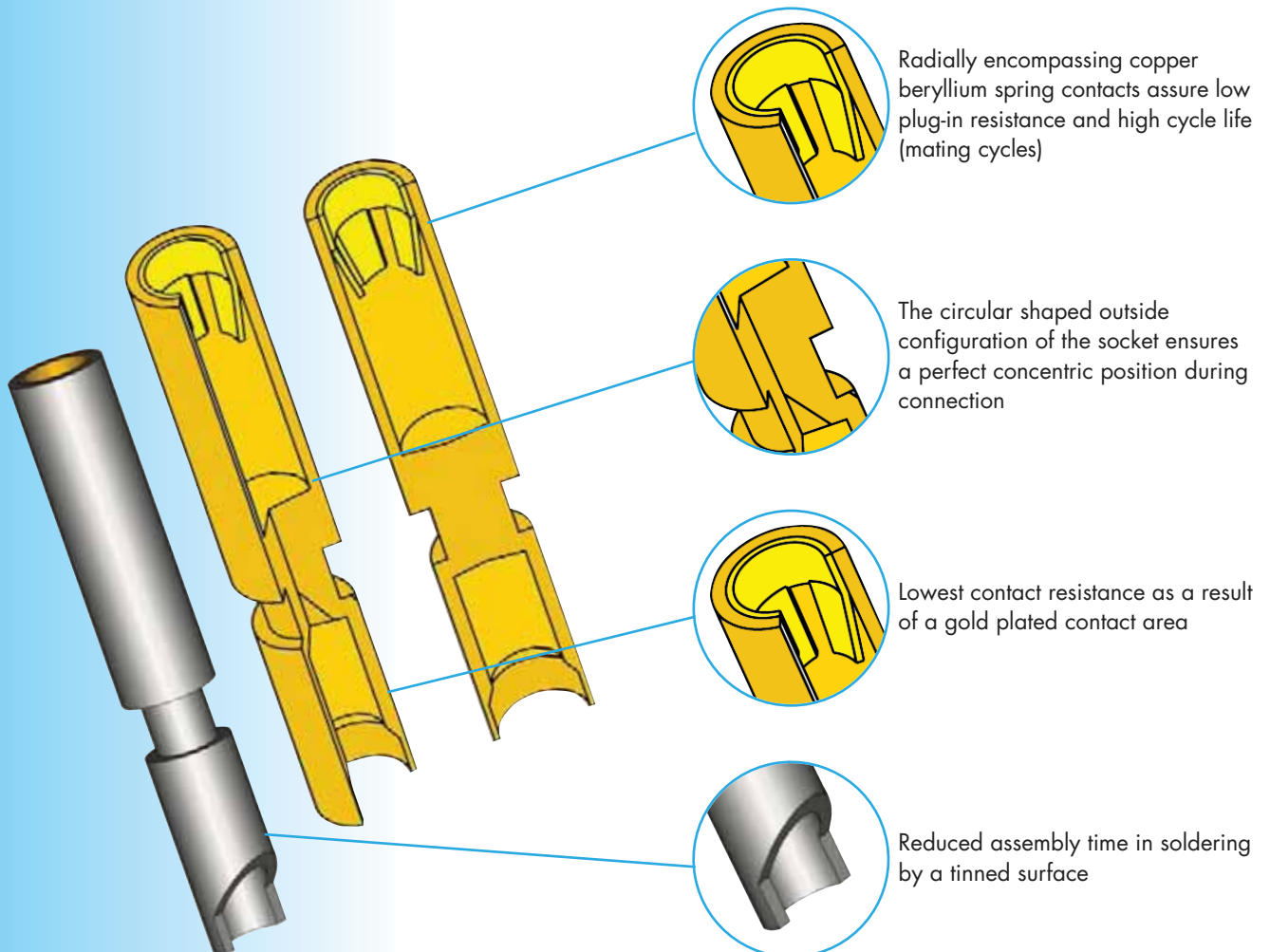

User friendly assembly

- + Clear and modular structure of all connector series
- + Patented modular strain relief insert and contact insert
- + One step cable assembly and shielding
- + Simple, quick and reliable assembly into the connector housing

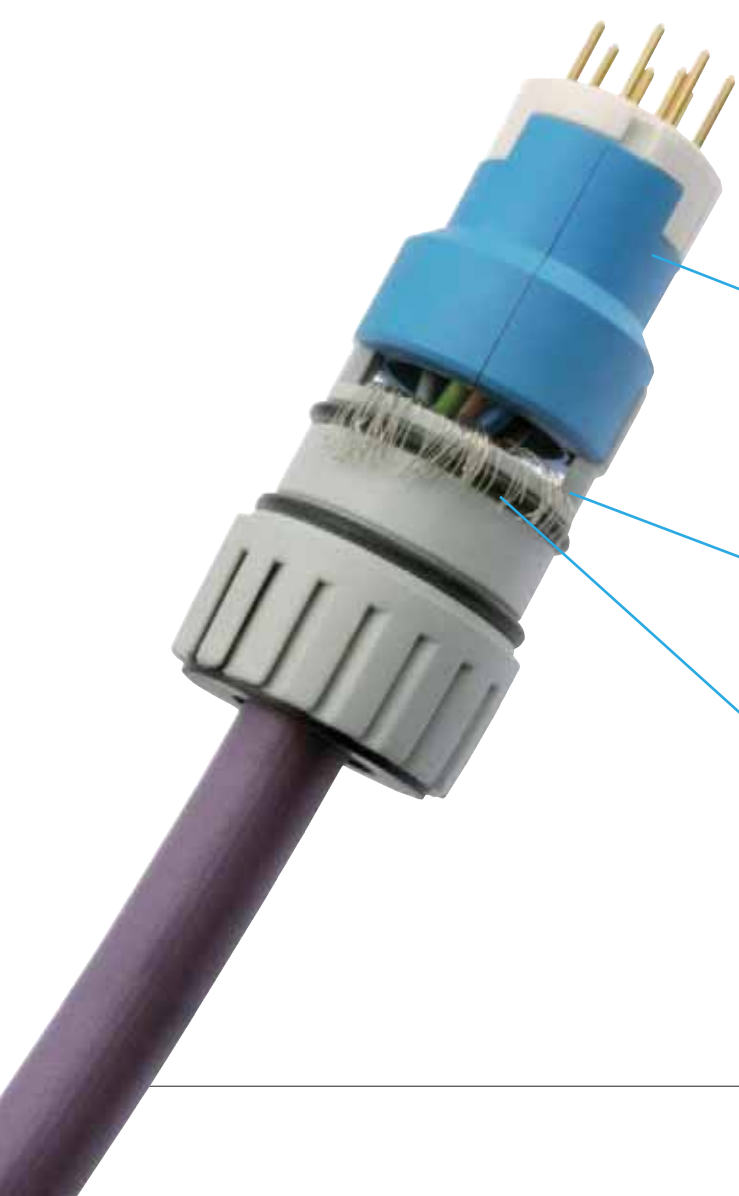

Colour coding of spacers for male and female inserts



Cable assembly and shielding is possible in a single operation.



Strain relief insert with four fingers, secured in a recess, prevents cable rotation.



Flexible EMC-O-ring guarantees reliable EMC-protection for light and heavy braided shields.

Euro-Lock-System[®]

Euro-Lock-System[®] – the patented locking system

- + The integrated locking clip secures the contacts in the insert
- + Easy assembly and disassembly of the contacts
- + No special tools required

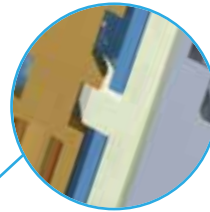
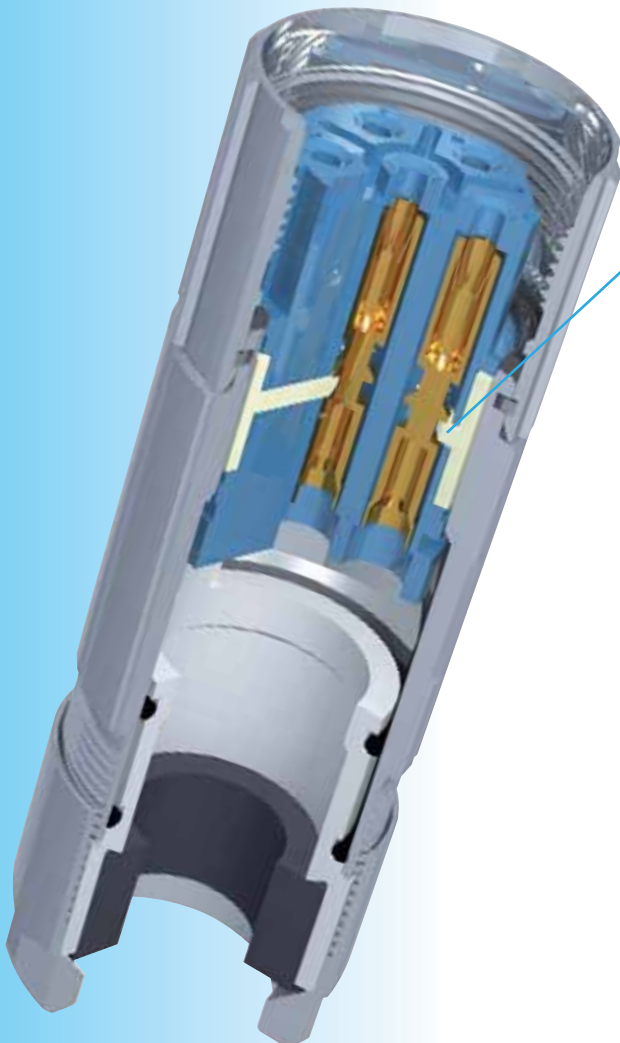

Secure contact lock



Quick assembly

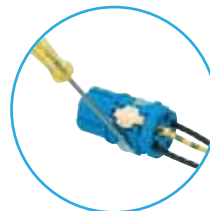

Simple contact unlocking and disassembly

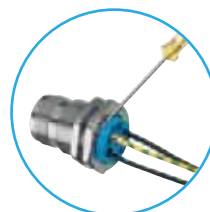

Complete assembly and disassembly without special tools

Unique Benefits

- + Interchangeability of pin or socket inserts in every style connector housing
- + integrated Liquid Tight Strain Relief Fitting
- + Internationally certified exceptional quality



File-No. E 213337



Germanischer Lloyd



Strain Relief Fitting with flex protection for cable



Flexible conduit connector



MULTI Seal Connector

The Insert – One for all

- + Insert can be used for all types of contacts
- + Crimp contacts machined or on tape
- + Solder contacts for manual soldering or dip soldered for PC boards

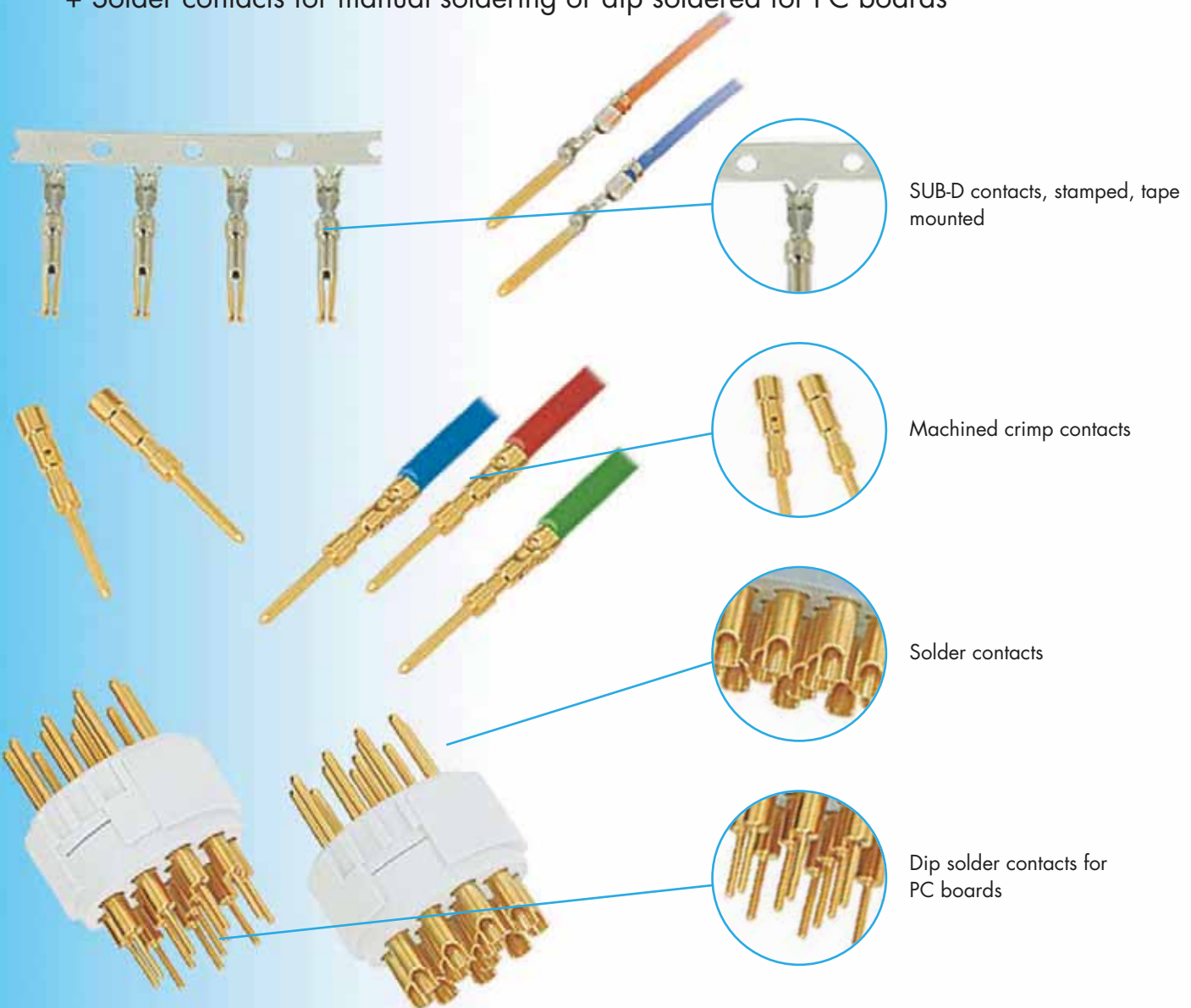



Setting the Standards	page 4
------------------------------	--------

Technical Information	page 14
------------------------------	---------

Connectors M 16	
page 15	

Connectors M 23 Fast Ethernet PoE	
page 41	

Connectors M 23 RJ45	
page 53	

Connectors Signal Size 1 M 23	
page 63	

Connectors Signal Size 1 M 27	
page 95	

Connectors Power Size 1 M 23	
page 105	

Connectors Power Size 1,5 M 40	
page 129	

Connectors TWILOCK	
page 149	

Connectors Push-Pull Technology	
page 155	

Connectors Stainless Steel (INOX)	
page 161	

Moulded Cordsets M 23	
page 169	

Custom Solutions	page 176
-------------------------	----------

Page Finder	page 182
--------------------	----------

HUMMEL International	page 183
-----------------------------	----------

Setting Standards

Technical Information

Nominal Current

Allowable current (Amp), that can be transmitted by each contact continuously and simultaneously.

Nominal Voltage

Allowable voltage (Volt), that can be applied to each contact continuously and simultaneously.

Test Voltage

Voltage which, under certain conditions, a connector can be exposed to without breakdown.

Degree of Protection

Potential dirt accumulation of a disconnected connector in a certain environment.

Degree of Protection 2

No permanent conductive dirt accumulation will occur. Temporary conductive dirt accumulation, such as condensation, is possible. Typical for households, offices, laboratories and test labs.

Degree of Protection 3

Conductive, as well as dry non-conductive dirt accumulation can occur. It can be temporarily conductive due to condensation. Typical for industrial and factory environments.

Additional remarks (pollution level)

If connectors being defined for pollution degree 1 and overvoltage category 1 are applied for other conditions (higher pollution degree and higher overvoltage category) voltages level reduce correspondingly. But the connectors can be used without any problems at reduced maximum voltages.

Mating cycles

Mating cycles are the number of insertion and extraction cycles a connector can withstand before the electrical or mechanical failure in relationship to the connector's design specification.

Air gap

The minimum gap of air between two conducting surfaces permissible at given voltage.

Creep distance

The minimum dimension along the surface of an insulating material between two conducting surfaces.

PE

The PE-Contact is a ground contact for security reasons.

Safety Guidelines

When HUMMEL connectors are used for voltages greater than 50 Volts with conductive shell components they must be used in accordance with the safety regulations DIN VDE Part 410; IEC 60364-4-41. This regulation basically dictates that the power source should be turned off before mating and unmating connector. This regulation does not provide protection against electrical shock when mating and unmating connectors in the field.



Don't connect or disconnect HUMMEL Connectors under load.

Connectors M 16

TWINTUS
inclusive



Product Overview

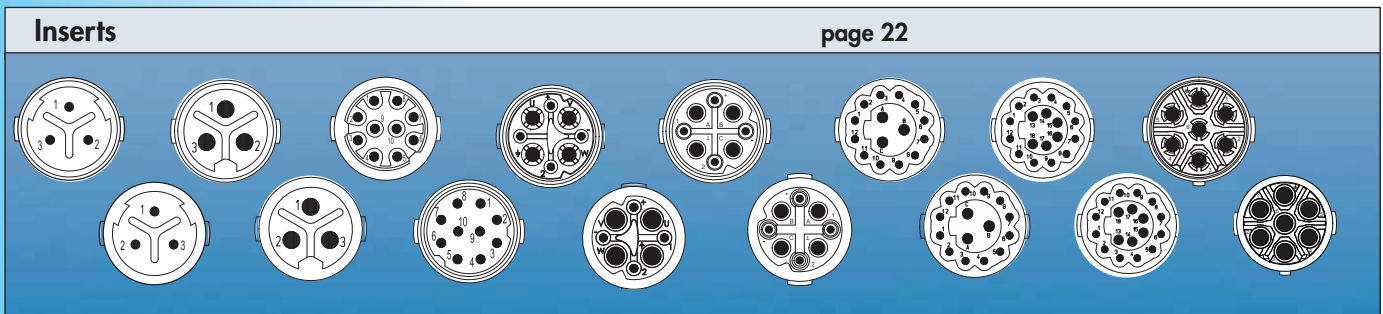
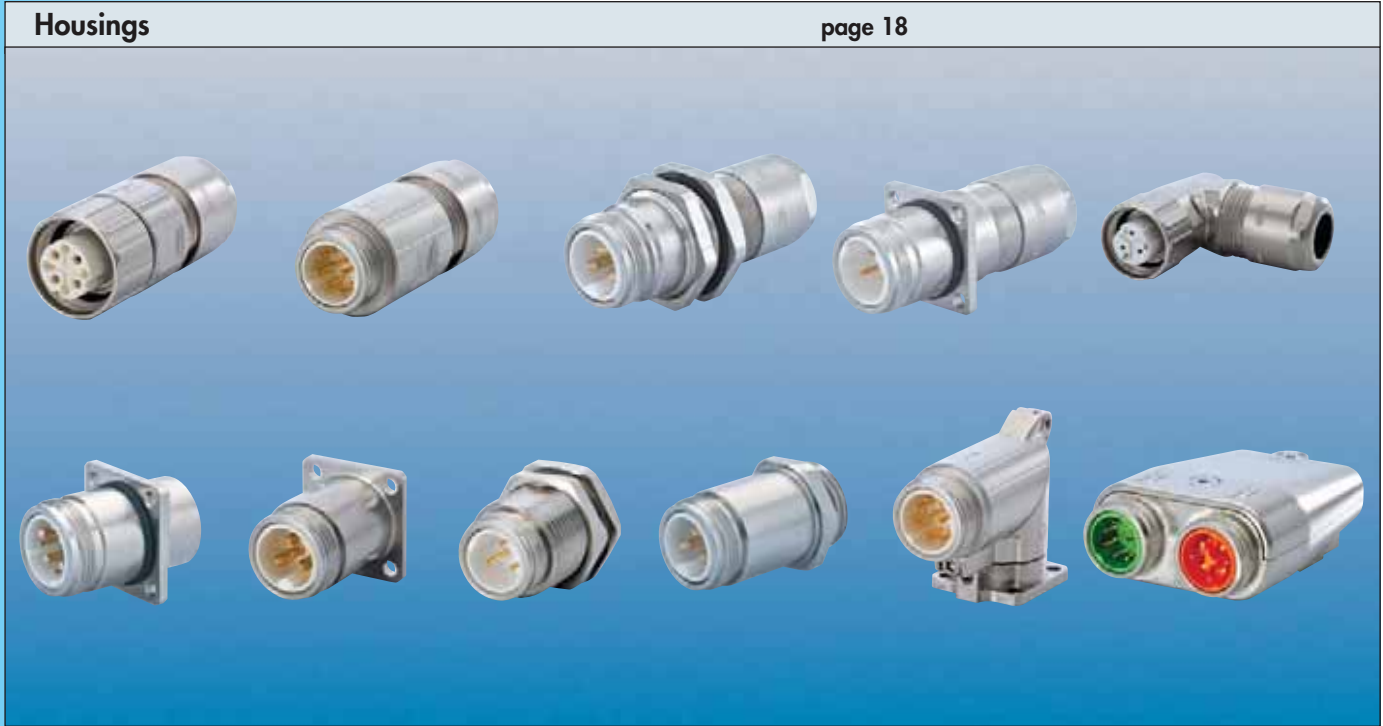

M 16 Control Signal Connectors

Mechanical Data	Materials and Technical Data
Housing	Copper-Zinc alloy Die Casting
Housing surface	Nickel plated other surface upon request
Inserts (for contacts)	Thermoplastic Polyamid PA 6 (Nylon 6/6), PBT Fire protection class V-0
Contacts	Brass Alloy
Contact surface at point of contact	Nickel and gold plated (0,25µm Au)
Minimum mating cycles	> 1000
Seals / O-Rings	Buna-N standard, optional Viton® (Viton is a registered trademark of DuPont)
Temperature range	-40° C – 125° C (-40 °F – 257 °F)
Type of contacts	Crimp, dip-solder (PCB)
Protection	IP 67 / IP 69K per EN 60 529 (connected), NEMA 4x
Cable diameter range	2 – 11 mm (.08 – .43")

Electrical Data						
Number of positions	3 (3x1 mm)	3 (3x2 mm)	4 + 3 + PE / 320V		4 + 3 + PE / 630V	
Number of contacts	3	3	4	4	4 4	
ContactØ [mm]	1	2	0,8	1,6	0,8 1,25	
AWG [mm ²]	0,14 – 1	0,5 – 2,5	0,08 – 0,34	0,34 – 1,5	0,08 – 0,34 0,34 – 1,5	
Nominal current ¹⁾ [A]	8	20	5	16	5 16	
Nominal voltage ²⁾ [V~] degree of protection 2 ⁴⁾	630	630	320	630	300 800	
Nominal voltage ²⁾ [V~] degree of protection 3 ⁴⁾	400	400	160	320	300 630	
Test voltage (Breakdown voltage) ³⁾ [V~]	2500	2500	1500	2500	1500 2500	
Insulation resistance [MΩ]	> 10 ¹⁰	> 10 ¹⁰	> 10 ¹⁰		> 10 ¹⁰	
Max. contact resistance [mΩ]	3	3	3		3 3	
Number of positions			10	12 + 3		18
Number of contacts			10	12	3	18
ContactØ [mm]			1	0,8	1,25	0,8
AWG [mm ²]			0,14 – 0,75	0,08 – 0,34	0,5 – 1,5	0,08 – 0,34
Nominal current ¹⁾ [A]			8	3	10	3
Nominal voltage ²⁾ [V~] degree of protection 2 ⁴⁾			230	60	160	60
Nominal voltage ²⁾ [V~] degree of protection 3 ⁴⁾			160	24	60	24
Test voltage (Breakdown voltage) ³⁾ [V~]			1500	1500	2500	1500
Insulation resistance [MΩ]			> 10 ⁶	> 10 ¹⁰		> 10 ¹⁰
Max. contact resistance [mΩ]			3	3	3	3

^{1), 2), 3), 4)} See Technical Information page 14

Connectors M 16 / Housing

Straight Connector, Female Thread	Cable-Ø	Part Number
	2 – 7 mm (.08 – .28").....	7.810.300.000
	5 – 9 mm (.20 – .35").....	7.810.400.000
	8 – 11 mm (.31 – .43").....	7.810.5000.00
	Contacts and inserts page 22 • Assembly instructions page 34 / 35	

Straight Connector, Male Thread	Cable-Ø	Part Number
	2 – 7 mm (.08 – .28").....	7.820.300.000
	5 – 9 mm (.20 – .35").....	7.820.400.000
	8 – 11 mm (.31 – .43").....	7.820.5000.00
	Contacts and inserts page 22 • Assembly instructions page 34 / 35	

Right Angle Connector, Female Thread	Cable-Ø	Part Number
	2 – 7 mm (.08 – .28").....	7.830.300.000
	5 – 9 mm (.20 – .35").....	7.830.400.000
	Contacts and inserts page 22 • Assembly instructions page 36	
	Assembly tool 7.010.900.125 is required	

Right Angle Connector with positioning	Cable-Ø	Part Number
	2 – 7 mm (.08 – .28").....	7.831.300.000
	5 – 9 mm (.20 – .35").....	7.831.400.000
	8 – 11 mm (.31 – .43").....	7.831.500.000
	Contacts and inserts page 22 • Assembly instructions page 37	

Connectors M 16 / Housing

Cable-Ø	Part Number	Panel Connector with built in Cable Strain Relief
Rear mounting, single hole mounted 2 – 7 mm (.08 – .28").....7.852.300.000 5 – 9 mm (.20 – .35").....7.852.400.000		
Including jam nut PG 11		
Contacts and inserts page 22 • Assembly instructions page 34 / 35		

Cable-Ø	Part Number	Panel Connector with built in Cable Strain Relief
Rear mounting, M2,5 x 4 single hole mounted 2 – 7 mm (.08 – .28").....7.847.300.000 5 – 9 mm (.20 – .35").....7.847.400.000		
Contacts and inserts page 22 • Assembly instructions page 34 / 35		

Type	Part Number	Panel Connector, Male Thread, Front Mounting
4 x holes Ø 2,7 mm (.11") ..7.840.000.000 Flange 20 x 20 mm		
4 x holes Ø 2,7 mm.....7.840.100.000 Flange 25 x 25 mm		
Contacts and inserts page 22 • Assembly instructions page 38		

Type	Part Number	Panel Connector, Male Thread, Front Mounting
Short version 4 x holes Ø 2,7 mm (.11") ..7.840.200.000 Flange 20 x 20 mm		
Contacts and inserts page 22 • Assembly instructions page 38		

Connectors M 16 / Housing

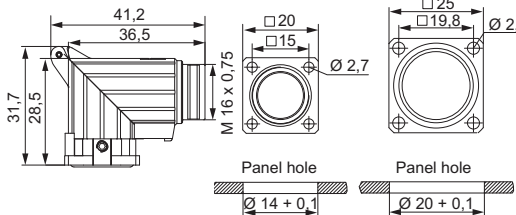
Right Angle Panel Connector, Male Thread, rotating		Type	Part Number
		300° rotating, locking screw at flange 4 x holes Ø 2,7 mm (.11") ...7.843.000.000 Flange 20 x 20 mm	
		4 x holes Ø 2,7 mm7.843.100.000 Flange 25 x 25 mm	Contacts and inserts page 22 • Assembly instructions page 39

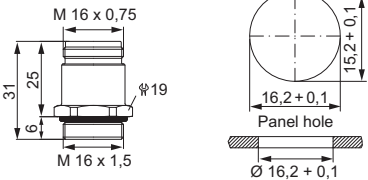
Panel Connector, Male Thread		Type	Part Number
		Front mounting, single hole mounted Thread M 16 x 1,57.842.000.000	
		Contacts and inserts page 22 • Assembly instructions page 38	

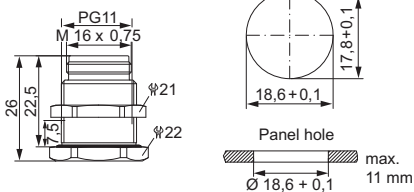
Panel Connector, Male Thread		Type	Part Number
		Rear mounting, single hole mounted Including jam nut7.850.000.000	
		Contacts and inserts page 22 • Assembly instructions page 38	

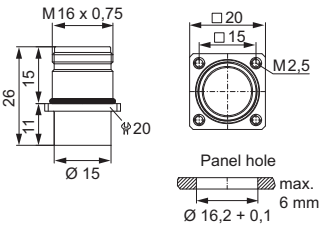
Panel Connector, Male Thread		Type	Part Number
		Rear mounting, 4 x thread M2,5 Flange 20 x 20 mm7.845.000.000	
		Contacts and inserts page 22 • Assembly instructions page 38	

Connectors M 16 / Housing



Type	Part Number	TWINTUS			
Flange 20 x 20 mm					
Uncoated	7.848.000.000				
Surface nickel plated	7.848.000.001				
Surface black conductive.....	7.848.000.00B				
Contacts and inserts page 22 • Assembly instructions page 33					

Type	Part Number	TWINTUS			
Flange 25 x 25 mm					
Uncoated	7.848.100.000				
Surface nickel plated	7.848.100.001				
Surface black conductive.....	7.848.100.00B				
Contacts and inserts page 22 • Assembly instructions page 33					



Type	Part Number	TWINTUS M 16 / M 12			
Flange 20 x 20 mm					
Uncoated	7.848.200.000				
Surface nickel plated	7.848.200.001				
Surface black conductive.....	7.848.200.00B				
Contacts and inserts page 22 • Assembly instructions page 33					

Type	Part Number	TWINTUS M 16 / M 12			
Flange 25 x 25 mm					
Uncoated	7.848.300.000				
Surface nickel plated	7.848.300.001				
Surface black conductive.....	7.848.300.00B				
Contacts and inserts page 22 • Assembly instructions page 33					

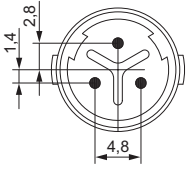
Connectors M 16 / Inserts / Pinouts

Inserts 3-pole (3 x 1 mm)	Type	Part Number	
		Pins	Sockets
 Insert pin mating view	Insert		
	without contacts	7.003.903.101	7.003.903.102
 Insert socket mating view	Insert with dip solder contacts		
	Length 10 mm	7.001.903.127	7.001.903.108
	Insert with dip solder contacts		
	Length 17 mm	7.001.903.137	7.001.903.118
	Required Contacts		
	3 x 1 mm	7.010.901.001	7.010.901.002 / 7.010.901.012

Contacts page 26-28

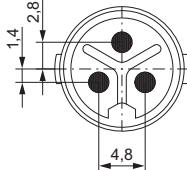
Inserts 3-pole (3 x 2 mm)	Type	Part Number	
		Pins	Sockets
 Insert pin mating view	Insert		
	without contacts	7.003.983.101	7.003.983.102
 Insert socket mating view	Insert with dip solder contacts		
	Length 10 mm	7.001.983.127	7.001.983.108
	Insert with dip solder contacts		
	Length 17 mm	7.001.983.137	7.001.983.118
	Required Contacts		
	3 x 2 mm	7.010.982.001	7.010.982.002

Contacts page 26-28

Connectors M 16 / Inserts / Pinouts

Type	Part Number	Part Number	Inserts 4+3+PE
	Pins	Sockets	
Insert without contacts	7.003.943.101	7.003.943.102	<p>Insert pin mating view</p>
Insert RAL 2003 (DESINA orange) without contacts	7.053.943.101	7.053.943.102	
Insert with dip solder contacts Length 10 mm	7.001.943.127	7.001.943.108	<p>Insert socket mating view</p>
Insert with dip solder contacts Length 17 mm	7.001.943.137	7.001.943.118	
Required Contacts			
4 x 0,8 mm	7.010.980.801	7.010.980.802	
4 x 1,6 mm	7.010.981.601	7.010.981.602	
Contacts page 26-28			

Type	Part Number	Part Number	Inserts 4+3+PE 630 V
	Pins	Sockets	
Insert without contacts	7.003.908.101	7.003.908.102	<p>Insert pin mating view</p>
Insert RAL 2003 (DESINA orange) without contacts	7.053.908.101	7.053.908.102	
Insert with dip solder contacts Length 10 mm ¹⁾	7.001.908.127	7.001.908.108	<p>Insert socket mating view</p>
Insert with dip solder contacts Length 17 mm ¹⁾	7.001.908.137	7.001.908.118	
Required Contacts			
4 x 0,8 mm	7.010.980.811	7.010.980.812	
4 x 1,25 mm	7.010.981.211	7.010.981.212	
Contacts page 26-28			

¹⁾ Under development

Connectors M 16 / Inserts / Pinouts

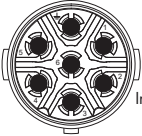
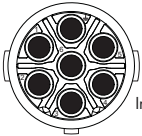
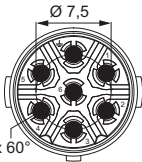
Inserts 6+PE	Type	Part Number	
		Pins	Sockets
 Insert pin mating view	Insert		
	without contacts	7.003.961.101	7.003.961.102
 Insert socket mating view	Insert RAL 2003 (DESINA orange)		
	without contacts	7.053.961.101	7.053.961.102
 Ø 7,5 6 x 60°	Insert with dip solder contacts		
	Length 10 mm	7.001.961.127	7.001.961.108
	Insert with dip solder contacts		
	Length 17 mm	7.001.961.137	7.001.961.118
	Required Contacts		
	7 x 1,25 mm	7.010.981.211	7.010.981.212

Contacts page 27-28

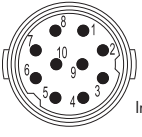
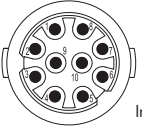
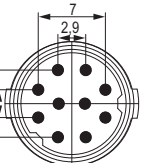
Inserts 10-pole	Type	Part Number	
		Pins	Sockets
 Insert pin mating view	Insert		
	without contacts	7.003.910.101	7.003.910.102
 Insert socket mating view	Insert RAL 6018 (DESINA green)		
	without contacts	7.053.910.101	7.053.910.102
 7 2,9	Insert with dip solder contacts		
	Length 10 mm	7.001.910.127	7.001.910.108
	Insert with dip solder contacts		
	Length 17 mm	7.001.910.137	7.001.910.118
	Required Contacts		
	10 x 1 mm	7.010.981.001	7.010.981.002

Contacts page 27-28

Connectors M 16 / Inserts / Pinouts

Type	Part Number	Part Number	Inserts 12+3-pole
	Pins	Sockets	
Insert without contacts	7.003.985.101	7.003.985.102	<p>Insert pin mating view</p>
Insert with dip solder contacts Length 10 mm	7.001.985.127	7.001.985.108	
Insert with dip solder contacts Length 17 mm	7.001.985.137	7.001.985.118	
Required Contacts			<p>Insert socket mating view</p>
12 x 0,8 mm	7.010.980.801	7.010.980.802	
3 x 1,25 mm	7.010.981.201	7.010.981.202	<p>Ø 9 Ø 3,6 3 x 120° 12 x 30°</p>
Contacts page 27-28			







Type	Part Number	Part Number	Inserts 18-pole
	Pins	Sockets	
Insert without contacts	7.003.988.101	7.003.988.102	<p>Insert pin mating view</p>
Insert RAL 6018 (DESINA green) without contacts	7.053.988.101	7.053.988.102	
Insert with dip solder contacts Length 10 mm	7.001.988.127	7.001.988.108	<p>Insert socket mating view</p>
Insert with dip solder contacts Length 17 mm	7.001.988.137	7.001.988.118	
Required Contacts			<p>2,25 1,56 0,56 4,87 3,91 2,17 12 x 120° Ø 9</p>
18 x 0,8 mm	7.010.980.801	7.010.980.802	
Contacts page 27-28			

Connectors M 16 / Inserts / Pinouts

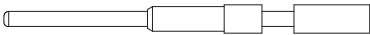
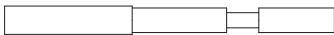
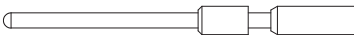
Inserts M 12 for TWINTUS M 16 / M 12 8-pole	Type	Part Number
 <p data-bbox="300 607 451 629">insert pin mating view</p>	<p data-bbox="946 472 1217 495">Pins</p> <p data-bbox="946 504 1185 526">Insert with solder contacts</p>	<p data-bbox="1249 472 1297 495">Pins</p> <p data-bbox="1249 504 1457 526">A712-7001908103</p>



Inserts M 12 for TWINTUS M 16 / M 12 12-pole	Type	Part Number
 <p data-bbox="300 943 451 965">insert pin mating view</p>	<p data-bbox="946 808 1217 831">Pins</p> <p data-bbox="946 840 1185 862">Insert with solder contacts</p>	<p data-bbox="1249 808 1297 831">Pins</p> <p data-bbox="1249 840 1457 862">A712-7001912103</p>

Connectors M 16 / Contacts

Type	Crimp Range	Part Number	Contacts
Crimp pin 0,8 mm, machined.....	0,08 – 0,34 mm ² (AWG 28 – 22)	7.010.980.801	
Crimp socket 0,8 mm, machined.....	0,08 – 0,34 mm ² (AWG 28 – 22)	7.010.980.802	
Crimp pin 0,8 mm, machined.....	0,08 – 0,34 mm ² (AWG 28 – 22)	7.010.980.811	
Crimp socket 0,8 mm, machined.....	0,08 – 0,34 mm ² (AWG 28 – 22)	7.010.980.812	
Crimp pin 1 mm, machined.....	0,08 – 0,75 mm ² (AWG 28 – 18)	7.010.981.001	
Crimp socket 1 mm, machined.....	0,08 – 0,75 mm ² (AWG 28 – 18)	7.010.981.002	
Crimp pin 1 mm, machined.....	0,14 – 1 mm ² (AWG 26 – 17)	7.010.901.001	
Crimp socket 1 mm, machined.....	0,08 – 0,56 mm ² (AWG 28 – 20)	7.010.901.012	
Crimp socket 1 mm, machined.....	0,34 – 1 mm ² (AWG 22 – 17)	7.010.901.002	

Please see assembly instructions on page 40

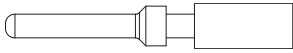
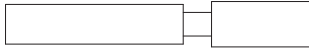
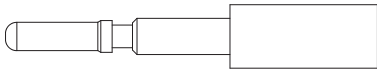
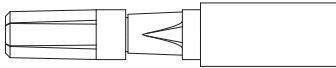
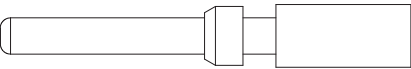
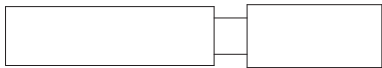
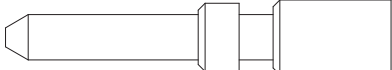
Connectors M 16 / Contacts

Contacts	Type	Crimp Range	Part Number
	Crimp pin 1,25 mm, machined.....	0,5 – 1,5 mm ² (AWG 20 – 16).....	7.010.981.201
	Crimp socket 1,25 mm, machined.....	0,5 – 1,5 mm ² (AWG 20 – 16).....	7.010.981.202
	Crimp pin 1,25 mm, machined.....	0,5 – 1,5 mm ² (AWG 20 – 16).....	7.010.981.211
	Crimp socket 1,25 mm, machined.....	0,5 – 1,5 mm ² (AWG 20 – 16).....	7.010.981.212
	Crimp pin 1,6 mm, machined.....	0,34 – 1,5 mm ² (AWG 22 – 16) ..	7.010.981.601
	Crimp socket 1,6 mm, machined.....	0,34 – 1,5 mm ² (AWG 22 – 16) ..	7.010.981.602
	Crimp pin 2 mm, machined.....	1,0 – 2,5 mm ² (AWG 17 – 14).....	7.010.982.001
	Crimp socket 2 mm, machined.....	1,0 – 2,5 mm ² (AWG 17 – 14) ..	7.010.982.002

Crimp Tool Settings see page 31 / 32
Please see assembly instructions on page 40

Connectors M 16 / Accessories

Type	Part Number	Accessories
Plastic protective cap for connectors with male thread7.000.980.161 for connectors with female thread7.000.980.162		
Brass protective cap for connectors with female thread7.010.900.163		
Brass protective cap for connectors with male thread7.010.900.162		
Brass protective cap with chain for connectors with female threadLength 70 mm7.010.9S0.705		
Brass protective cap with chain for connectors with male threadLength 70 mm7.010.9S0.704		
Assembly tool for Right Angle Connector M 167.010.900.125		

Connectors M 16 / Accessories

Accessories	Type	Part Number
	Crimp tool for manual crimping of machined crimp contacts for signal connectors M 16 and M 23	7.000.900.904
See page 84 for crimp tool instructions		
	Adaptor flange for Straight Connectors	7.010.900.135
	Conduit adaptor	DN 107.010.900.200 Snapflex 16.....7.010.900.201 DN 127.010.900.202 Snapflex 16.....7.010.900.203
	EMC-sheet for TWINTUS Flange 20 x 20 for TWINTUS Flange 25 x 25	7.040.848.101 7.040.848.102
	Plastic protective cap for TWINTUS TWINTUS M 16 TWINTUS M 16 / M 12	7.000.848.101 7.000.848.102

Please see assembly instructions on page 34

Crimp Tool for Connectors M 16

Crimp Tool Setting for HUMMEL Crimp Contacts (Crimp Tool 7.000.900.904)

Part Number	Crimp Contact	Cross Section (mm ²)	AWG	Crimp Tool Setting mm	Locator Setting
7.010.980.801	Crimp pin 0,8 mm	0,08	AWG 28	0,57	10
		0,14	AWG 26	0,60	
		0,25	AWG 24	0,64	
		0,34	AWG 22	0,73	
7.010.980.802	Crimp socket 0,8 mm	0,08	AWG 28	0,57	10
		0,14	AWG 26	0,60	
		0,25	AWG 24	0,64	
		0,34	AWG 22	0,73	
7.010.980.811	Crimp pin 0,8 mm	0,08	AWG 28	0,57	B7
		0,14	AWG 26	0,60	
		0,25	AWG 24	0,64	
		0,34	AWG 22	0,73	
7.010.980.812	Crimp socket 0,8 mm	0,08	AWG 28	0,57	B8
		0,14	AWG 26	0,60	
		0,25	AWG 24	0,64	
		0,34	AWG 22	0,73	
7.010.981.001	Crimp pin 1 mm	0,08	AWG 28	0,60	7
		0,14	AWG 26	0,65	
		0,25	AWG 24	0,67	
		0,34	AWG 22	0,71	
		0,56	AWG 20	0,75	
		0,75	AWG 18	0,82	
7.010.981.002	Crimp socket 1 mm	0,08	AWG 28	0,60	8
		0,14	AWG 26	0,63	
		0,25	AWG 24	0,66	
		0,34	AWG 22	0,69	
		0,56	AWG 20	0,75	
		0,75	AWG 18	0,83	
7.010.901.001	Crimp pin 1 mm	0,14	AWG 26	0,70	1
		0,25	AWG 24	0,76	
		0,34	AWG 22	0,82	
		0,50	AWG 20	0,90	
		0,75	AWG 18	1,00	
		1,0	AWG 17	1,10	
7.010.901.012	Crimp socket 1 mm (0,08-0,56 mm ²)	0,08	AWG 28	0,75	2
		0,14	AWG 26	0,78	
		0,25	AWG 24	0,82	
		0,34	AWG 22	0,86	
		0,56	AWG 20	0,90	

These values are only guidelines and actual conductor cross sections depend on manufacturer tolerances.

See page 40 for crimp tool instructions

Crimp Tool for Connectors M 16

Crimp Tool Setting for HUMMEL Crimp Contacts (Crimp Tool 7.000.900.904)					
Part Number	Crimp Contact	Cross Section (mm ²)	AWG	Crimp Tool Setting mm	Locator Setting
7.010.901.002	Crimp socket 1 mm (0,34 – 1 mm ²)	0,34	AWG 22	0,77	2
		0,56	AWG 20	0,82	
		0,75	AWG 18	0,88	
		1,0	AWG 17	0,95	
7.010.981.201	Crimp pin 1,25 mm	0,5	AWG 20	0,70	2
		0,75	AWG 18	0,73	
		1,0	AWG 17	0,79	
		1,5	AWG 16	0,88	
7.010.981.202	Crimp socket 1,25 mm	0,5	AWG 20	0,70	2
		0,75	AWG 18	0,73	
		1,0	AWG 17	0,79	
		1,5	AWG 16	0,88	
7.010.981.211	Crimp pin 1,25 mm	0,34	AWG 22	0,80	B9
		0,5	AWG 20	0,84	
		0,75	AWG 18	0,90	
		1,0	AWG 17	1,00	
		1,5	AWG 16	1,10	
7.010.981.212	Crimp socket 1,25 mm	0,34	AWG 22	0,80	B10
		0,5	AWG 20	0,84	
		0,75	AWG 18	0,90	
		1,0	AWG 17	1,00	
		1,5	AWG 16	1,10	
7.010.981.601	Crimp pin 1,6 mm	0,34	AWG 22	0,80	6
		0,56	AWG 20	0,84	
		0,75	AWG 18	0,90	
		1,0	AWG 17	1,00	
		1,5	AWG 16	1,10	
7.010.981.602	Crimp socket 1,6 mm	0,34	AWG 22	0,83	9
		0,56	AWG 20	0,90	
		0,75	AWG 18	0,97	
		1,0	AWG 17	1,02	
		1,5	AWG 16	1,10	
7.010.982.002	Crimp socket 2 mm	1,0	AWG 17	1,35	4
		1,5	AWG 16	1,45	
		2,5	AWG 14	1,60	
7.010.982.001	Crimp pin 2 mm	1,0	AWG 17	1,35	5
		1,5	AWG 16	1,45	
		2,5	AWG 14	1,60	

These values are only guidelines and actual conductor cross sections depend on manufacturer tolerances.

See page 40 for crimp tool instructions

Connectors M 16 / Assembly Instructions

TWINTUS

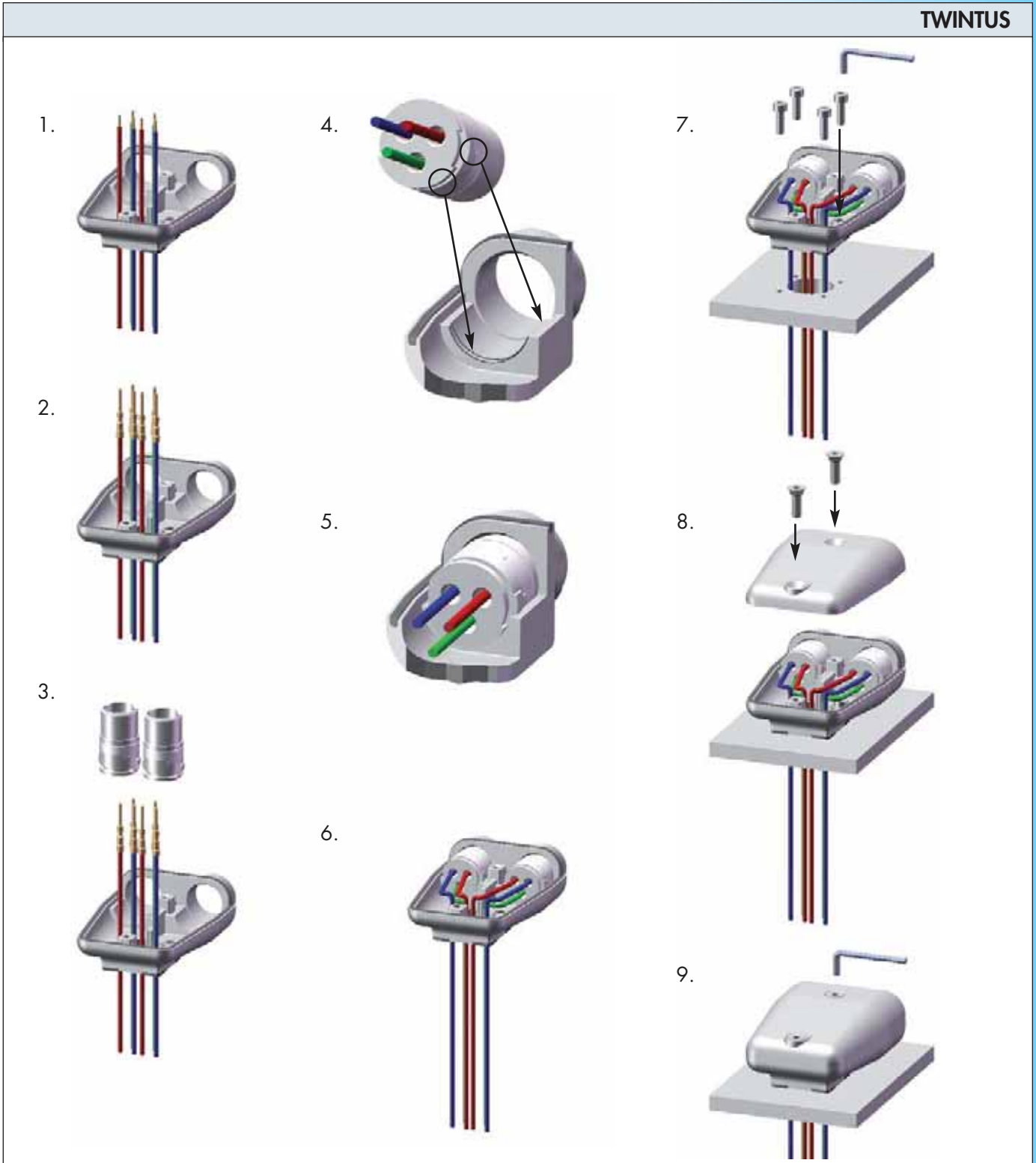

Connectors M 16 / Assembly Instructions

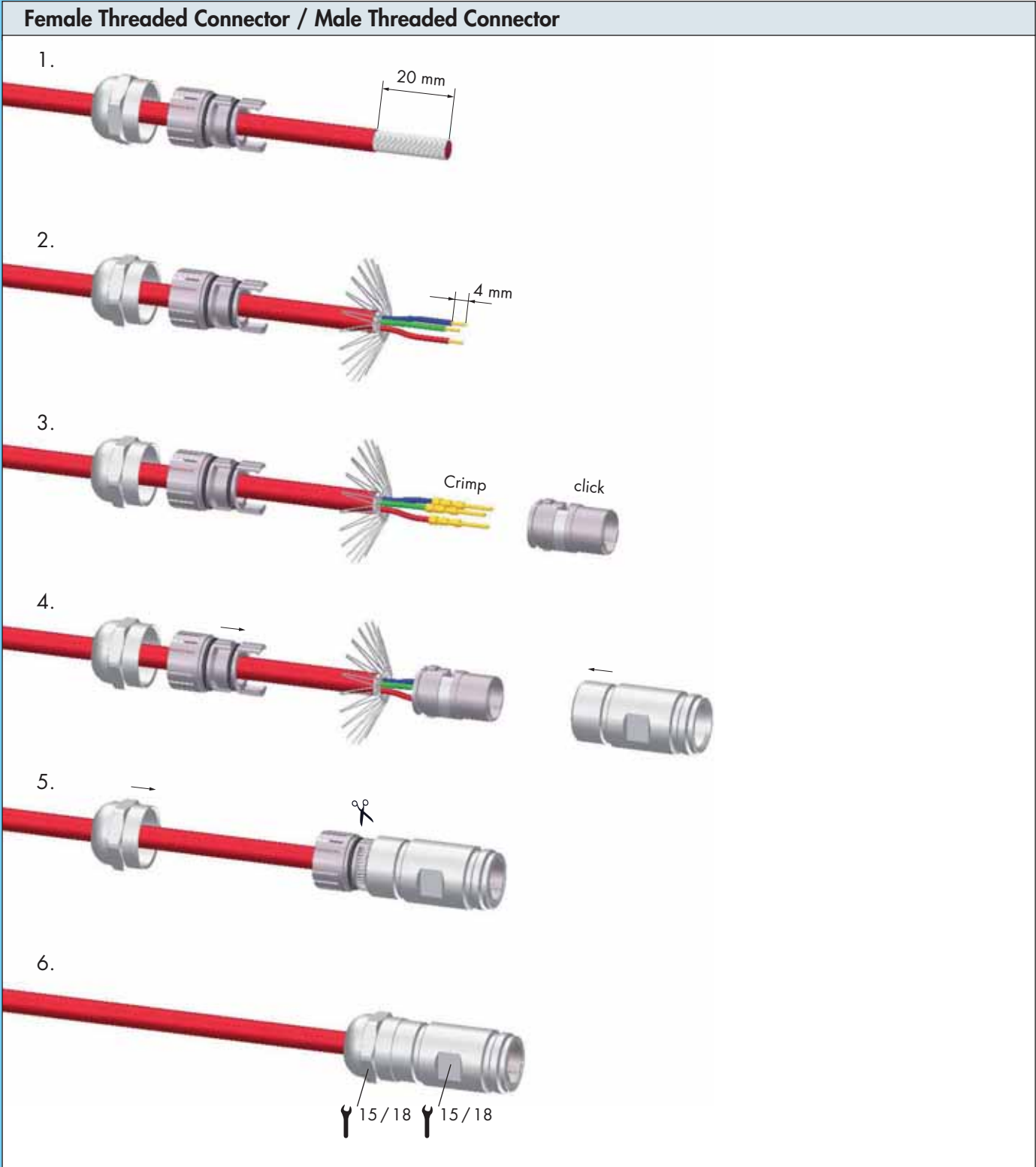

Connectors M 16 / Assembly Instructions

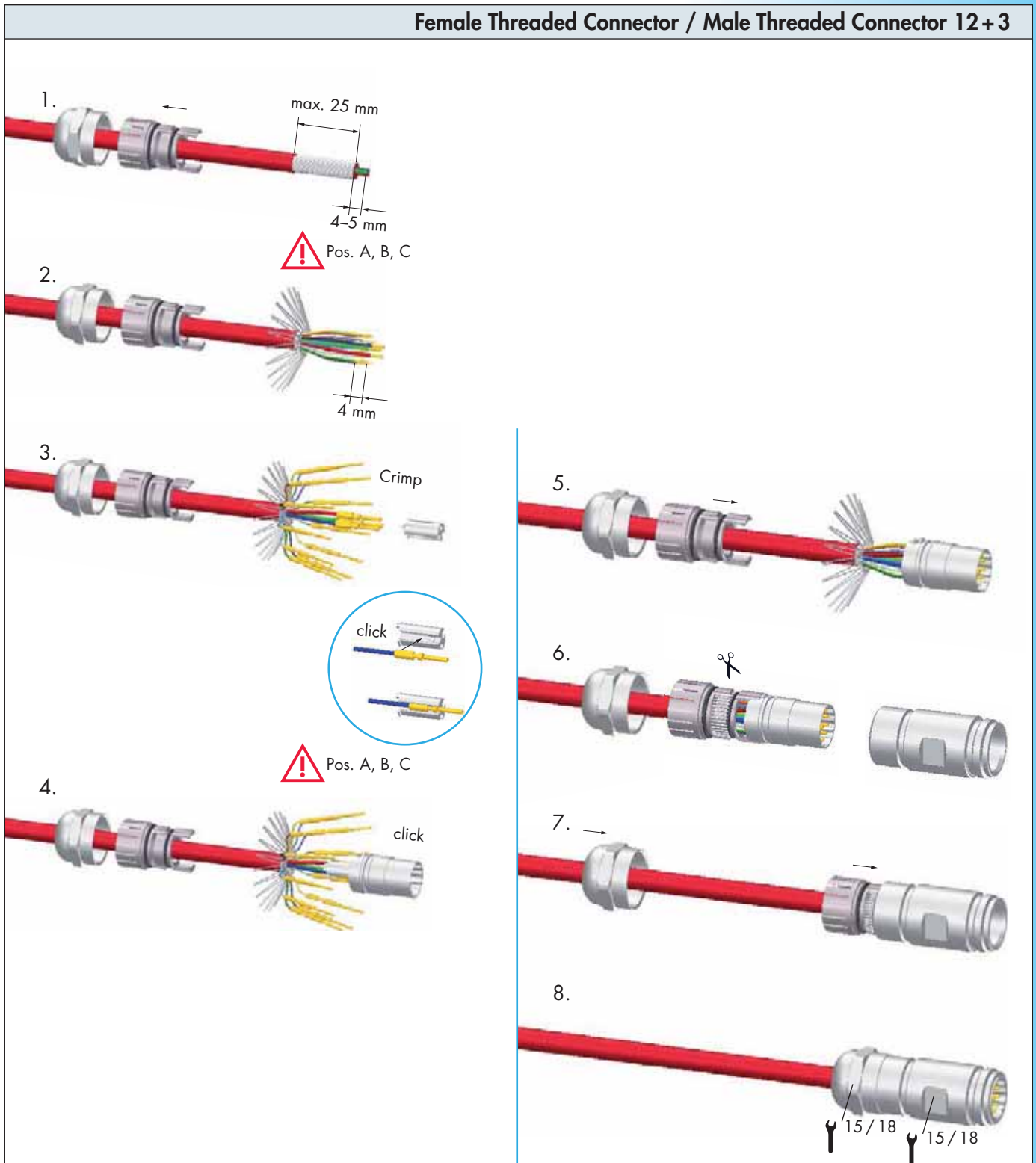

Connectors M 16 / Assembly Instructions

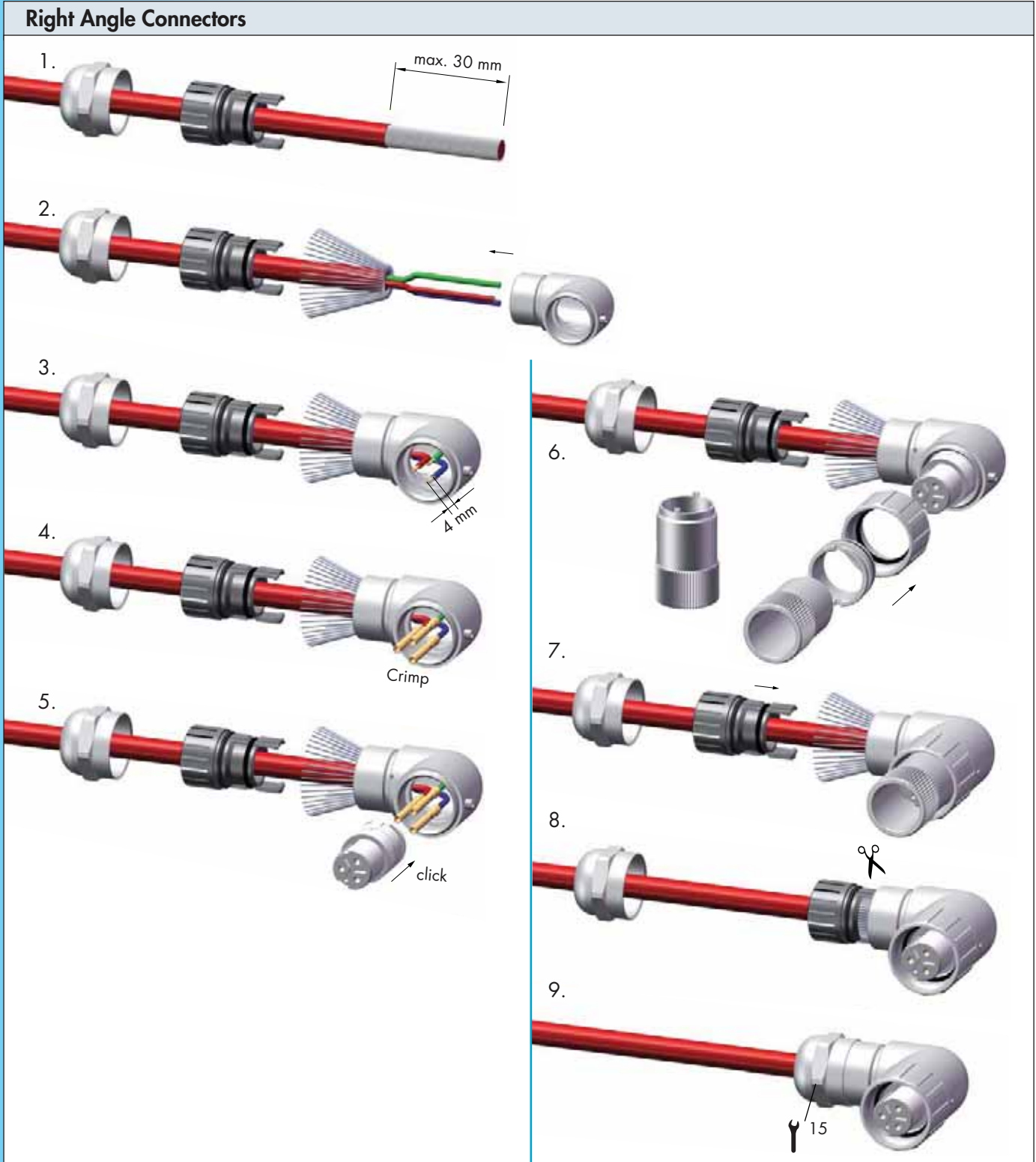

Connectors M 16 / Assembly Instructions

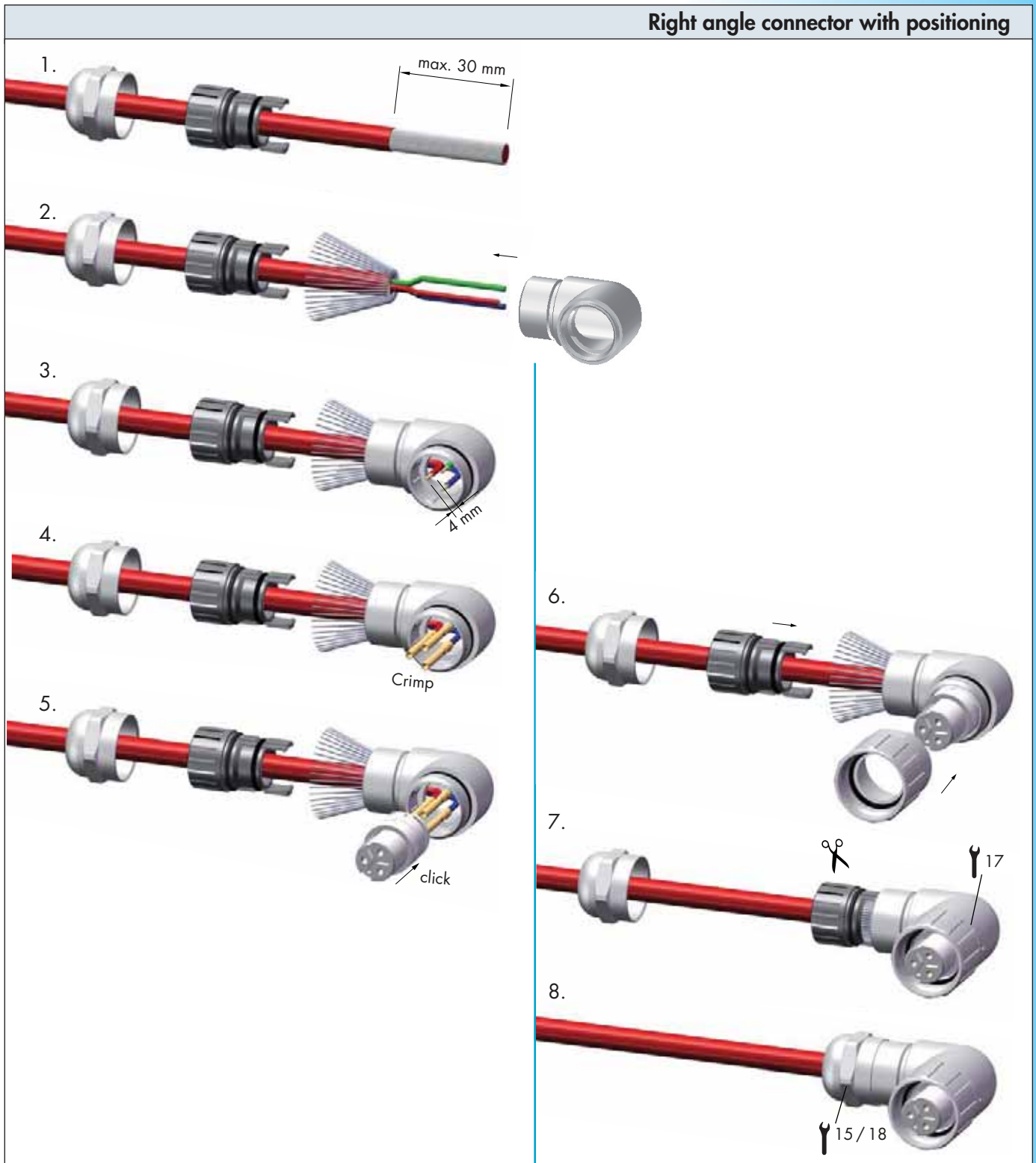

Connectors M 16 / Assembly Instructions

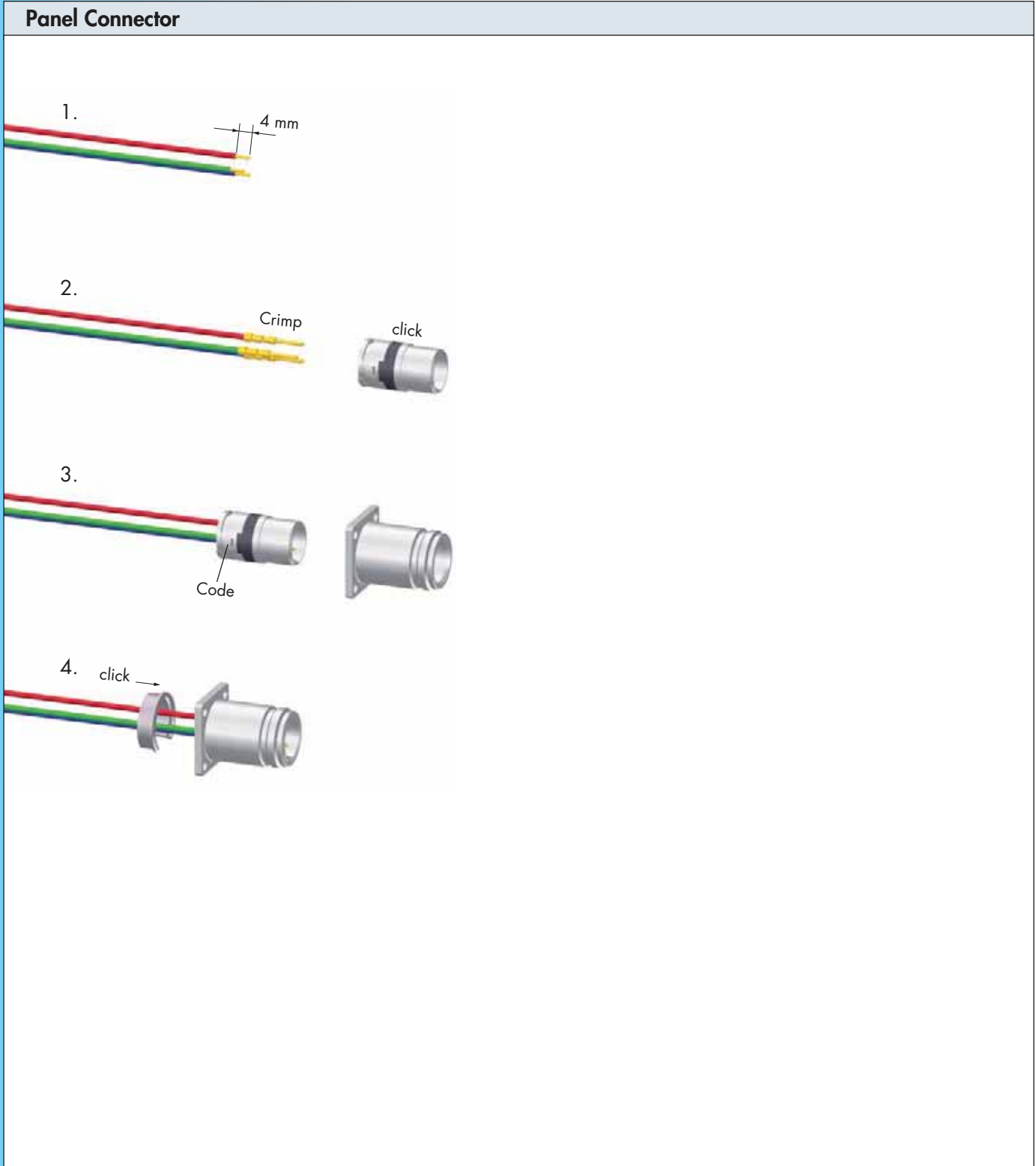

Connectors M 16 / Assembly Instructions

Right Angle Panel Connector

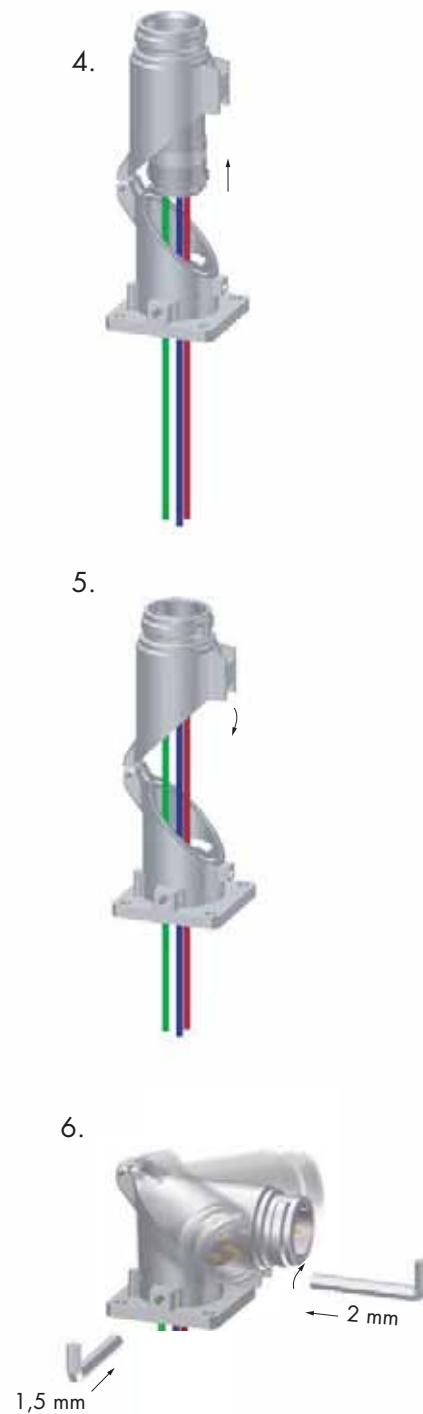
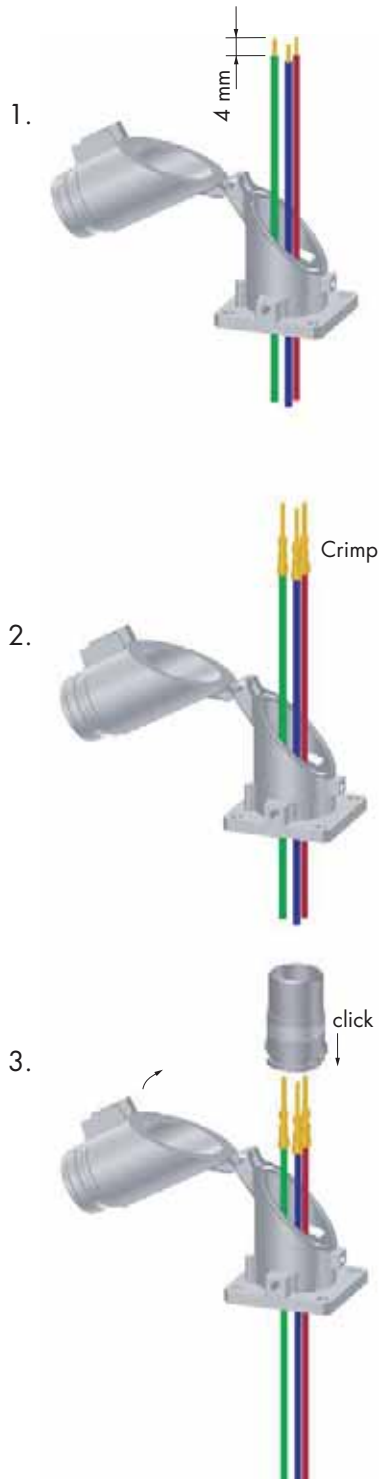

Crimping, Assembly and Disassembly of Contacts

Crimping, Assembly and Disassembly of Contacts

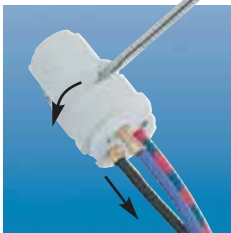

Crimping

- Remove conductor insulation 4 mm (.16") max.
- Select appropriate Crimp tool setting (see page 31 - 32)
- Push crimp contact into opening of crimping tool
- Insert stripped wire into the funnel shaped end of the crimp contact
- Squeeze handles of crimping tool together connect contact to wire

Assembly

- Remove crimped assembly and pull on wire to test connection
- Push into desired position of insert

Disassembly of Contacts from Insert

A small screwdriver is needed to remove the contacts from the insert.

- Release the white ring by a screwdriver out of the insert
- Move the misplaced contacts out of the insert
- Enter the ring back into the insert
- Push the contacts back into insert

Shielding

- Assemble strain relief insert with insert
- Fold stranding of the shield back over the first O-Ring of the strain relief insert
- Cut back the overextending braid

 The stranding of the shield is not allowed to touch the second O-Ring. Otherwise the assembly may not be proof.

M 23 Fast Ethernet PoE



Product Overview

Housings	page 44
	

Inserts	page 46
	

Accessories	page 51
	

M 23 Fast Ethernet PoE Connectors

Mechanical Data	Materials and Technical Data
Housing	Copper-Zinc alloy Die Casting
Housing surface	Nickel plated
Inserts (for contacts)	PBT UL-94 V0, PA6
Contacts	Brass Alloy
Contact surface at point of contact	Nickel and gold plated (0,25µm Au)
Minimum mating cycles	> 1000
Seals / O-Rings	Perbunan NBR (Standard)
Temperature range	-40° C – 125° C (-40 °F – 257 °F)
Type of contacts	Crimp, dip-solder (PCB)
Protection	IP 67 per EN 60 529 (connected), NEMA 4x
Cable diameter range	11 – 17 mm (.43" – .67")

Electrical Data		
Number of positions	20 (4x2 + 12)	
Number of contacts	4x2	12
ContactØ [mm]	0,6	1
AWG [mm ²]	0,08 – 0,34	0,14 – 1 / 1,5
Nominal current ¹⁾ [A]	2	8 ¹⁾
Nominal voltage ²⁾ [V~] degree of protection 2 ⁴⁾	160	320
Nominal voltage ²⁾ [V~] degree of protection 3 ⁴⁾	60	160
Test voltage (Breakdown voltage) ³⁾ [V~]	500	1500
Insulation resistance [MΩ]	> 10 ⁶	> 10 ⁶
Max. contact resistance [mΩ]	3	3
Impedance [Ω] (at 100MHz)	100	-

^{1), 2), 3), 4)} See Technical Information page 14 ¹⁾ for single contacts even 10 A possible

M 23 Fast Ethernet PoE Connectors / Housing

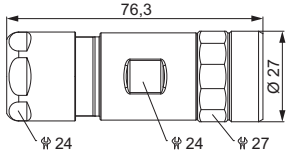

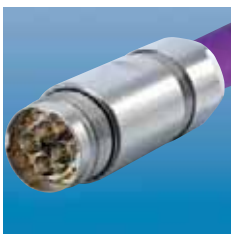
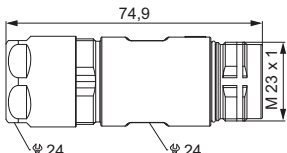
Straight Female Connector	Cable-Ø	Part Number
 	11-17 mm (.43 – .67")7.108.600.000
Inserts page 46 • Assembly instructions page 48		

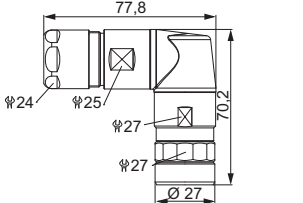
Straight Connector, Male Thread	Cable-Ø	Part Number
 	11-17 mm (.43 – .67")7.208.600.000
Inserts page 46 • Assembly instructions page 48		

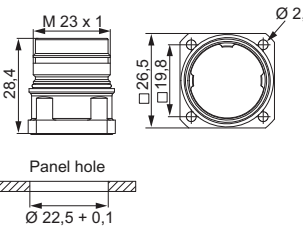
Right Angle Connector, Female Thread, rotating	Cable-Ø	Part Number
 	11-17 mm (.43 – .67")7.308.600.000
Inserts page 46 • Assembly instructions page 50		



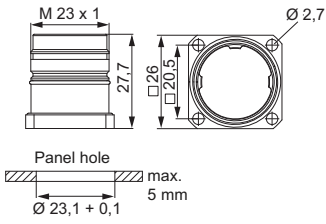

Panel Connector, Male Thread, Front Mounting	Type	Part Number
 	4 x holes Ø 2,7 mm (.11") Flange 26 x 26 mm7.408.000.000
Inserts page 46 • Assembly instructions page 49		

M 23 Fast Ethernet PoE Connectors / Housing

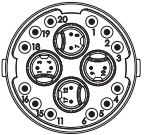
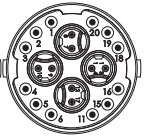
Type	Part Number	Panel Connector, Rear Mounting
<p>4 x holes \varnothing 2,7 mm (.11") ..7.468.000.000 Flange 26 x 26 mm</p>	 <p>Panel hole \varnothing 23,1 + 0,1 max. 5 mm</p>	
<p>Inserts page 46 • Assembly instructions page 49</p>		

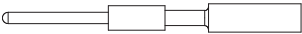
M 23 Fast Ethernet PoE Connectors / Inserts / Pinouts / Contacts

Inserts (4 x 2) + 12	Type	Part Number	
		Pins	Sockets
 <p>Insert pin mating view</p>	Insert		
	without contacts	7.003.920.101	7.003.920.102
	Insert with dip solder contacts	7.001.920.107	7.001.920.108
 <p>Insert socket mating view</p>	Required Contacts		
	8 x 0,6	7.010.980.641	7.010.980.602
	12 x 1	7.010.901.045	7.010.901.002
		7.010.901.049	7.010.901.012
			7.010.901.022
			7.010.901.046

Contacts	Type	Part Number	Part Number
	Crimp pin 0,6 mm, machined....	0,08 – 0,34 mm ²	7.010.980.641
	Crimp socket 0,6 mm, machined....	0,08 – 0,34 mm ²	7.010.980.602
	Crimp pin 1 mm, machined.....	0,14 – 1 mm ²	7.010.901.049
		0,75 – 1,5 mm ²	7.010.901.045
	Crimp socket 1 mm, machined...	0,08 – 0,56 mm ²	7.010.901.012
		0,34 – 1 mm ²	7.010.901.002
		0,75 – 1,5 mm ²	7.010.901.022
		1 – 1,75 mm ²	7.010.901.046

Please see assembly instructions on page 47

Crimp Tool Settings for crimp contacts M23 Fast Ethernet PoE

Crimp Tool Settings for HUMMEL Crimp Contacts (Crimp Tool 7.000.900.907)					
Part Number	Crimp Contact	Cross Section (mm ²)	AWG	Crimp Tool Setting mm	Locator Setting
7.010.980.641	Crimp pin 0,6 mm (0,08 – 0,34 mm ²)	0,08	AWG 28	0,57	B 1
		0,14	AWG 26	0,60	
		0,25	AWG 24	0,64	
		0,34	AWG 22	0,73	
7.010.980.602	Crimp socket 0,6 mm (0,08 – 0,34 mm ²)	0,08	AWG 28	0,57	B 2
		0,14	AWG 26	0,60	
		0,25	AWG 24	0,64	
		0,34	AWG 22	0,73	
7.010.901.049	Crimp pin 1 mm (0,14 – 1,0 mm ²)	0,14	AWG 26	0,70	B 3
		0,25	AWG 24	0,76	
		0,34	AWG 22	0,82	
		0,56	AWG 20	0,90	
		0,75	AWG 18	1,00	
		1,00	AWG 17	1,10	
7.010.901.045	Crimp pin 1 mm (0,75 – 1,5 mm ²)	0,75	AWG 18	0,80	B 5
		1,00	AWG 17	0,85	
		1,50	AWG 16	0,95	
7.010.901.012	Crimp socket 1 mm (0,08 – 0,56 mm ²)	0,08	AWG 28	0,75	B 4
		0,14	AWG 26	0,78	
		0,25	AWG 24	0,82	
		0,34	AWG 22	0,88	
		0,56	AWG 20	0,90	
7.010.901.002	Crimp socket 1 mm (0,34– 1,0 mm ²)	0,34	AWG 22	0,77	B 4
		0,56	AWG 20	0,82	
		0,75	AWG 18	0,88	
		1,00	AWG 17	0,95	
7.010.901.022	Crimp socket 1 mm (0,75 – 1,5 mm ²)	0,75	AWG 18	0,80	B 4
		1,00	AWG 17	0,86	
		1,50	AWG 16	0,95	
7.010.901.046	Crimp socket 1 mm (1 – 1,75 mm ²)	1,00	AWG 17	0,85	B 6
		1,50	AWG 16	0,95	
		1,75	AWG 15	1,00	

These values are only guidelines and actual conductor cross sections depend on manufacturer tolerances.

M23 Fast Ethernet PoE Connectors / Assembly Instructions

Straight Connector Male / Female Thread

1.

x	Pins = 41 mm Sockets = 37 mm
---	---------------------------------

2.

y	Pins = 7 mm Sockets = 0 mm
---	-------------------------------

3.

z	Pins = 10 mm Sockets = 7 mm
---	--------------------------------

4. max. 4,5 mm

5. max. 4 mm

6. Crimp

7. Crimp
click

8. Code
click

9. Crimp
7.000.900.906

10. Code + Position

11. Code

12. click

13. click

14. Code

15. ✂

16. 27 24

M 23 Fast Ethernet PoE Connectors / Assembly Instructions

Panel Connector

The diagram illustrates the 12 steps of assembling the M 23 Fast Ethernet PoE Panel Connector:

- Strip the cable jacket by a length x (max. 4,5 mm). A warning triangle indicates that pins must be 10 mm and sockets must be 7 mm.
- Strip the individual conductors by a length of max. 4 mm.
- Crimp the conductors onto the inner conductors of the cable jacket.
- Crimp the conductors onto the individual conductors of the cable jacket.
- Click the inner conductors into the connector housing.
- Click the individual conductors into the connector housing.
- Crimp the conductors onto the individual conductors of the cable jacket using a crimping tool (7.000.900.906).
- Click the inner conductors into the connector housing.
- Click the individual conductors into the connector housing.
- Click the conductors into the connector housing.
- Click the conductors into the connector housing.
- Click the conductors into the connector housing.

M23 Fast Ethernet PoE Connectors / Assembly Instructions

Right Angle Connector

1.

2.

3.

x	Pins = 7 mm Sockets = 0 mm
y	Pins = 10 mm Sockets = 7 mm

4.

5. Crimp

6. Crimp

7. click

8. click
Code

9. 7.000.900.906

10. Code + Position

11. Code

12. Code

13. click

14. Code

15. 27

16. ✂

17. 27 24

M 23 Fast Ethernet PoE Connectors / Accessories

Type	Part Number	Accessories
Plastic protective cap for connectors with male thread	7.000.900.101	
for connectors with female thread	7.000.900.102	
Brass protective cap for connectors with female thread	7.010.900.183	
Brass protective cap with chain for connectors with female thread		
Length 70 mm	7.010.9S0.783	
Length 100 mm	7.010.9S1.083	
Brass protective cap for connectors with male thread	7.010.908.102	
Brass protective cap with chain for connectors with male thread		
Length 70 mm	7.010.9S0.702	
Length 100 mm	7.010.9S1.002	
Conduit adaptor		
Snapflex 16	7.010.900.204	
DN 12	7.010.900.205	
Snapflex 20	7.010.900.206	
DN 14	7.010.900.207	
Snapflex 25	7.010.900.208	
DN 17	7.010.900.209	
Adaptor flange for Straight Connectors	7.010.900.128	

M 23 Fast Ethernet PoE Connectors / Accessories

Accessories	Type	Part Number
	Adapter flange for moulded connectors	7.010.900.139
	Multi-Bus adapter wired through I:I (excentric) Multi-Bus I, Female Thread, Sockets 17pole Multi-Bus II, Male Thread, Pins	7.010.900.143 Multi-Bus I, Female Thread, Pins, 17pole Multi-Bus II, Male Thread, Sockets
	Control Cabinet adapter for Multibus II - AIDA Rear Mounting, central locking	7.010.900.145
	I/O adapter module to scan or feed signals Rear Mounting, central locking	7.010.900.146
	Manual Crimp tool for EMC sleeves M 23 Fast Ethernet PoE ...	7.000.900.906
	Manual Crimp tool for turned contacts M 23 Fast Ethernet PoE	7.000.900.907

Connectors M 23 RJ 45



Housings

page 56



Accessories

page 59





M 23 RJ45 Control Signal Connectors

Technical Data	Materials and Technical Data
Housing	Brass Alloy, Die Cast
Housing Surface	Nickel Plated
Inserts (for contacts)	PBT UL-94 V0, PA 6
Contacts	Brass Alloy
Contact Surface at point of contact	Depends on RJ 45 type used
Seals / O-Rings	NBR / FKM (Viton)
Temperature Range	Depends on RJ 45 type used
Degree of Protection	IP 67 / IP 69K per EN 60529 (mated)
Cable diameter range	3 - 7 / 7 - 12 / 11 - 17mm
Number of Positions	4 / 6 / 8 poles, optional 4 + 2 / 6 + 2 / 8 + 2
Nominal Current ¹⁾ [A]	Depends on RJ 45 type used
Nominal Voltage ²⁾ [V~]	Depends on RJ 45 type used
Test Voltage [V~]	Depends on RJ 45 type used
Insulation Resistance [MΩ]	Depends on RJ 45 type used
Max. Crossover Resistance [mΩ]	Depends on RJ 45 type used
Max. Data Rate	Depends on RJ 45 type used

^{1), 2)} See Technical Information page 14

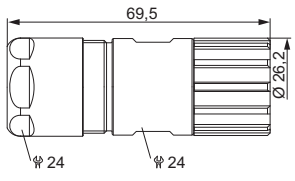
Connectors M 23 RJ 45 / Housing

Straight Connector Female Thread		Cable-Ø	Part Number
		3 – 7 mm (.12 - .28")7.R10.400.000	Connector with insert for patch cable
		Suitable patch cable and plugs can be recommended	
Assembly instructions page 61			

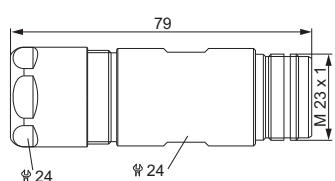
Straight Connector Male Thread		Cable-Ø	Part Number
		3 – 7 mm (.12 - .28")7.R20.408.000	Incl. 8 poles coupler, fully occupied
		Assembly instructions page 62	

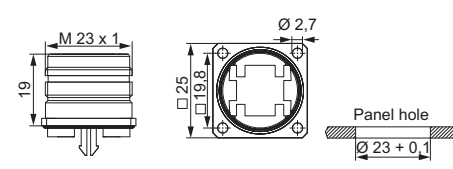
Panel Connector Front Mount, dip solder insert		Type	Part Number
		4 holes 2.7 mm, Flange7.R40.008.000	Incl. 8 poles dip solder insert
		4 holes 2.7 mm, Flange7.R40.082.000	
		Incl. 8 + 2 poles dip solder insert	

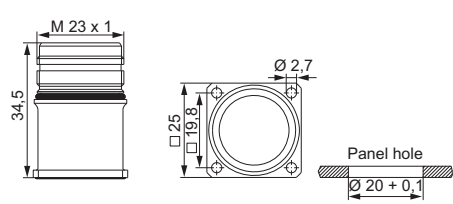
Panel Connector, Front Mount		Type	Part Number
		with vibration protection	4 holes 2.7 mm, Flange7.R41.008.000
		Incl. 8 poles coupler, fully occupied	

Connectors M 23 RJ 45 / Housing

Type	Part Number	Single Hole Panel Connector
Front Mount M 20 x 1,5 thread7.R42.008.000 Incl. 8 poles coupler, fully occupied Optional: Gasket M 20 x 1,5, Locking Nut		

Type	Part Number	Single Hole Panel Connector
Rear Mount M 25 x 1,5 thread7.R50.008.000 Incl. 8 poles coupler, fully occupied M 25 x 1,5 Locking Nut included		

Type	Part Number	Right Angle Panel Connector, Male Thread
300° rotating, locking screw at flange 4 holes 2.7 mm, Flange7.R43.008.000 Incl. 8 poles coupler, fully occupied Optional: Gasket Simple installation with M 2.5 screws		

Type	Part Number	Panel Connector Rear Mount, dip solder insert
with vibration protection 4x M 3 thread, Flange7.R45.008.000 Incl. 8 poles dip solder insert 4x M 3 thread, Flange7.R45.082.000 Incl. 8 + 2 poles dip solder insert		

Connectors M 23 RJ 45 / Housing

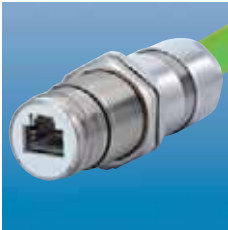
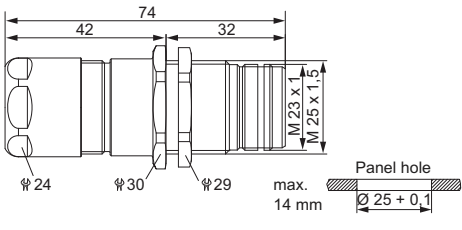
Single Hole Panel Connector with strain relief	Cable-Ø	Part Number
 	<p>Single Hole, Rear Mount , M25 x 1,5 thread 3 – 7 mm (.12 - .28")7.R52.408.000 Incl. 8 poles coupler, fully occupied</p> <p>M25 x 1,5 Locking Nut included</p>	

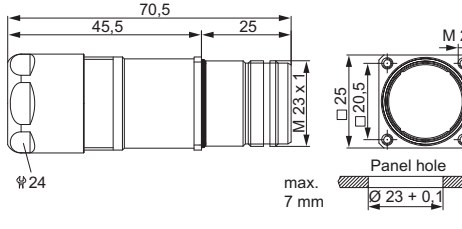
Panel Connector with strain relief	Cable-Ø	Part Number
 	<p>4x M2,5 thread, Flange, Rear Mount 3 – 7 mm (.12 - .28")7.R47.408.000 Incl. 8 poles coupler, fully occupied</p>	

Connectors M 23 RJ 45 / Accessories

Type	Part Number	Accessories
Plastic protective cap for connectors with male thread7.000.900.101 for connectors with female thread7.000.900.102		
Brass protective cap for connectors with female thread7.010.900.183		
Brass protective cap for connectors with male thread7.010.900.102		
Brass protective cap with chain for connectors with female threadLength 70 mm7.010.9S0.783Length 100 mm7.010.9S1.083		
Brass protective cap with chain for connectors with male threadLength 70 mm7.010.9S0.702Length 100 mm7.010.9S1.002		
Adapter flange for straight connectors7.010.900.128		

Connectors M 23 RJ 45 / Accessories

Accessories	Type	Part Number
	Adapter for Conduit Fittings	Snapflex 16..... 7.010.900.204 DN 12 7.010.900.205 Snapflex 20..... 7.010.900.206 DN 14 7.010.900.207 Snapflex 25..... 7.010.900.208 DN 17 7.010.900.209
	Suitable patch cableon request	
	Field attachable RJ45 Connector and Plugson request	

Connectors M 23 RJ45 / Assembly Instructions

Straight Connector, Female Thread

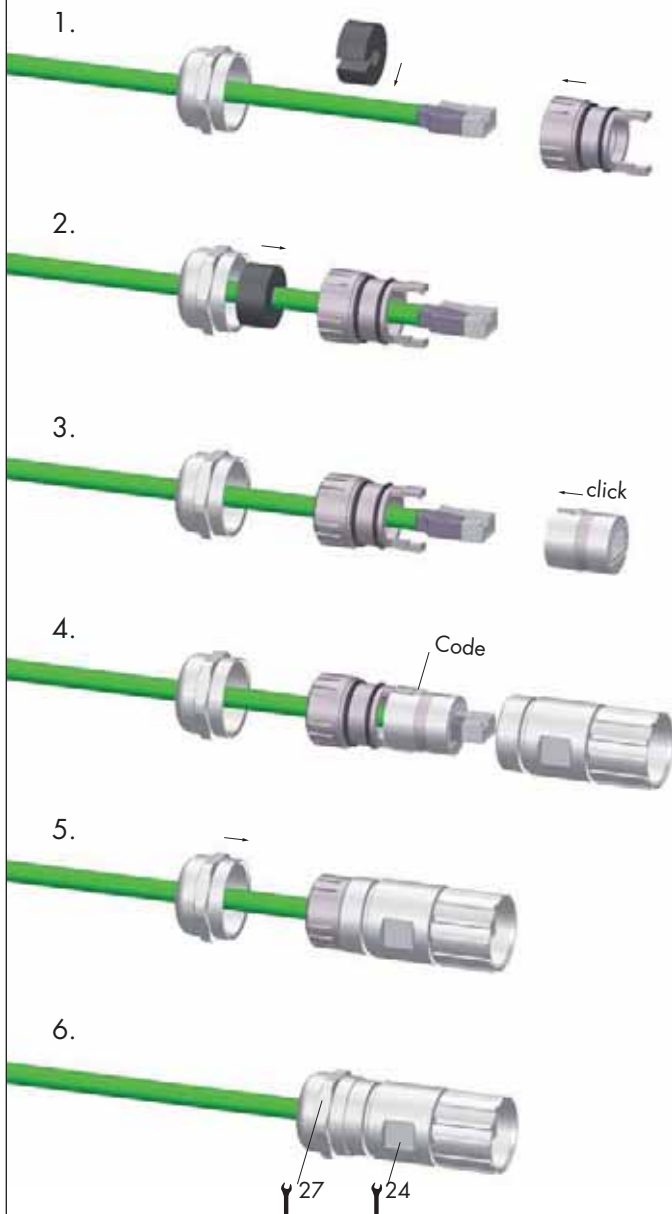

Connectors M 23 RJ 45 / Assembly Instructions

Male Threaded Connector

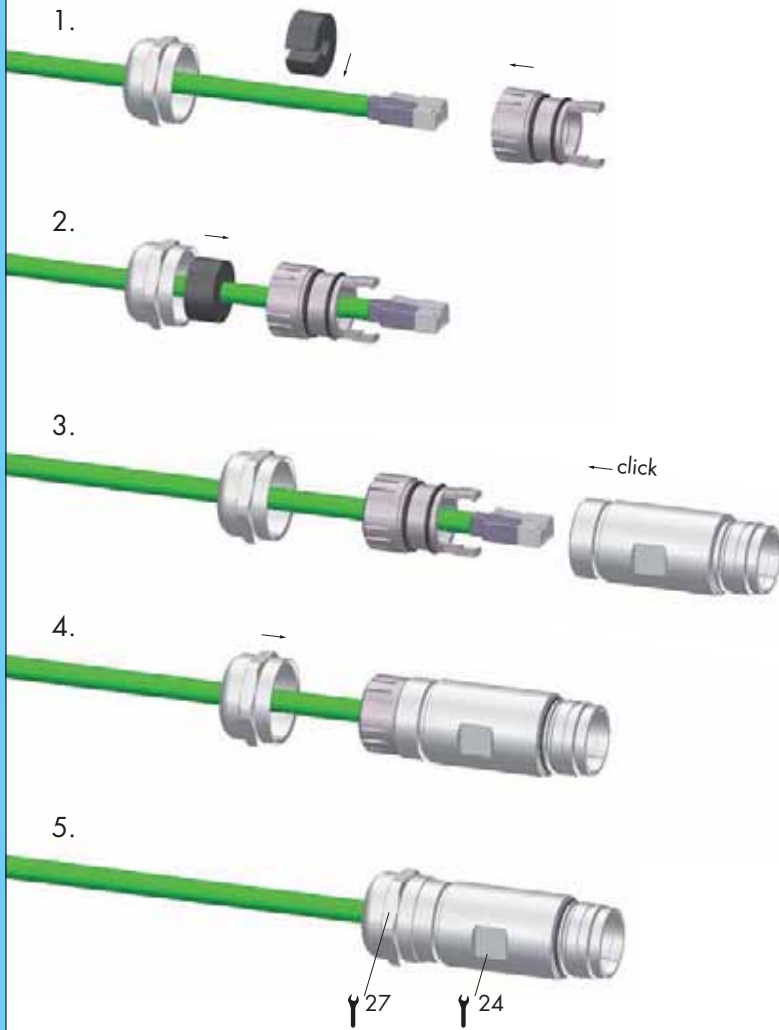

Signal Connectors M 23



Product Overview

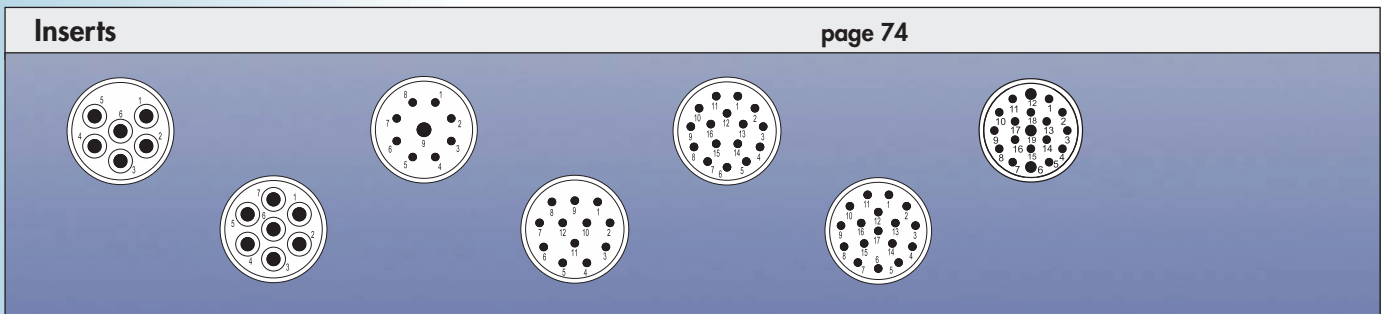

M 23 Signal Connectors

Mechanical Data	Materials and Technical Data
Housing	Copper-Zinc alloy Die Casting
Housing surface	Nickel plated other surface upon request
Inserts (for contacts)	Thermoplastic Polyamid PA 6 (Nylon 6/6), PBT Fire protection class V-0
Contacts	Brass Alloy
Contact surface at point of contact	Nickel and gold plated (0,25µm Au)
Minimum mating cycles	> 1000
Seals / O-Rings	Buna-N standard optional Viton® (Viton is a registered trademark of DuPont)
Temperature range	-40° C – 125° C (-40 °F – 257 °F)
Type of contacts	Crimp, solder, dip-solder (PCB)
Protection	IP 67 / IP 69K per EN 60529 (connected), NEMA 4x
Cable diameter range	3 – 17 mm (.12 – .67")

Electrical Data							
Number of positions	6	7	9 (8+1)	12	16	17	19 (16+3)
Number of contacts	6	7	8 1	12	16	17	16 3
ContactØ [mm]	2	2	1 2	1	1	1	1 1,5
Nominal current ¹⁾ [A]	20	20	8 20	8	8	8	8 10
Nominal voltage ²⁾ [V~] Degree of Protection 2 ³⁾	630	630	500	500	400	400	320
Nominal voltage ²⁾ [V~] Degree of Protection 3 ³⁾	300	300	200	200	160	160	100
Test voltage (Breakdown voltage) ⁴⁾ [V~]	2500	2500	2500	2500	1500	1500	1500
Insulation resistance [mΩ]	> 10 ¹⁰	> 10 ¹⁰	> 10 ¹⁰	> 10 ¹⁰	> 10 ⁶	> 10 ⁶	> 10 ⁶
Max. contact resistance [mΩ]	3	3	3	3	3	3	3

^{1), 2), 3), 4)} See Technical Informations page 14

Signal Connectors M 23 / Housing

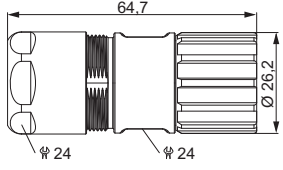

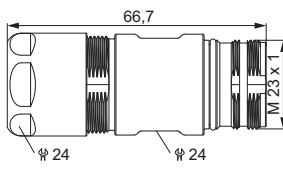
Straight Connector, Female Thread		Cable-Ø	Part Number
		3 – 7 mm (.12 – .28").....	7.106.400.000
		7 – 12 mm (.28 – .47").....	7.106.500.000
		11 – 17 mm (.44 – .67").....	7.106.600.000
Contacts and inserts page 74 • Assembly instructions page 88			

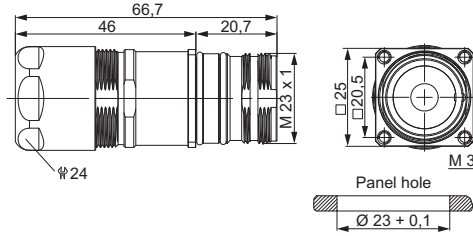

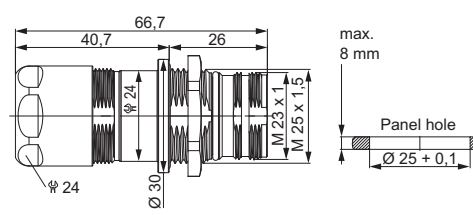
Straight Connector, Male Thread		Cable-Ø	Part Number
		3 – 7 mm (.12 – .28").....	7.206.400.000
		7 – 12 mm (.28 – .47").....	7.206.500.000
		11 – 17 mm (.44 – .67").....	7.206.600.000
Contacts and inserts page 74 • Assembly instructions page 88			

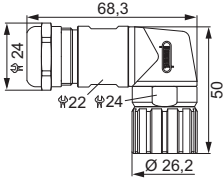

Panel Connector, Male Thread, with Strain Relief		Cable-Ø	Part Number
		4 threads M 3, rear mounting	
		3 – 7 mm (.12 – .28").....	7.476.400.000
		7 – 12 mm (.28 – .47").....	7.476.500.000
		11 – 17 mm (.44 – .67").....	7.476.600.000
		Optional: Flat gasket	
Contacts and inserts page 74 • Assembly instructions page 88			

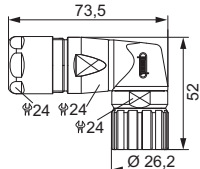

Panel Connector, Male Thread, with Strain Relief		Cable-Ø	Part Number
		Rear mounting, M 25 x 1,5 single hole mounted	
		3 – 7 mm (.12 – .28").....	7.486.400.000
		7 – 12 mm (.28 – .47").....	7.486.500.000
		11 – 17 mm (.44 – .67").....	7.486.600.000
		Including jam nut M 25 x 1,5	
Contacts and inserts page 74 • Assembly instructions page 88			

Signal Connectors M 23 / Housing

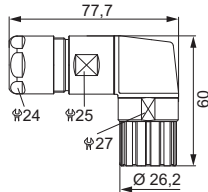
Cable-Ø	Part Number	Right Angle Connector, Female Thread with positioning
3 – 7 mm (.12 – .28")	7.300.300.000	 
5 – 10 mm (.20 – .39")	7.300.400.000	
7 – 12 mm (.28 – .47")	7.300.500.000	
10 – 14 mm (.39 – .55")	7.300.600.000	
Contacts and inserts page 74 • Assembly instructions page 89		

Cable-Ø	Part Number	Right Angle Connector, Female Thread, EMC with positioning
7 – 12 mm (.28 – .47")	7.301.500.000	 
10 – 14 mm (.39 – .55")	7.301.600.000	
Contacts and inserts page 74 • Assembly instructions page 89		

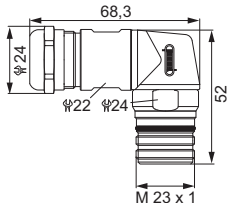
Cable-Ø	Part Number	Right Angle Connector, EMC, rotating
7 – 12 mm (.28 – .47")	7.306.500.000	 
11 – 17 mm (.43 – .67")	7.306.600.000	
Contacts and inserts page 74 • Assembly instructions page 90		

Cable-Ø	Part Number	Right Angle Connector, Male Thread
3 – 7 mm (.12 – .28")	7.350.300.000	 
5 – 10 mm (.20 – .39")	7.350.400.000	
7 – 12 mm (.28 – .47")	7.350.500.000	
10 – 14 mm (.39 – .55")	7.350.600.000	
Contacts and inserts page 74 • Assembly instructions page 89		

Signal Connectors M 23 / Housing

Panel Connector, Male Thread, Front Mounting		Type	Part Number
		4 holes Ø 3,2 mm (.13")	7.400.000.000
		4 threads M 3	7.402.000.000
		4 holes Ø 2,7 mm (.11")	7.404.000.000
		4 threads M 2,5	7.406.000.000
		Optional: Flat gasket	
Contacts and inserts page 74 • Assembly instructions page 91 / 92			

Panel Connector, Male Thread, Front Mounting		Type	Part Number
		With anti-vibration O-Ring	
		4 holes Ø 3,2 mm (.13")	7.410.000.000
		4 threads M 3	7.412.000.000
		4 holes Ø 2,7 mm (.11")	7.414.000.000
		4 threads M 2,5	7.416.000.000
		Optional: Flat gasket	
Contacts and inserts page 74 • Assembly instructions page 91 / 92			

Panel Connector, Female Thread, with knurled Nut		Type	Part Number
		Without coding option	
		4 holes Ø 3,2 mm (.13")	7.440.000.000
		4 holes Ø 2,7 mm (.11")	7.444.000.000
		Optional: Flat gasket	
Contacts and inserts page 74 • Assembly instructions page 90			

Panel Connector, Female Thread, with knurled Nut		Type	Part Number
		With coding option (8 x 45°)	
		4 holes Ø 3,2 mm (.13")	7.448.000.000
		4 holes Ø 2,7 mm (.11")	7.449.000.000
		Optional: Flat gasket	
Contacts and inserts page 74 • Assembly instructions page 90			

Signal Connectors M 23/Housing

Type	Part Number	Panel Connector, Male Thread, Single Hole Mounted	
Front mounting for male inserts Thread M 20 x 1,57.420.000.000 Thread PG 13,57.422.000.000			
Optional: Flat gasket, jam nut M 20 x 1,5 / PG 13,5			
Contacts and inserts page 74 • Assembly instructions page 91			

Type	Part Number	Panel Connector, Male Thread, Single Hole Mounted	
Front mounting for female inserts Thread M 20 x 1,57.421.000.000 Thread PG 13,57.423.000.000			
Optional: Flat gasket, jam nut M 20 x 1,5 / PG 13,5			
Contacts and inserts page 74 • Assembly instructions page 92			

Type	Part Number	Panel Connector, Male Thread, Single Hole Mounted	
For insert with pins / sockets Thread M 25 x 1,57.425.000.000			
Optional: Flat gasket, jam nut M 25 x 1,5			
Contacts and inserts page 74 • Assembly instructions page 91 / 92			

Signal Connectors M 23 / Housing

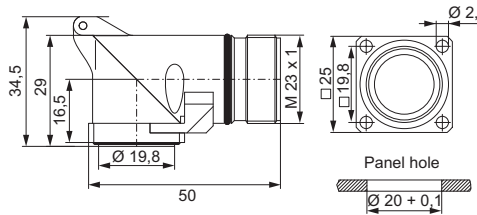
Right Angle Panel Connector, Male Thread		Type	Part Number
		4 holes 2,7 mm (.11").....	7.435.000.000
		Optional: Flat gasket Easy fixation with M2,5 screws Contacts and inserts page 74 • Assembly instructions page 93	

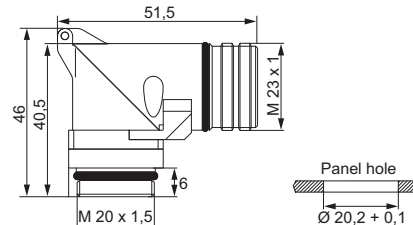
Right Angle Panel Connector, Male Thread, rotating		Type	Part Number
		335° rotating, hole mounted	Thread M20 x 1,5
		Contacts and inserts page 74 • Assembly instructions page 93	7.431.000.000

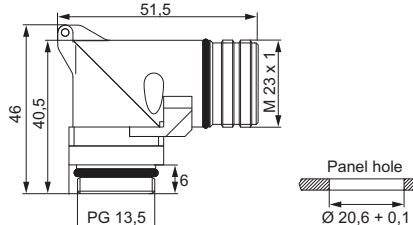
Right Angle Panel Connector, Male Thread, rotating		Type	Part Number
		335° rotating, hole mounted	Thread PG 13,5
		Contacts and inserts page 74 • Assembly instructions page 93	7.432.000.000

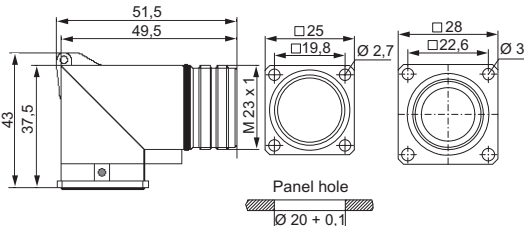
Right Angle Panel Connector, Male Thread, rotating		Type	Part Number
		300° rotating, 1,5 mm locking screw at flange	4 x holes Ø 2,7 mm (.11") ..
		Flange 25 x 25 mm 4 x holes Ø 3,2 mm..... Flange 28 x 28 mm Contacts and inserts page 74 • Assembly instructions page 93	7.433.000.000 7.433.100.000

Signal Connectors M 23 / Housing

Type	Part Number	Panel Connector, Male Thread, Rear Mounting	
4 holes \varnothing 3,2 mm (.13")7.450.000.000		
4 threads M37.452.000.000		
4 holes \varnothing 2,7 mm (.11")7.454.000.000		
4 threads M2,57.456.000.000		
Optional: Flat gasket			
Contacts and inserts page 74 • Assembly instructions page 91 / 92			

Type	Part Number	Panel Connector, Male Thread, Rear Mounting	
With anti-vibration O-Ring			
4 holes \varnothing 3,2 mm (.13")7.460.000.000		
4 threads M37.462.000.000		
4 holes \varnothing 2,7 mm (.11")7.464.000.000		
4 threads M2,57.466.000.000		
Optional: Flat gasket			
Contacts and inserts page 74 • Assembly instructions page 91 / 92			

Type	Part Number	Panel Connector, Male Thread, Single Hole Mounted	
Rear mounting			
Thread M25 x 1,57.458.000.000		
Including jam nut M25 x 1,5			
Contacts and inserts page 74 • Assembly instructions page 91 / 92			

Type	Part Number	Panel Connector, Female Thread, Rear Mounting	
With knurled nut, rear mounting			
4 threads M37.459.000.000		
Contacts and inserts page 74 • Assembly instructions page 90			

Signal Connectors M 23 / Housing

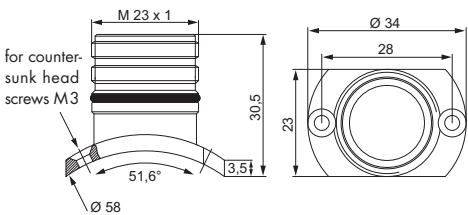
Panel Connector with Radius Flange		Type	Part Number
	 <p>for counter-sunk head screws M3</p>	With anti-vibration O-Ring and flat body gasket Ø 58 mm (2.28")7.490.000.000	
		Contacts and inserts page 74 • Assembly instructions page 91 / 92	

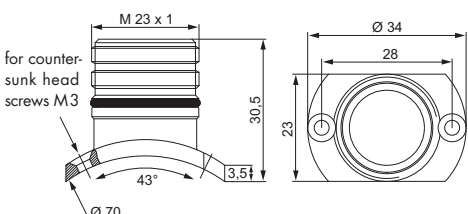
Panel Connector with Radius Flange		Type	Part Number
	 <p>for counter-sunk head screws M3</p>	With anti-vibration O-Ring and flat body gasket Ø 70 mm (2.76")7.491.000.000	
		Contacts and inserts page 74 • Assembly instructions page 91 / 92	

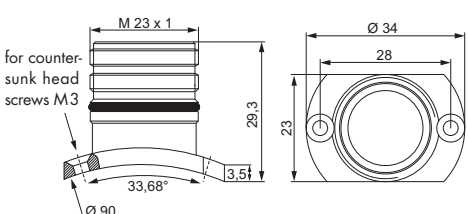
Panel Connector with Radius Flange		Type	Part Number
	 <p>for counter-sunk head screws M3</p>	With anti-vibration O-Ring and flat body gasket Ø 90 mm (3.54")7.492.000.000	
		Contacts and inserts page 74 • Assembly instructions page 91 / 92	

Signal Connectors M 23 / Housing

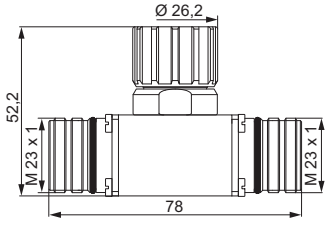
Type	Part Number	Signal Distribution
T 01	7.T01	
<p>Contacts and inserts page 74</p> 		

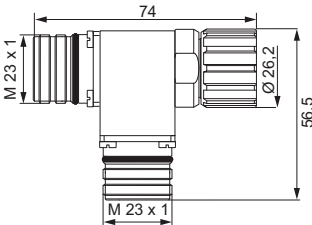
Type	Part Number	Signal Distribution
T 02	7.T02	
<p>Contacts and inserts page 74</p> 		

		Signal Distribution
<p>In case of so called Flying Connections it is often required to distribute, cross or combine signals. Depending on the requirements of the application, the connections can be supplied either as male or female connector, or they can be configured with strain relief fittings. There are many possible combinations, including the internal wiring, independent of their style, as T-, Y-, H-, or other special configurations.</p>		

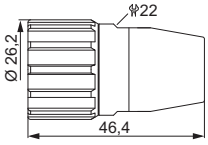
Type	Part Number	Bus End Connector
Closed type	7.105.000.000	
<p>Used to cap an open male connector in bus-systems</p> 		
<p>Contacts and inserts page 74</p>		

Signal Connectors M 23 / Inserts / Pinouts

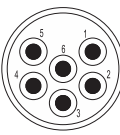
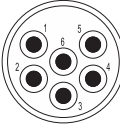
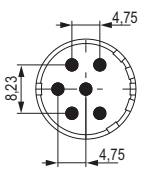
Inserts 6-pole	Type	Part Number	Part Number
 <p>Insert pin mating view (Part E)</p>  <p>Insert socket mating view (Part P)</p> 	Pinout clockwise	Pins	Sockets
	Insert with solder contacts	7.001.906.103	7.001.906.104
	Insert without contacts	7.003.906.101	7.003.906.102
	Insert with dip solder contacts		
	Length 3,5 mm	7.001.906.107	
	Insert with dip solder contacts		
	Length 10 mm	7.001.906.127	7.001.906.108
	Insert with dip solder contacts		
	Length 17 mm	7.001.906.137	7.001.906.118
		The correct dimension of a connector with dip solder contacts depends on the particular type of housing.	
	Contacts page 80 • Coding possibilities N, S, H, X and Y (see page 79)		

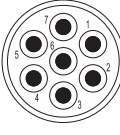
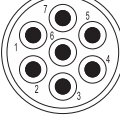
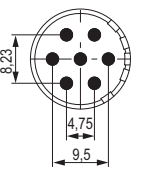
Inserts 7-pole	Type	Part Number	Part Number
 <p>Insert pin mating view (Part E)</p>  <p>Insert socket mating view (Part P)</p> 	Pinout clockwise	Pins	Sockets
	Insert with solder contacts	7.001.907.103	7.001.907.104
	Insert without contacts	7.003.907.101	7.003.907.102
	Insert with dip solder contacts		
	Length 3,5 mm	7.001.907.107	
	Insert with dip solder contacts		
	Length 10 mm	7.001.907.127	7.001.907.108
	Insert with dip solder contacts		
	Length 17 mm	7.001.907.137	7.001.907.118
		The correct dimension of a connector with dip solder contacts depends on the particular type of housing.	
	Contacts page 80 • Coding possibilities N, S, H, X and Y (see page 79)		

Signal Connectors M 23 / Inserts / Pinouts

Type	Part Number	Part Number	Inserts 9-pole (8 + 1)
Pinout clockwise	Pins	Sockets	
Insert with solder contacts	7.001.981.103	7.001.981.104	<p>Insert pin mating view (Part E)</p>
Insert without contacts	7.003.981.101	7.003.981.102	
Insert with dip solder contacts Length 3,5 mm	7.001.981.107		<p>Insert socket mating view (Part P)</p>
Insert with dip solder contacts Length 10 mm	7.001.981.127	7.001.981.108	
Insert with dip solder contacts Length 17 mm	7.001.981.137	7.001.981.118	
<p>The correct dimension of a connector with dip solder contacts depends on the particular type of housing.</p>			
<p>Contacts page 80 • Coding possibilities N, S, H, X and Y (see page 79)</p>			

Type	Part Number	Part Number	Inserts 9-pole (8 + 1)
Pinout counter-clockwise	Pins	Sockets	
Insert with solder contacts	7.002.981.103	7.002.981.104	<p>Insert pin mating view (Part P)</p>
Insert without contacts	7.004.981.101	7.004.981.102	
Insert with dip solder contacts Length 3,5 mm	7.002.981.107		<p>Insert socket mating view (Part E)</p>
Insert with dip solder contacts Length 10 mm	7.002.981.127	7.002.981.108	
Insert with dip solder contacts Length 17 mm	7.002.981.137	7.002.981.118	
<p>The correct dimension of a connector with dip solder contacts depends on the particular type of housing.</p>			
<p>Contacts page 80 • Coding possibilities N, S, H, X and Y (see page 79)</p>			

Signal Connectors M 23 / Inserts / Pinouts

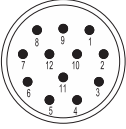
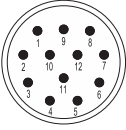
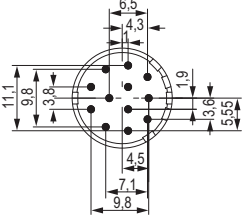
Inserts 12-pole	Type	Part Number	Part Number	
 <p>Insert pin mating view (Part E)</p>  <p>Insert socket mating view (Part P)</p> 	Pinout clockwise	Pins	Sockets	
	Insert with solder contacts	7.001.912.103	7.001.912.104	
	Insert with solder contacts +PE (Pos.9)	7.001.912.113	7.001.912.114	
	Insert without contacts	7.003.912.101	7.003.912.102	
	Insert without contacts +PE (Pos.9)	7.003.912.111	7.003.912.112	
	Insert with dip solder contacts Length 3,5 mm	7.001.912.107		
	Insert with dip solder contacts Length 10 mm	7.001.912.127	7.001.912.108	
	Insert with dip solder contacts Length 17 mm	7.001.912.137	7.001.912.118	
	<p>The correct dimension of a connector with dip solder contacts depends on the particular type of housing.</p>			
	<p>Contacts page 80 • Coding possibilities N, S, H, X and Y (see page 79)</p>			

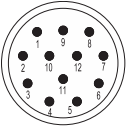
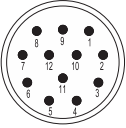
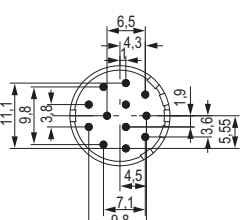
Inserts 12-pole	Type	Part Number	Part Number	
 <p>Insert pin mating view (Part P)</p>  <p>Insert socket mating view (Part E)</p> 	Pinout counter-clockwise	Pins	Sockets	
	Insert with solder contacts	7.002.912.103	7.002.912.104	
	Insert with solder contacts +PE (Pos.9)	7.002.912.113	7.002.912.114	
	Insert without contacts	7.004.912.101	7.004.912.102	
	Insert without contacts +PE (Pos.9)	7.004.912.111	7.004.912.112	
	Insert with dip solder contacts Length 3,5 mm	7.002.912.107		
	Insert with dip solder contacts Length 10 mm	7.002.912.127	7.002.912.108	
	Insert with dip solder contacts Length 17 mm	7.002.912.137	7.002.912.118	
	<p>The correct dimension of a connector with dip solder contacts depends on the particular type of housing.</p>			
	<p>Contacts page 80 • Coding possibilities N, S, H, X and Y (see page 79)</p>			

Signal Connectors M 23 / Inserts / Pinouts

Type	Part Number	Part Number	Inserts 16-pole
Pinout clockwise	Pins	Sockets	
Insert with solder contacts	7.001.916.103	7.001.916.104	<p>Insert pin mating view (Part E)</p>
Insert without contacts	7.003.916.101	7.003.916.102	
Insert with dip solder contacts			<p>Insert socket mating view (Part P)</p>
Length 3,5 mm	7.001.916.107		
Insert with dip solder contacts			
Length 10 mm	7.001.916.127	7.001.916.108	
Insert with dip solder contacts			<p>The correct dimension of a connector with dip solder contacts depends on the particular type of housing.</p>
Length 17 mm	7.001.916.137	7.001.916.118	

Contacts page 80 • Coding possibilities N, S, H, X and Y (see page 79)

Type	Part Number	Part Number	Inserts 17-pole
Pinout clockwise	Pins	Sockets	
Insert with solder contacts	7.001.917.103	7.001.917.104	<p>Insert pin mating view (Part E)</p>
Insert without contacts	7.003.917.101	7.003.917.102	
Insert with dip solder contacts			<p>Insert socket mating view (Part P)</p>
Length 3,5 mm	7.001.917.107		
Insert with dip solder contacts			
Length 10 mm	7.001.917.127	7.001.917.108	
Insert with dip solder contacts			<p>The correct dimension of a connector with dip solder contacts depends on the particular type of housing.</p>
Length 17 mm	7.001.917.137	7.001.917.118	

Contacts page 80 • Coding possibilities N, S, H, X and Y (see page 79)

Signal Connectors M 23 / Inserts / Pinouts

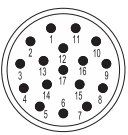
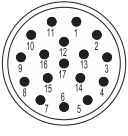
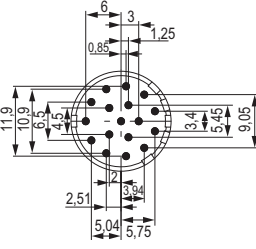
Inserts 17-pole	Type	Part Number	Part Number	
 <p>Insert pin mating view (Part P)</p>  <p>Insert socket mating view (Part E)</p> 	Pinout counter-clockwise	Pins	Sockets	
	Insert with solder contacts	7.002.917.103	7.002.917.104	
	Insert without contacts	7.004.917.101	7.004.917.102	
	Insert with dip solder contacts Length 3,5 mm	7.002.917.107		
	Insert with dip solder contacts Length 10 mm	7.002.917.127	7.002.917.108	
	Insert with dip solder contacts Length 17 mm	7.002.917.137	7.002.917.118	
	The correct dimension of a connector with dip solder contacts depends on the particular type of housing.			
	Contacts page 80 • Coding possibilities N, S, H, X and Y (see page 79)			

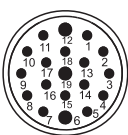
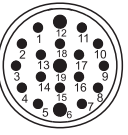
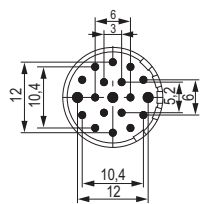
Inserts 19-pole	Type	Part Number	Part Number
 <p>Insert pin mating view (Part E)</p>  <p>Insert socket mating view (Part P)</p> 	Pinout clockwise	Pins	Sockets
	Insert with solder contacts	7.001.919.103	7.001.919.104
	Insert with solder contacts +PE (Pos. 12)	7.001.919.113	7.001.919.114
	Insert with solder contacts + PE (Pos. 12) 1,5 mm elongated	7.001.919.123	
	Insert without contacts	7.003.919.101	7.003.919.102
	Insert without contacts +PE (Pos. 12)	7.003.919.111	7.003.919.112
	Insert with dip solder contacts Length 3,5 mm	7.001.919.107	
	Insert with dip solder contacts Length 10 mm	7.001.919.127	7.001.919.108
	Insert with dip solder contacts Length 17 mm	7.001.919.137	7.001.919.118
	The correct dimension of a connector with dip solder contacts depends on the particular type of housing.		
Contacts page 80 • Coding possibilities N, S, H, X and Y (see page 79)			

Signal Connectors M 23 / Required Contacts





Number of Poles	Required Contacts	Contact Arrangement
6	6 x 2 mm	
7	7 x 2 mm	
9 (8 + 1)	8 x 1 mm 1 x 2 mm	
12	12 x 1 mm	
16	16 x 1 mm	
17	17 x 1 mm	
19	16 x 1 mm 3 x 1,5 mm	

Crimp contacts page 80



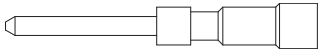
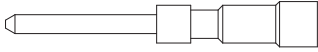
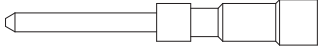

Number of Poles	Coding Possibilities	Coding
6-pole	N, S, H, X, Y and Z	<p>Female Inserts mating view</p>
7-pole	N, S, H, X and Y	
9-pole	N, S, H, X and Y	<p>Male Inserts mating view</p>
12-pole	N, S, H, X, Y and Z	
16-pole	N, S, H, X, Y and Z	
17-pole	N, S, H, X, Y and Z	
19-pole	N, S, H, X and Y	

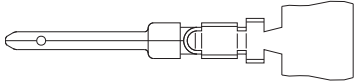
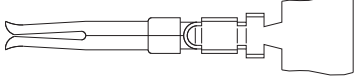
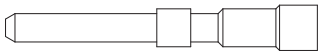
As standard, coding groove N is opened. To use other codings, please remove the coding barrier.

Signal Connectors M23 / Contacts

Contacts	Type	Crimp Range	Part Number
	Crimp pin 1 mm, machined0,08 – 0,56 mm ² (AWG 28 – 20)	..7.010.901.031
	Crimp pin 1 mm, machined0,14 – 1 mm ² (AWG 26 – 17)7.010.901.001
	Crimppin 1 mm, machined0,75 – 1,5 mm ² (AWG 17 – 16)	..7.010.901.021
	Crimp socket 1 mm, machined	...0,08 – 0,56 mm ² (AWG 28 – 20)	..7.010.901.012
	Crimp socket 1 mm, machined	...0,34 – 1 mm ² (AWG 22 – 17)7.010.901.002
	Crimp socket 1 mm, machined	...0,75 – 1,5 mm ² (AWG 17 – 16)	..7.010.901.022
	Crimp pin 1 mm, stamped0,14 – 0,56 mm ² (AWG 26 – 20)	..upon request
	Crimp socket 1 mm, stamped0,14 – 0,56 mm ² (AWG 26 – 20)	..upon request
	Crimp pin 1,5 mm, machined	...0,14 – 1 mm ² (AWG 26 – 17)7.010.901.501

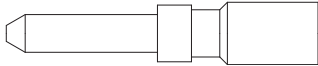
Signal Connectors M23 / Contacts

Type	Crimp Range	Part Number	Contacts
Crimp socket 1,5 mm, machined...	0,14 – 0,56 mm ² (AWG 26 – 20)	..7.010.901.512	
Crimp socket 1,5 mm, machined...	0,56 – 1 mm ² (AWG 20 – 17)7.010.901.502	
Crimp pin 2 mm, machined	0,75 – 2,5 mm ² (AWG 18 – 14)	..7.010.902.001	
Crimp socket 2 mm, machined ...	0,75 – 2,5 mm ² (AWG 18 – 14)	..7.010.902.002	

Crimp Tool Settings see page 86

Signal Connector / Accessories



Accessories	Type	Part Number
	Plastic protective cap for connectors with male thread7.000.900.101 for connectors with female thread.....7.000.900.102	
	Brass protective cap for connectors with female thread.....7.010.900.103	
	Brass protective cap for connectors with male thread7.010.900.102	
	Brass protective cap with chain for connectors with female threadLength 70 mm7.010.9S0.703 Length 100 mm7.010.9S1.003	
	Brass protective cap with chain for connectors with male thread.....Length 70 mm7.010.9S0.702 Length 100 mm7.010.9S1.002	
	Assembly tool7.010.900.101	

Signal Connector / Accessories

Type	Part Number	Accessories
Crimp tool for manual crimping of machined crimp contacts for signal connectors	7.000.900.904	
Operating instructions on page 84 - 86, 94		
Adaptor flange for Straight Connectors	7.010.900.128	
Adapter for Conduit Fittings	Snapflex 16.....7.010.900.204 DN 127.010.900.205 Snapflex 20.....7.010.900.206 DN 147.010.900.207 Snapflex 25.....7.010.900.208 DN 177.010.900.209	

Type	Part Number	for HUMMEL Contact	Locator
Locator for Crimp Tool DMC M22520 with positioner	7.000.9DM.C03	7.010.901.001, 7.010.901.501, 7.010.902.001	
Locator for Crimp Tool DMC M22520 with positioner	7.000.9DM.C04	7.010.901.012, 7.010.901.002, 7.010.901.512, 7.010.901.502, 7.010.902.002	

Crimp Tool for Signal Connectors M 23 / M 16

Crimp Tool	Type	Part Number
	<p>Crimp tool.....7.000.900.904 / 7.000.900.907</p> <p>Application The four indent crimp tool 7.000.900.904 / 7.000.900.907 has been developed for optimal crimping of machined contacts with diameters from 0.08 to 2.5 mm² (28 through 14 AWG).</p> <p>How to Crimp The reference table indicates the correct locator position to be selected and the crimp depth to be adjusted for the contact to be crimped. The contact is then inserted through the access hole of the tool on the opposite side of the locator. The contact is held in place by closing the handles to the first lock-in position thus preventing the contact from falling out of the tool and facilitating insertion of the wire into the contact. The precision ratchet assures consistently accurate crimping every time by forcing the tool to be closed all the way completing the crimping cycle before the tool can be opened again.</p> <p>Exchange of the Locator The locator can be exchanged by removing the socket head cap screw with a socket wrench. It can then be disassembled from the hex head screw by turning it counter-clockwise.</p>	<p>Crimp jaws</p> <p>Adjusting screw with 0.01 mm increments</p> <p>Scale indicating 0.2 mm increments</p> <p>Physical stop</p> 

Crimp Tool for Signal Connectors M23 / M16

Crimp Tool

Adjustment of Crimp Depth

Crimp depth can be adjusted as follows:

Turn the adjusting screw clockwise for reducing the crimp depth and counter-clockwise for increasing the crimp depth.

Adjustment Increments:

- 1 space on the adjusting screw $\hat{=}$ adjustment by 0.01 mm
- 1 full rotation of adjusting screw $\hat{=}$ adjustment by 0.2 mm (indication on the screw as well as on the rough scale)
- 5 rotations of the adjusting screw $\hat{=}$ adjustment by 1 mm (indication on the scale)

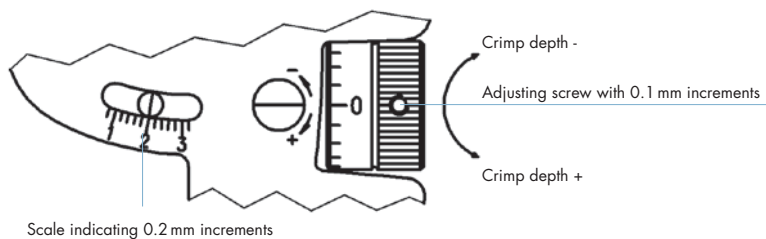

Control of Crimp Depth

Crimp tool adjustment is done at the factory, but with frequent use, periodic calibration is recommended to insure accuracy. This is easily accomplished with a 1.0 mm \varnothing wire gauge as follows.

A crimp depth of 1.0 mm is set by means of the adjusting screw (scale mark at „1“, screw mark at „0“ as shown in the fig. above) and the tool in the closed position. After insertion of the gauge, there must be just enough space for moving the gauge inside the entry hole. If the opening is too small or too large to exactly match the gauge, the deviation (+/-) can be checked by the precision setting of the screw. Please contact the factory in case the deviation exceeds the tolerances specified by the contract manufacturer.

Maintenance and Repair

Keep the tool clean and properly stored when not in service. All pivot points need to be oiled regularly and the spring clips securing the bolts have to always be in place. For repair please send the tool back to the factory.

Crimp Tool for Signal Connectors M23

Crimp Tool Setting for HUMMEL Crimp Contacts (Crimp Tool 7.000.900.904)					
Part Number	Crimp Contact	Cross Section (mm ²)	AWG	Crimp Tool Setting mm	Locator Setting
7.010.901.001	Crimp pin 1 mm	0,14	AWG 26	0,70	1
		0,25	AWG 24	0,76	
		0,34	AWG 22	0,82	
		0,50	AWG 20	0,90	
		0,75	AWG 18	1,00	
		1,00	AWG 17	1,10	
7.010.901.012	Crimp socket 1 mm (0,08 – 0,56 mm ²)	0,08	AWG 28	0,75	2
		0,14	AWG 26	0,78	
		0,25	AWG 24	0,82	
		0,34	AWG 22	0,86	
		0,56	AWG 20	0,90	
7.010.901.002	Crimp socket 1 mm (0,34 – 1 mm ²)	0,34	AWG 22	0,77	2
		0,56	AWG 20	0,82	
		0,75	AWG 18	0,88	
		1,00	AWG 17	0,95	
7.010.901.501	Crimp pin 1,5 mm	0,14	AWG 26	0,65	3
		0,25	AWG 24	0,68	
		0,34	AWG 22	0,72	
		0,56	AWG 20	0,81	
		0,75	AWG 18	0,95	
		1,00	AWG 17	1,07	
7.010.901.512	Crimp socket 1,5 mm (0,14 – 0,56 mm ²)	0,14	AWG 26	0,70	2
		0,25	AWG 24	0,73	
		0,34	AWG 22	0,77	
		0,56	AWG 20	0,85	
7.010.901.502	Crimp socket 1,5 mm (0,34 – 1 mm ²)	0,34	AWG 22	0,88	2
		0,56	AWG 20	0,95	
		0,75	AWG 18	1,05	
		1,0	AWG 17	1,13	
7.010.902.001	Crimp pin 2 mm	0,75	AWG 18	1,20	4
		1,0	AWG 17	1,35	
		1,5	AWG 16	1,45	
		2,5	AWG 14	1,60	
7.010.902.002	Crimp socket 2 mm	0,75	AWG 18	1,25	5
		1,0	AWG 17	1,35	
		1,5	AWG 16	1,45	
		2,5	AWG 14	1,60	

Assembly information see page 94

Crimp Tool for Signal Connectors M 23

Crimp Tool Setting for HUMMEL Crimp Contacts (Crimp Tool 7.000.900.904)					
Part Number	Crimp Contact	Cross Section (mm ²)	AWG	Crimp Tool Setting mm	Locator Setting
7.010.901.031	Crimp pin 1 mm	0,08		0,72	1
		0,14		0,78	
		0,25		0,82	
		0,34		0,86	
		0,56		0,90	
7.010.901.021	Crimp pin 1 mm	0,75		0,80	1
		1,00		0,86	
		1,50		0,95	
7.010.901.022	Crimp socket 1 mm	0,75		0,80	2
		1,00		0,86	
		1,50		0,95	

Signal Connectors M 23 / Assembly Instructions

Straight Connector, Male / Female Thread

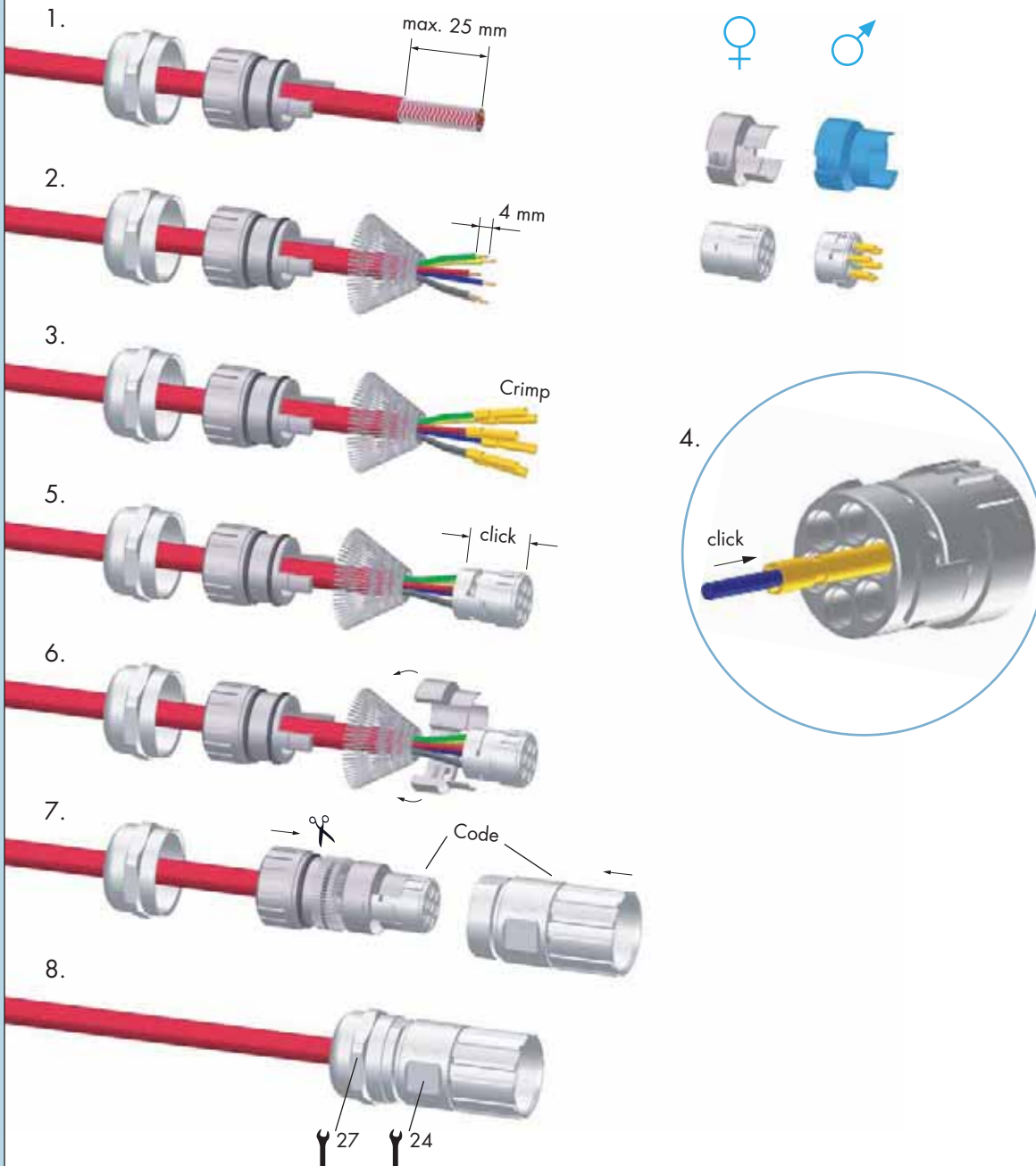

Signal Connectors M23 / Assembly Instructions

Right Angle Connectors, EMC

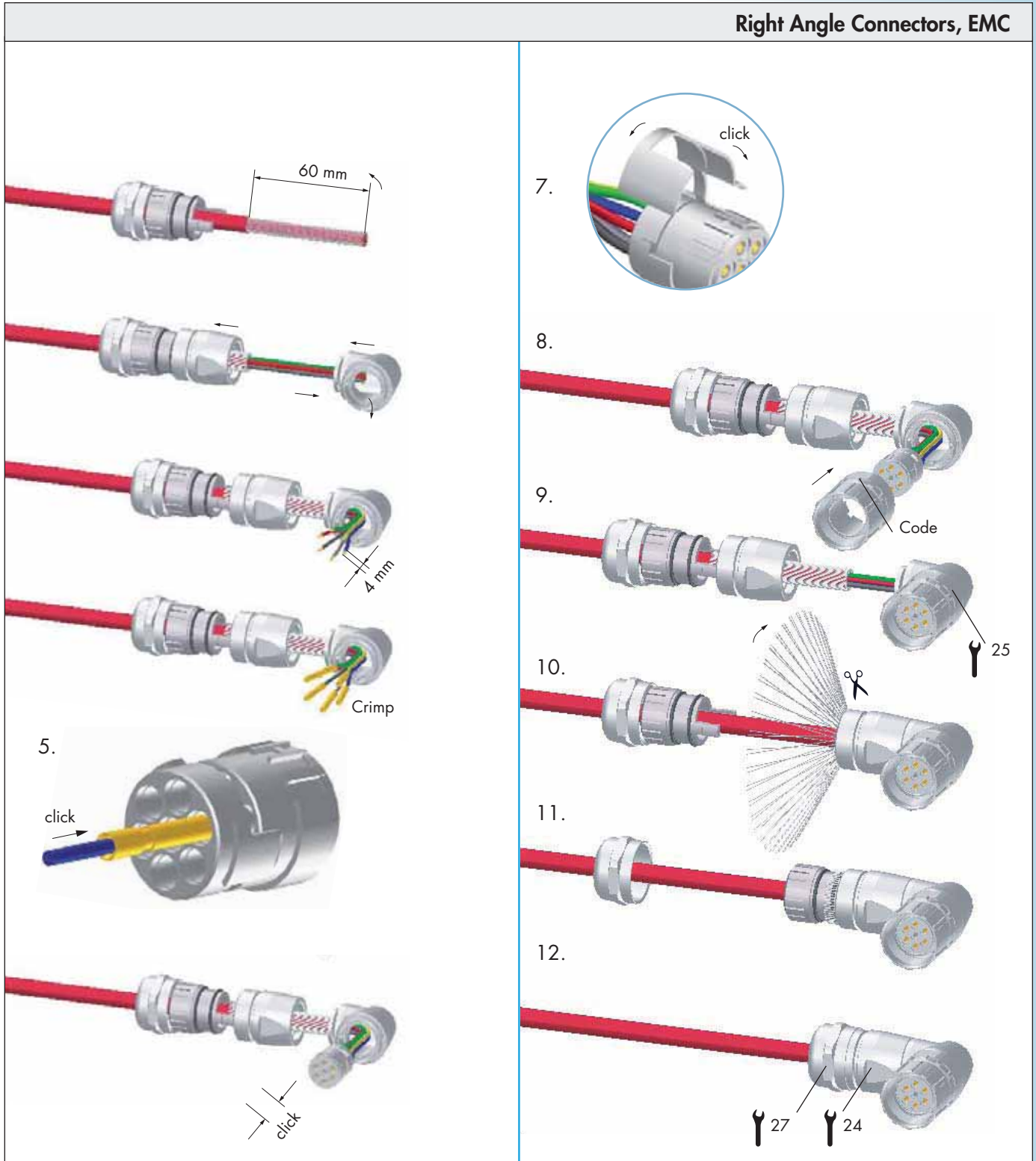

Signal Connectors M 23 / Assembly Instructions

Right Angle Connector, rotating, EMC

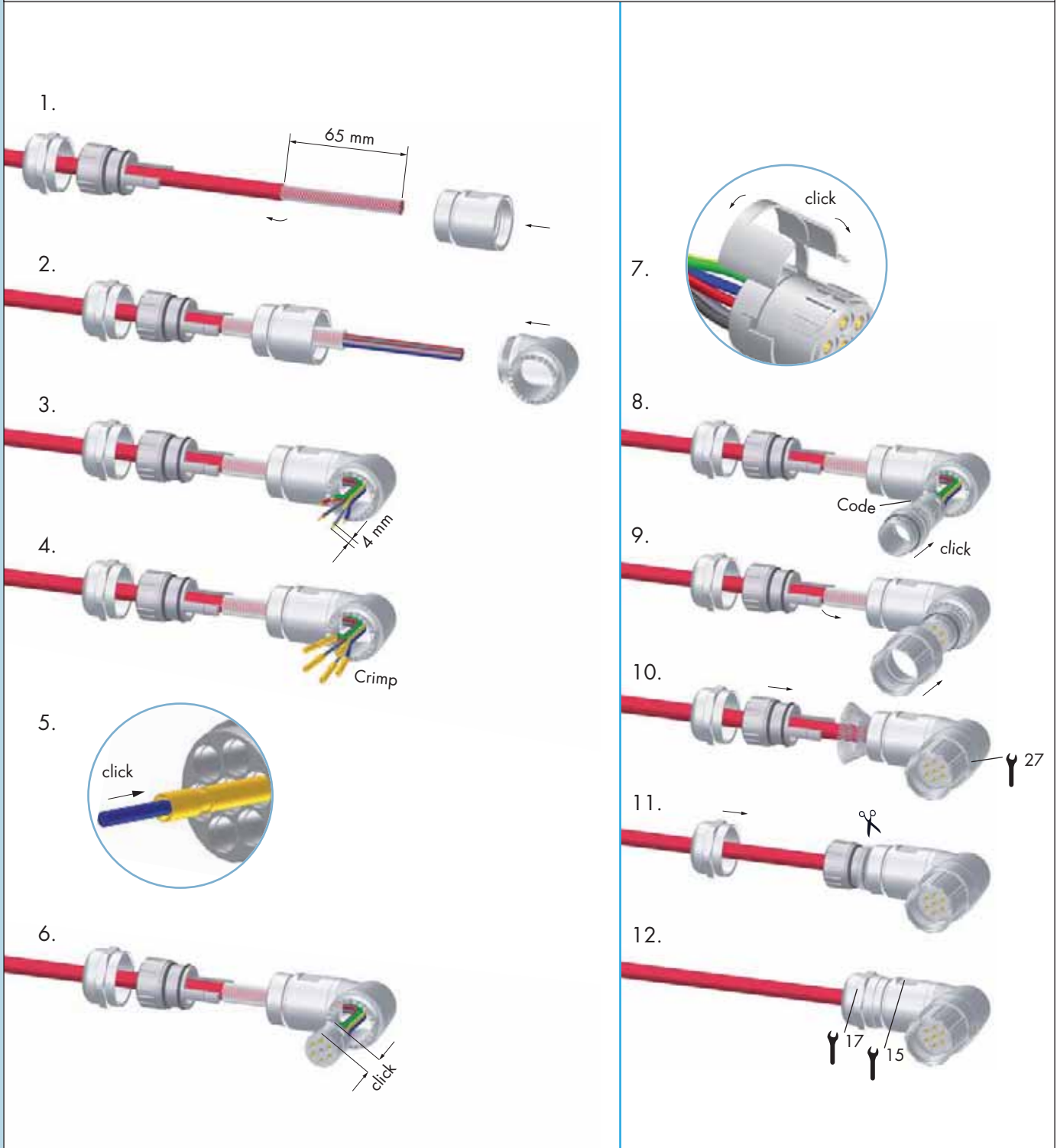

Signal Connectors M23 / Assembly Instructions

Panel Connectors, Male Inserts

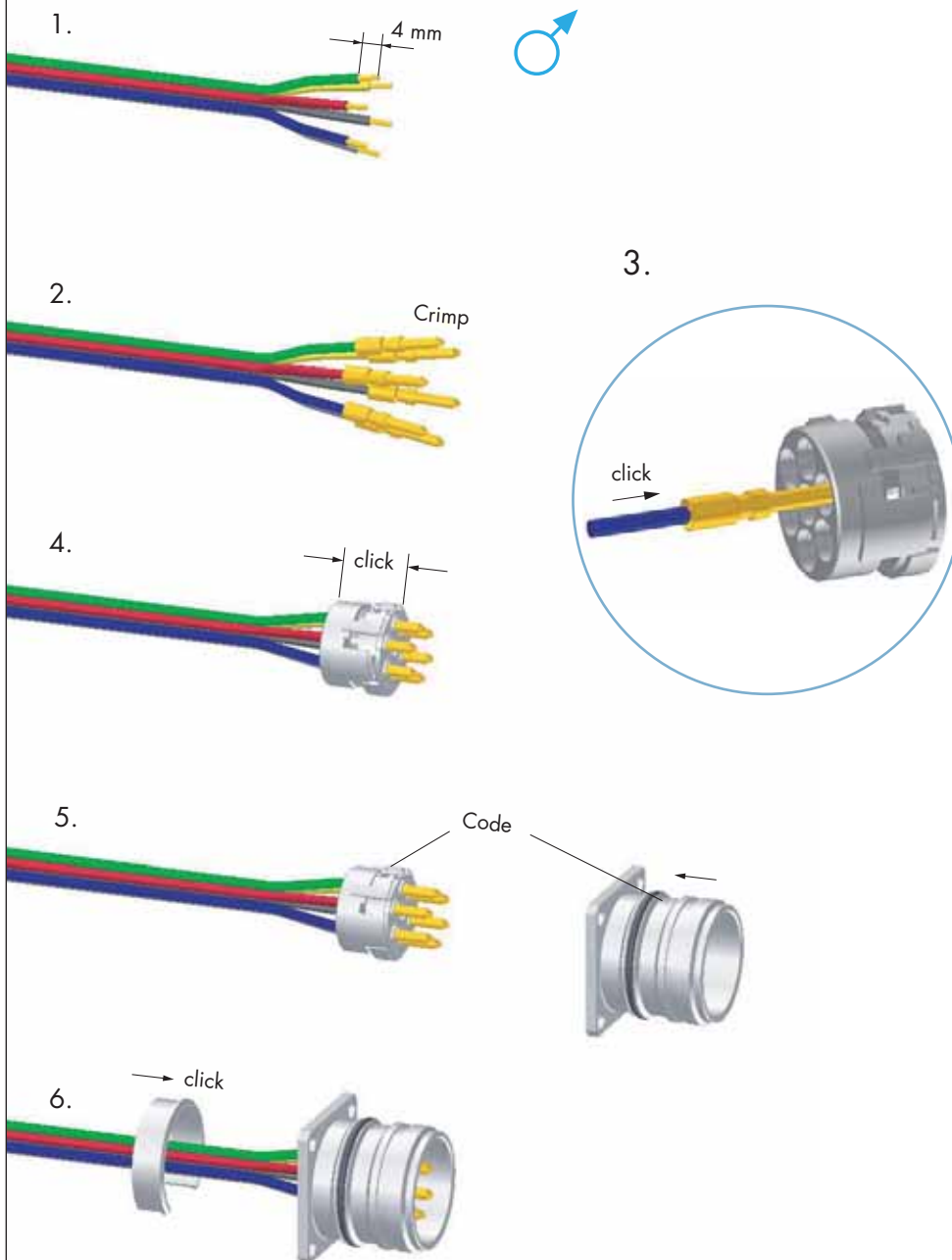

Signal Connectors M 23 / Assembly Instructions

Panel Connectors, Female Inserts

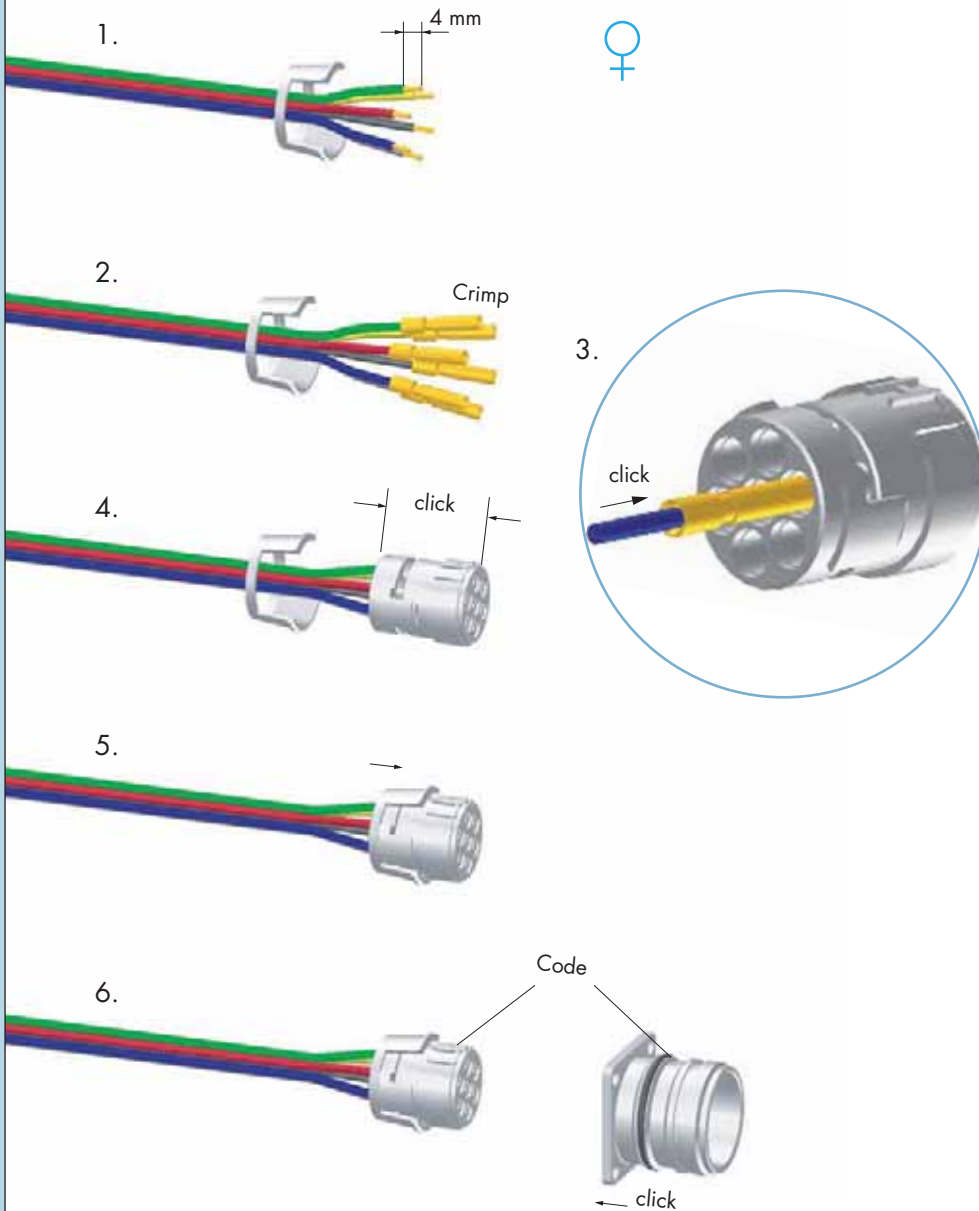

Signal Connectors M23 / Assembly Instructions

Right Angle Panel Connector

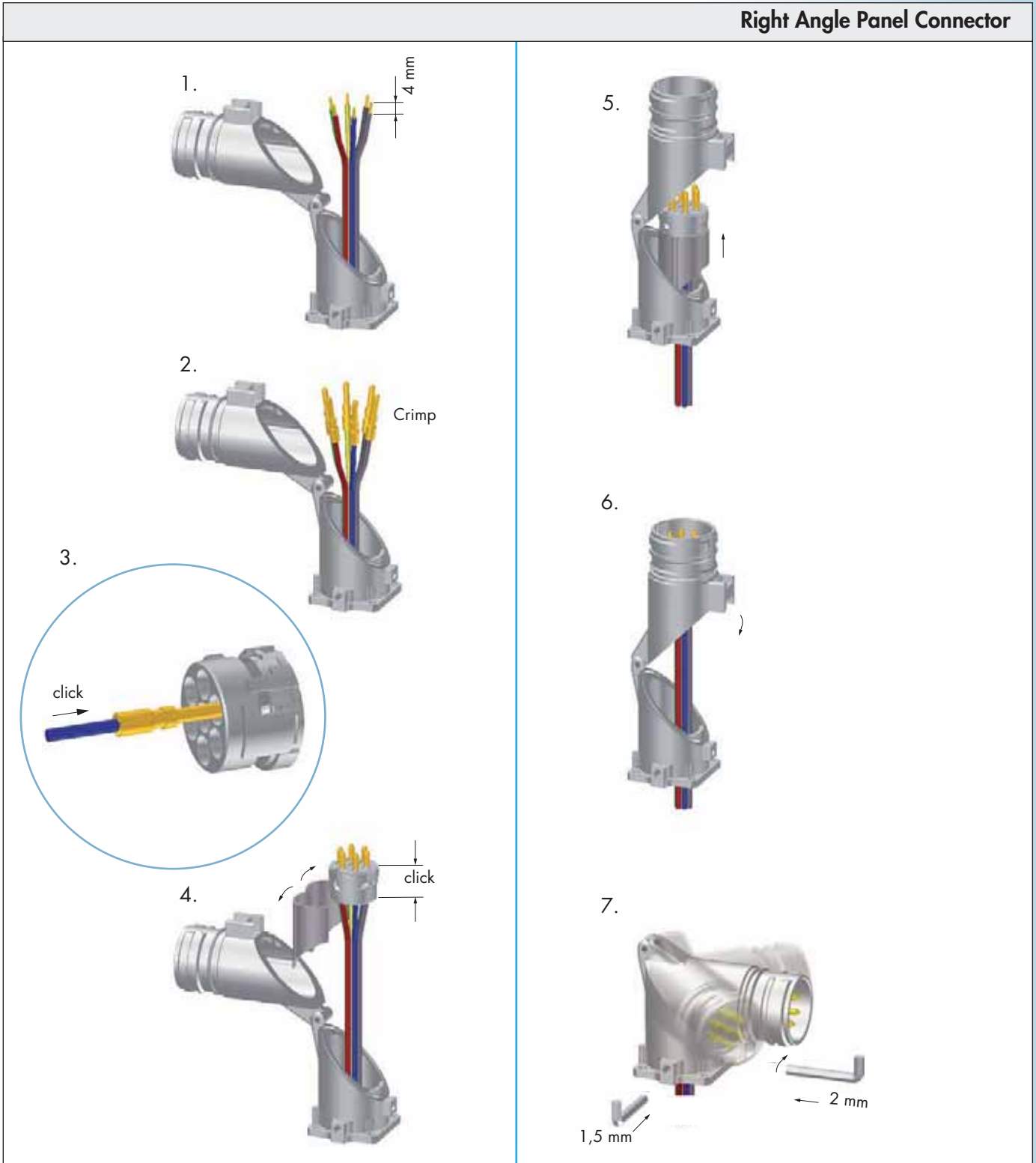

Crimping, Assembly and Disassembly of Contacts

Crimping, Assembly and Disassembly of Contacts

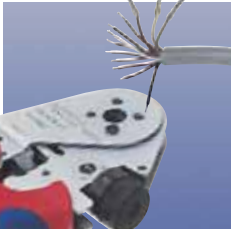

Crimping

- Remove conductor insulation 4 mm (.16") max.
- Select appropriate Crimp tool setting (see page 86)
- Insert Crimp contact into the positioner of the tool
- Insert stripped end of conductor into the crimp opening of the contact
- Squeeze handles of crimp tool together

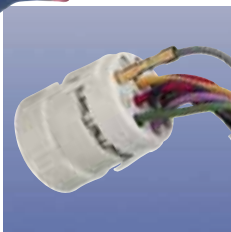

Assembly

- Open crimping jaws and remove contact
- Pry open upper and lower insert approx. 3 mm (1/8") apart as shown
- Insert the contact and conductor assembly into the desired location
- Press upper and lower insert parts together

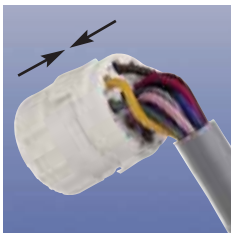

Disassembly

No special tools are needed to remove the crimp contacts from the insert.

- Remove upper part of insert
- With a pair of needle nose pliers, wiggle the contact and push it back through the lower part of insert
- Insert contacts into new location and push until it snaps in position
- Align the nose and groove of the upper and lower part of insert and press together

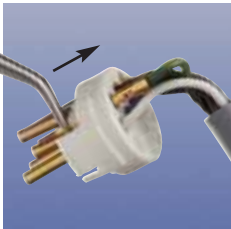

Shielding

- Assemble strain relief insert with insert
- Fold stranding of the shield back over the first O-Ring of the strain relief insert
- Cut back the overextending braid



 The stranding of the shield is not allowed to touch the second O-Ring. Otherwise the assembly may not be proof.

Connectors M 27



Product Overview

Housings	page 98
-----------------	----------------



Inserts	page 99
----------------	----------------



Accessories	page 101
--------------------	-----------------



M 27 Signal Connectors

Mechanical Data	Materials and Technical Data
Housing	Copper-Zinc alloy Die Casting
Housing surface	Nickel plated other surface upon request
Inserts (for contacts)	Thermoplastic Polyamid PA 6 (Nylon 6/6), PBT Fire protection class V-0
Contacts	Brass Alloy
Contact surface at point of contact	Nickel and gold plated (0,25µm Au)
Minimum mating cycles	> 1000
Seals / O-Rings	Buna-N standard optional Viton® (Viton is a registered trademark of DuPont)
Temperature range	-40° C – 125° C (-40 °F – 257 °F)
Type of contacts	Crimp, solder, dip-solder (PCB)
Protection	IP 67 / IP 69 K per EN 60 529 (connected), NEMA 4x
Cable diameter range	7 – 17 mm (.28 – .67")

Electrical Data			
Number of positions		26	28
Number of contacts		26	28
Contact-Ø [mm]		1	1
Nominal current ¹⁾ [A]		8	8
Nominal voltage ²⁾ [V~]		150	150
Test voltage (Breakdown voltage) ³⁾ [V~]		1500	1500
Insulation resistance [MΩ]		> 10 ¹²	> 10 ¹²
Max. contact resistance [mΩ]		3	3
Degree of Protection ⁴⁾		3	3

¹⁾, ²⁾, ³⁾, ⁴⁾ See Technical Informations page 14

Signal Connectors M 27 / Housing

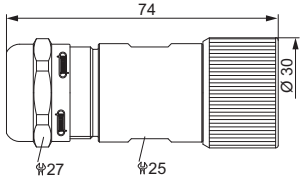
Straight Connector, Female Thread		Cable-Ø	Part Number
		7 – 12 mm (.28 - .47")7.110.500.000	
		11 – 17 mm (.43 - .67")7.110.600.000	
		Contacts and inserts page 99 • Assembly instructions page 103	

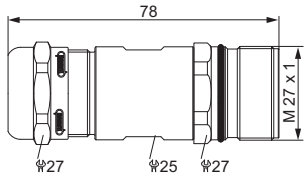
Straight Connector, Male Thread		Cable-Ø	Part Number
		7 – 12 mm (.28 - .47")7.210.500.000	
		11 – 17 mm (.43 - .67")7.210.600.000	
		Contacts and inserts page 99 • Assembly instructions page 103	

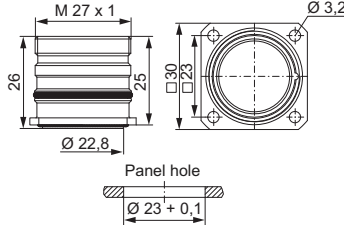
Panel Connector, Male Thread, front mounting		Type	Part Number
		4 x holes 3,2 mm7.410.700.000	
		Contacts and inserts page 99 • Assembly instructions page 104	

Signal Connectors M 27 / Housing

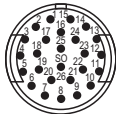
Type	Part Number	Part Number	Inserts 26-pole
Pinout clockwise	Pins	Sockets	
Insert with solder contacts	7.001.926.103	7.001.926.104	 Insert pin mating view
Insert without contacts	7.003.926.101	7.003.926.102	
Insert with dip solder contacts Length 3,5 mm	7.001.926.107		 Insert socket mating view
Insert with dip solder contacts Length 10 mm	7.001.926.127		
<p>The correct dimension of a connector with dip solder contacts depends on the particular type of housing.</p>			
Contacts page 100			

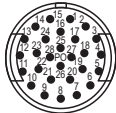
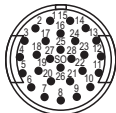
Type	Part Number	Part Number	Inserts 28-pole
Pinout clockwise	Pins	Sockets	
Insert with solder contacts	7.001.928.103	7.001.928.104	 Insert pin mating view
Insert with dip solder contacts Length 3,5 mm	7.001.928.107		
Insert with dip solder contacts Length 10 mm	7.001.928.127		 Insert socket mating view
<p>The correct dimension of a connector with dip solder contacts depends on the particular type of housing.</p>			
Contacts page 100			



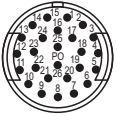
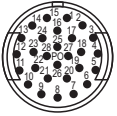

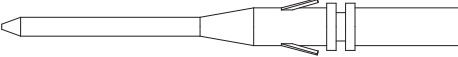
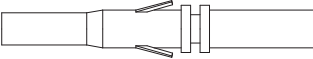
Signal Connectors M 27 / required contacts

Contact Arrangement	Number of Poles	Required Contacts
	26	26 x 1 mm
	28	28 x 1 mm

Contacts	Type	Crimp Range	Part Number
	Crimp pin 1 mm, machined	0,14 – 1 mm ² (AWG 26 – 17)	7.010.971.001
	Crimp socket 1 mm, machined ...	0,14 – 1 mm ² (AWG 26 – 17)	7.010.971.002

Crimp Tool Settings see page 102

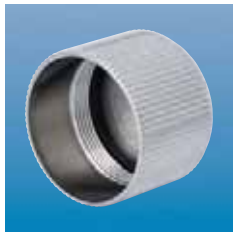
Signal Connectors M27 / Accessories

Type	Part Number	Accessories
Plastic protective cap for connectors with male thread7.000.980.167 for connectors with female thread7.000.980.168		
Brass protective cap for connectors with female thread7.010.900.169 Brass protective cap with chain for connectors with female threadLength 70 mm7.010.9S0.707		
Brass protective cap for connectors with male thread7.010.900.170 Brass protective cap with chain for connectors with male threadLength 70 mm7.010.9S0.708		
Crimp tool for manual crimping of machined crimp contacts. Works with contacts for power or signal M27.7.000.900.901 See page 118/119 for crimp tool instructions and page 102 proper setting		
Assembly tool7.010.900.110		

Crimp Tool for Signal Connectors M 27

Crimp Tool Setting for HUMMEL Crimp Contacts (Crimp Tool 7.000.900.901)

Part Number	Crimp Contact	Cross Section mm ²	AWG	Crimp Tool Setting mm	Locator Setting
7.010.971.001	Crimp pin (signal) 1 mm	0,14	26	0,70	1
		0,25	24	0,80	1
		0,34	22	0,88	1
		0,50	20	0,95	1
		0,75	18	1	1
		1	17	1,03	1
7.010.971.002	Crimp socket (signal) 1 mm	0,14	26	0,70	4
		0,25	24	0,80	4
		0,34	22	0,88	4
		0,50	20	0,95	4
		0,75	18	1	4
		1	17	1,03	4

Signal Connectors M27 / Assembly Instructions

Straight Connector, Female Thread

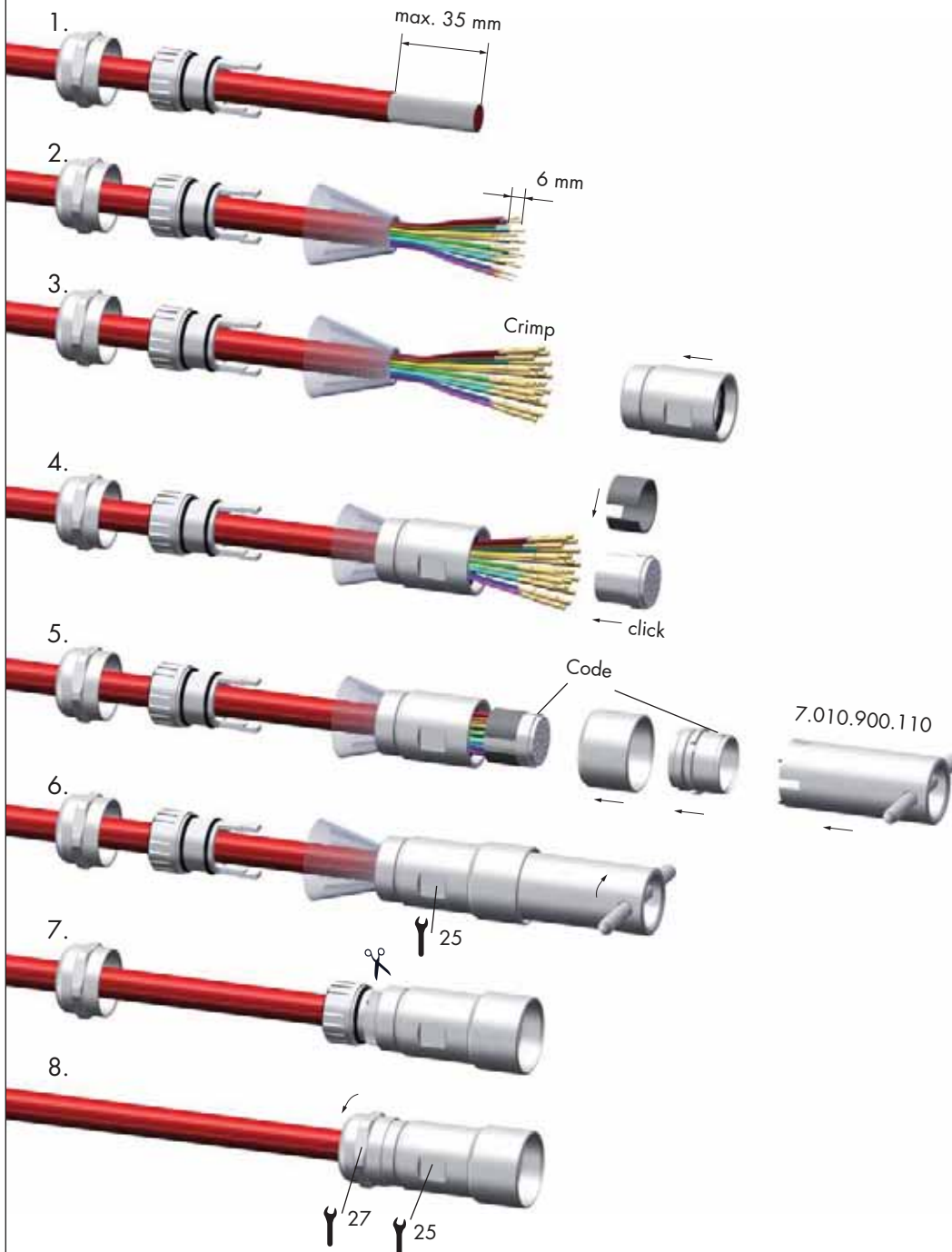

Signal Connectors M 27 / Assembly Instructions

Panel Connector

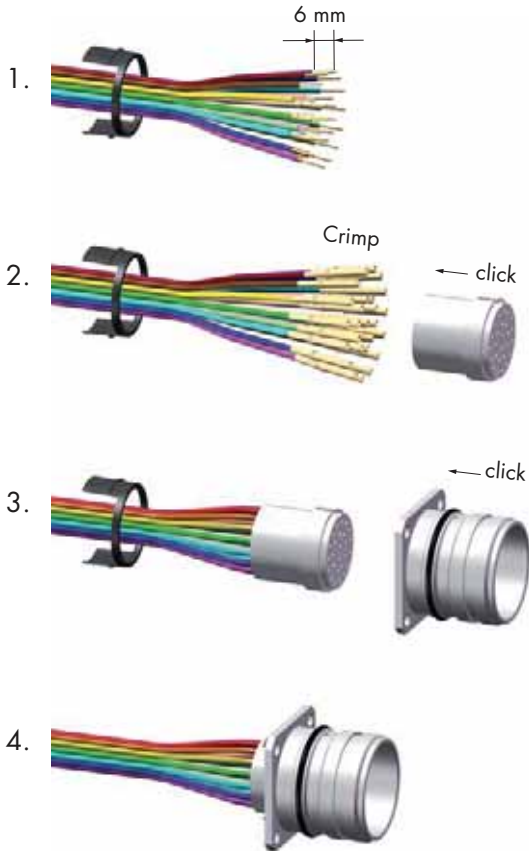

Power Connectors M 23



Product Overview

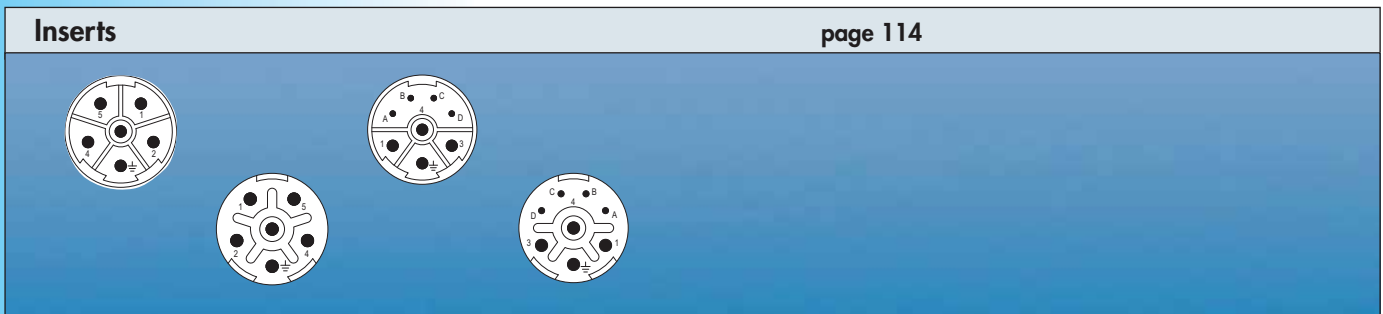

Power Connectors M23

Mechanical Data	Materials and Technical Data
Housing	Copper-Zinc alloy Die Casting
Housing surface	Nickel plated other surface upon request
Inserts (for contacts)	Thermoplastic Polyamid PA 6 (Nylon 6/6), PBT Fire protection class V-0
Contacts	Brass Alloy
Contact surface at point of contact	Nickel and gold plated (0,25 µm Au)
Minimum mating cycles	> 1000
Seals / O-Rings	Buna-N standard optional Viton® (Viton is a registered trademark of DuPont)
Temperature range	-40° C – 125° C (-40 °F – 257 °F)
Type of contacts	Crimp
Protection	IP 67 / IP 69 K per EN 60 529 (connected), NEMA 4x
Cable diameter range	7 – 17 mm (.28 – .67")

Electrical Data			
	5 + PE	4 + 3 + PE	
Number of positions			
Number of contacts	6	4	4
ContactØ [mm]	2	1	2
Nominal current ¹⁾ [A]	28	8	28
Nominal voltage ²⁾ [V~] Degree of Protection 2 ³⁾	800	300	800
Nominal voltage ²⁾ [V~] Degree of Protection 3 ³⁾	600	300	600
Test voltage (Breakdown voltage) ⁴⁾ [V~]	4000	2500	4000
Insulation resistance [mΩ]	> 10 ¹³	> 10 ¹³	
Max. contact resistance [mΩ]	3	3	

^{1), 2), 3), 4)} See Technical Informations page 14

Power Connectors M 23 / Housing

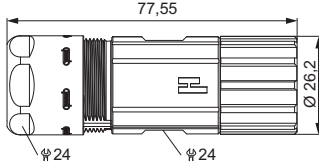
Straight Connector, Female Thread	Cable-Ø	Part number
		7 – 12 mm (.24 – .47").....7.550.500.000 11 – 17 mm (.43 – .67").....7.550.600.000
Contacts and inserts page 114 • Assembly instructions page 122		

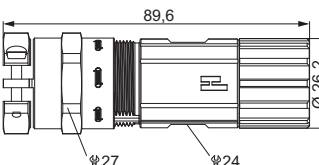
Straight Connector, Female Thread, MZ	Cable-Ø	Part Number
		10 – 12 mm (.39 – .47").....7.559.500.000 11 – 17 mm (.43 – .67").....7.559.600.000
Contacts and inserts page 114 • Assembly instructions page 122		

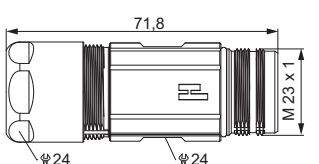
Straight Connector, Male Thread	Cable-Ø	Part Number
		7 – 12 mm (.24 – .47").....7.560.500.000 11 – 17 mm (.43 – .67").....7.560.600.000
Contacts and inserts page 114 • Assembly instructions page 122		

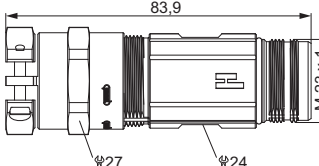
Straight Connector, Male Thread, MZ	Cable-Ø	Part Number
		10 – 12 mm (.39 – .47").....7.569.500.000 11 – 17 mm (.43 – .67").....7.569.600.000
Contacts and inserts page 114 • Assembly instructions page 122		

Power Connectors M 23 / Housing

Cable-Ø	Part Number	Right Angle Connector, Female Thread, rotating
7 – 12 mm (.24 – .47").....	7.576.500.000	
11 – 17 mm (.43 – .67").....	7.576.600.000	
Contacts and inserts page 114 • Assembly instructions page 124		

Cable-Ø	Part Number	Right Angle Connector, Female Thread, MZ, rotating
9 – 12 mm (.35 – .47").....	7.579.500.000	
10 – 14 mm (.39 – .55").....	7.579.600.000	
Contacts and inserts page 114 • Assembly instructions page 124		

Cable-Ø	Part Number	Right Angle Connector, Male Thread, rotating
7 – 12 mm (.24 – .47").....	7.580.500.000	
10 – 14 mm (.39 – .55").....	7.580.600.000	
Contacts and inserts page 114 • Assembly instructions page 124		

Cable-Ø	Part Number	Right Angle Connector, Male Thread, MZ, rotating
9 – 12 mm (.35 – .47").....	7.589.500.000	
10 – 14 mm (.39 – .55").....	7.589.600.000	
Contacts and inserts page 114 • Assembly instructions page 124		

Power Connectors M 23 / Housing

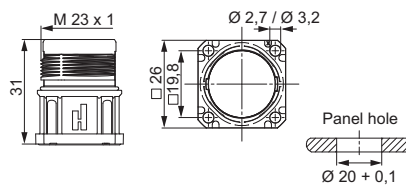
Panel Connectors, Male Thread, Front Mounting		Type	Part Number
		4 holes \varnothing 3,2 mm (.13").....7.601.000.000	
		4 holes \varnothing 2,7 mm (.11").....7.605.000.000	
		Optional: Flat gasket	
		Contacts and inserts page 114 • Assembly instructions page 125	

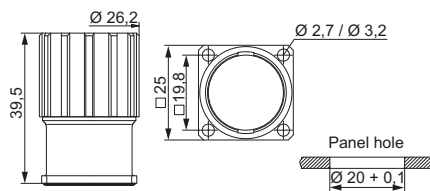
Panel Connector with knurled Nut, Front Mounting		Type	Part Number
		4 holes \varnothing 3,2 mm (.13").....7.641.000.000	
		4 holes \varnothing 2,7 mm (.11").....7.645.000.000	
		Optional: Flat gasket	
		Contacts and inserts page 114 • Assembly instructions page 125	

Power Connectors M 23 / Housing

Type	Part Number	Panel Connector, Male Thread, Single Hole Mounted	
Front mounting Thread M 20 x 1,57.621.000.000			
Options: Flat gasket, jam nut M 20 x 1,5			
Contacts and inserts page 114 • Assembly instructions page 126			



Type	Part Number	Panel Connector, Male Thread, Single Hole Mounted	
Front mounting Thread PG 13,57.623.000.000			
Options: Flat gasket, jam nut PG 13,5			
Contacts and inserts page 114 • Assembly instructions page 126			



Type	Part Number	Panel Connector, Male Thread, Single Hole Mounted	
Front mounting Thread M 25 x 1,57.626.000.000			
Options: Flat gasket, jam nut M 25 x 1,5			
Contacts and inserts page 114 • Assembly instructions page 126			



Type	Part Number	Panel Connector, Male Thread, Single Hole Mounted	
Rear mounting Thread M 25 x 1,57.651.000.000			
Including jam nut M 25 x 1,5			
Contacts and inserts page 114 • Assembly instructions page 126			



Power Connectors M 23 / Housing

Right Angle Panel Connector, Male Thread		Type	Part Number
		4 holes Ø 2,7 mm (.11")7.635.000.000	
		Options: Flat gasket Easy fastening with M2,5 x 10 mm or #4 x .39" long screws	Contacts and inserts page 114 • Assembly instructions page 127

Right Angle Panel Connector, Male Thread, rotating		Type	Part Number
		335° rotating, single hole mounted Thread M 20 x 1,57.636.000.000	
		Contacts and inserts page 114 • Assembly instructions page 127	

Right Angle Panel Connector, Male Thread, rotating		Type	Part Number
		335° rotating, single hole mounted Thread PG 13,57.637.000.000	
		Contacts and inserts page 114 • Assembly instructions page 127	

Right Angle Panel Connector, Male Thread, rotating		Type	Part Number
		300° rotating, locking screw at flange 4 x holes Ø 2,7 mm (.11") ..7.638.000.000 Flange 25 x 25 mm	
		4 x holes Ø 3,2 mm (.13") ..7.638.100.000 Flange 28 x 28 mm	Contacts and inserts page 114 • Assembly instructions page 127

Power Connectors M 23 / Housing

Type	Part Number	Panel Connector, Male Thread, Rear Mounting	
With anti-vibration O-Ring 4 holes $\varnothing 3,2$ mm (.13")7.661.000.000			
Contacts and inserts page 114 • Assembly instructions page 123			

Cable- \varnothing	Part Number	Panel Connector, Male Thread, with Strain Relief	
Single hole mounted, rear mounting, thread M 25 x 1,5 7 – 12 mm (.27 – .47")7.653.500.000 11 – 17 mm (.43 – .67")7.653.600.000			
Including jam nut M 25 x 1,5			
Contacts and inserts page 114 • Assembly instructions page 122			

Cable- \varnothing	Part Number	Panel Connector, Female Thread, with Strain Relief	
4 holes $\varnothing 3,2$ mm (.13"), front or rear mounting 7 – 12 mm (.27 – .47")7.681.500.000 11 – 17 mm (.43 – .67")7.681.600.000			
Contacts and inserts page 114 • Assembly instructions page 122			

Cable- \varnothing	Part Number	Panel Connector, Male Thread, with Strain Relief	
4 holes $\varnothing 3,2$ mm (.13"), front or rear mounting 7 – 12 mm (.27 – .47")7.683.500.000 11 – 17 mm (.43 – .67")7.683.600.000			
Contacts and inserts page 114 • Assembly instructions page 122			

Power Connectors M 23 / Inserts / Pinouts

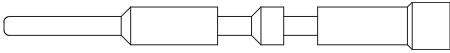
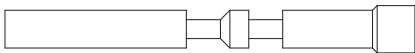
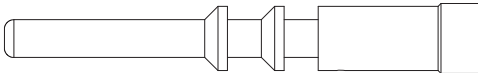
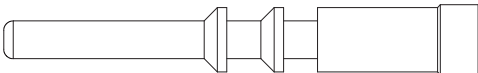
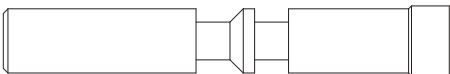
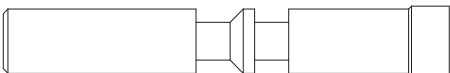

Contact Arrangement, Mating View	Type of Contact	Part Number
	6 x crimp pins 2 mm	7.084.951.101
	6 x crimp sockets 2 mm	7.084.951.102
	4 x crimp pins 1 mm 4 x crimp pins 2 mm	7.084.943.101
	4 x crimp sockets 1 mm 4 x crimp sockets 2 mm	7.084.943.102

Power Connectors M23 / Contacts

Type of Contact	Crimp Range	Part Number	Contacts
Crimp pin 1 mm, machined	0,25 – 1 mm ² (AWG 24 – 17)	7.010.941.001	
Crimp socket 1 mm, machined	0,25 – 1 mm ² (AWG 24 – 17)	7.010.941.002	
Crimp pin 2 mm, machined	0,75 – 2,5 mm ² (AWG 18 – 14)	7.010.942.001	
Crimp pin 2 mm, machined	2,5 – 4 mm ² (AWG 14 – 12)	7.010.942.011	
Crimp socket 2 mm, machined	0,75 – 2,5 mm ² (AWG 18 – 14)	7.010.942.002	
Crimp socket 2 mm, machined	2,5 – 4 mm ² (AWG 14 – 12)	7.010.942.012	

See page 128 for crimp tool instructions and proper setting

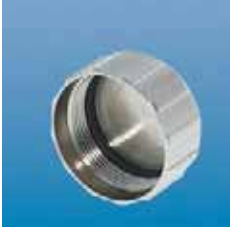
Power Connectors M 23 / Accessories

Accessories	Type	Part Number
	Plastic protective cap for connectors with male thread	7.000.900.101 for connectors with female thread.....
	Brass protective cap for connectors with female thread.....	7.010.900.183
	Brass protective cap for connectors with male thread	7.010.900.102
	Brass protective cap with chain for connectors with female thread	Length 70 mm7.010.9S0.783 Length 100 mm7.010.9S1.083
	Brass protective cap with chain for connectors with male thread	Length 70 mm7.010.9S0.702 Length 100 mm7.010.9S1.002

Power Connectors M 23 / Accessories

Type	Part Number	Accessories
Crimp tool for manual crimping of machined crimp contacts. Works with contacts for power or signal.....	7.000.900.901	
Operating instructions on page 118		
Adaptor flange for Straight Connectors	7.010.900.128	
Adapter for Conduit Fittings	Snapflex 16.....7.010.900.204 DN 127.010.900.205 Snapflex 20.....7.010.900.206 DN 147.010.900.207 Snapflex 25.....7.010.900.208 DN 177.010.900.209	

Type	Part Number	for HUMMEL Contact	Locator
Locator for Crimp Tool DMC M22520 with positioner	7.000.9DM.C06	7.010.941.001, 7.010.942.001, 7.010.942.011	
Locator for Crimp Tool DMC M22520 with positioner	7.000.9DM.C07	7.010.941.002, 7.010.942.002, 7.010.942.012	

Crimp Tool for Power Connectors M 23

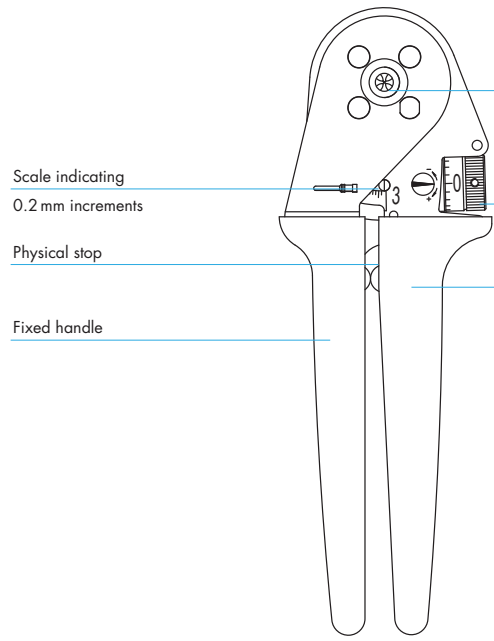
Crimp Tool	Type	Part Number
	<p>Crimp tool7.000.900.901</p> <p>Application The four indent crimp tool 7.000.900.901 has been developed for optimal crimping of machined contacts with diameters from 0.14 to 6.0 mm² (26 through 10 AWG).</p> <p>How to Crimp The reference table indicates the correct locator position to be selected and the crimp depth to be adjusted for the contact to be crimped. The contact is then inserted through the access hole of the tool on the opposite side of the locator. The contact is held in place by closing the handles to the first lock-in position thus preventing the contact from falling out of the tool and facilitating insertion of the wire into the contact. The precision ratchet assures consistently accurate crimping every time by forcing the tool to be closed all the way completing the crimping cycle before the tool can be opened again.</p> <p>Exchange of the Locator The locator can be exchanged by removing the socket head cap screw with a socket wrench. It can then be disassembled from the hex head screw by turning it counter-clockwise.</p>	
		

Crimp Tool for Power Connectors M 23

Crimp Tool

Adjustment of Crimp Depth

Crimp depth can be adjusted as follows:

Turn the adjusting screw clockwise for reducing the crimp depth and counter-clockwise for increasing the crimp depth.

Adjustment Increments:

- 1 space on the adjusting screw $\hat{=}$ adjustment by 0.01 mm
- 1 full rotation of adjusting screw $\hat{=}$ adjustment by 0.2 mm (indication on the screw as well as on the rough scale)
- 5 rotations of the adjusting screw $\hat{=}$ adjustment by 1 mm (indication on the scale)

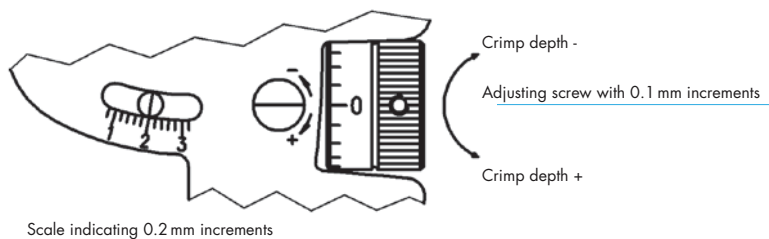

Control of Crimp Depth

Crimp tool adjustment is done at the factory, but with frequent use, periodic calibration is recommended to insure accuracy. This is easily accomplished with a 2.0 mm \varnothing wire gauge as follows.

A crimp depth of 2.0 mm is set by means of the adjusting screw (scale mark at „2“, screw mark at „0“ as shown in the fig. above) and the tool in the closed position. After insertion of the gauge, there must be just enough space for moving the gauge inside the entry hole. If the opening is too small or too large to exactly match the gauge, the deviation (+/-) can be checked by the precision setting of the screw. Please contact the factory in case the deviation exceeds the tolerances specified by the contract manufacturer.

Maintenance and Repair

Keep the tool clean and properly stored when not in service. All pivot points need to be oiled regularly and the spring clips securing the bolts have to always be in place. For repair please send the tool back to the factory.

Crimp Tool for Power Connectors M23

Crimp Tool Setting for HUMMEL Crimp Contacts (Crimp Tool 7.000.900.901)					
Part Number	Crimp Contact	Cross Section mm ²	AWG	Crimp Tool Setting mm	Locator Setting
7.010.901.001	Crimp pin (signal) 1 mm	0,14	26	0,75	11
		0,25	24	0,82	11
		0,35	22	0,9	11
		0,50	20	1	11
		0,75	18	1,08	11
		1,0	17	1,2	11
7.010.901.012	Crimp socket (signal) 1 mm	0,14	26	0,75	12
		0,25	24	0,8	12
		0,35	22	0,87	12
		0,50	20	0,97	12
7.010.901.002	Crimp socket (signal) 1 mm	0,50	20	0,95	12
		0,75	18	1	12
		1,0	17	1,05	12
7.010.901.501	Crimp pin (signal) 1,5 mm	0,14	26	0,75	3
		0,25	24	0,82	3
		0,35	22	0,9	3
		0,50	20	0,96	3
		0,75	18	1,03	3
		1,0	17	1	3
7.010.901.512	Crimp socket (signal) 1,5 mm	0,14	26	0,75	4
		0,25	24	0,8	4
		0,35	22	0,87	4
		0,50	20	0,97	4
7.010.901.502	Crimp socket (signal) 1,5 mm	0,50	20	0,95	4
		0,75	18	1	4
		1,0	17	1,05	4
7.010.902.001	Crimp pin (signal) 2 mm	0,75	18	1,3	5
		1,0	17	1,4	5
		1,5	16	1,55	5
		2,5	14	1,75	5
7.010.902.002	Crimp socket (signal) 2 mm	0,75	18	1,3	6
		1,0	17	1,4	6
		1,5	16	1,55	6
		2,5	14	1,75	6
7.010.941.001	Crimp pin (power) 1 mm	0,14	26	0,75	1
		0,25	24	0,8	1
		0,35	22	0,85	1
		0,50	20	1,03	1
		0,75	18	1,08	1
		1,0	17	1,13	1

Crimp Tool for Power Connectors M 23

Crimp Tool Setting for HUMMEL Crimp Contacts (Crimp Tool 7.000.900.901)

Part Number	Crimp Contact	Cross Section mm ²	AWG	Crimp Tool Setting mm	Locator Setting
7.010.941.002	Crimp socket (power) 1 mm	0,14	26	0,75	2
		0,25	24	0,8	2
		0,35	22	0,85	2
		0,50	20	0,89	2
		0,75	18	0,95	2
		1	17	1,02	2
7.010.942.001	Crimp pin (power) 2 mm	0,75	18	1,3	7
		1	17	1,4	7
		1,5	16	1,55	7
		2,5	14	1,7	7
7.010.942.011	Crimp pin (power) 2 mm	2,5	14	1,47	7
		4	12	1,6	7
7.010.942.002	Crimp socket (power) 2 mm	0,75	18	1,3	8
		1	17	1,4	8
		1,5	16	1,55	8
		2,5	14	1,7	8
7.010.942.012	Crimp socket (power) 2 mm	2,5	14	1,47	8
		4	12	1,6	8

These values are only guidelines and actual conductor cross sections depend on manufacturer tolerances.
Please see assembly instructions on page 128

Power Connectors M 23 / Assembly Instructions

Straight Connector, Female Thread

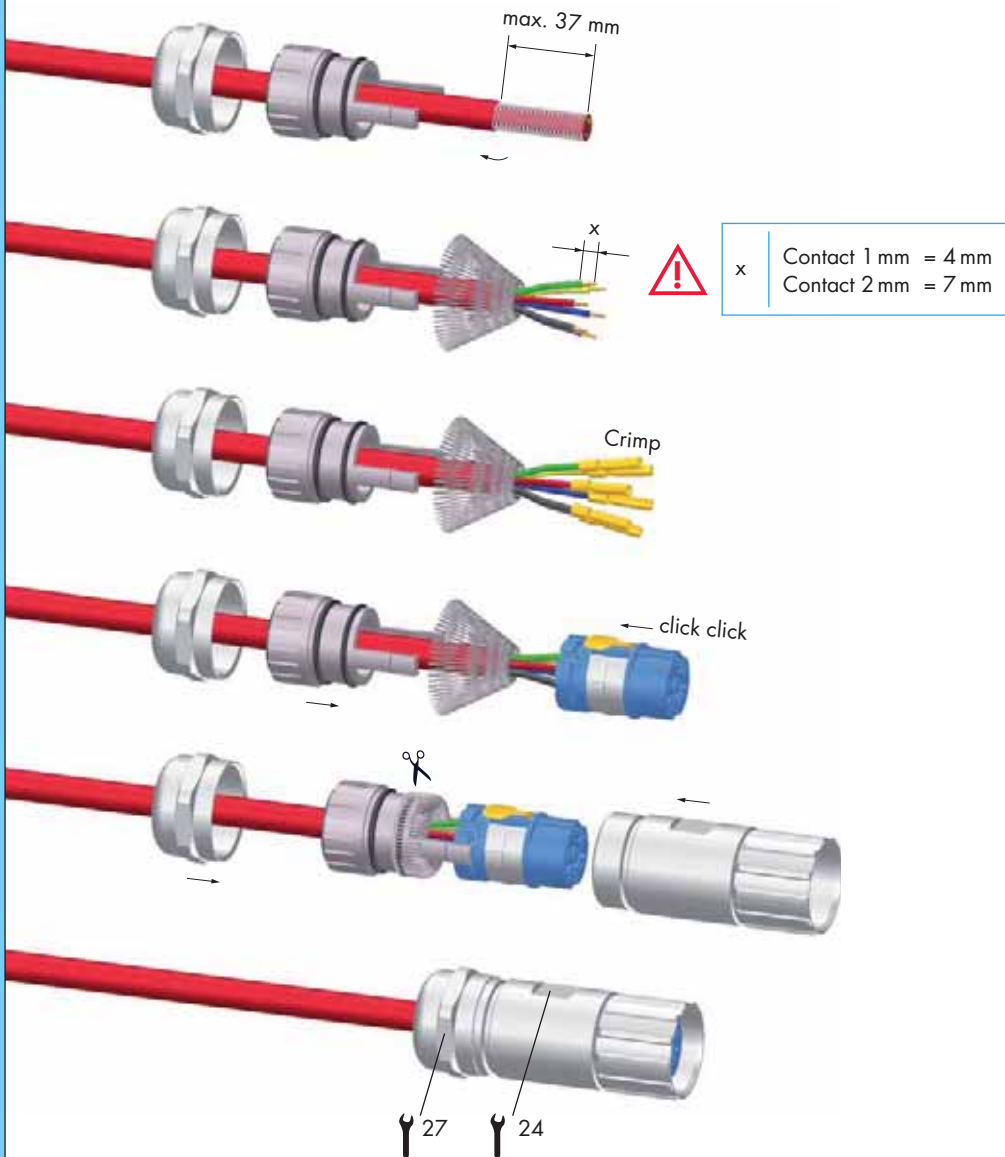

Power Connectors M23 / Assembly Instructions

Panel Connector, Male Thread

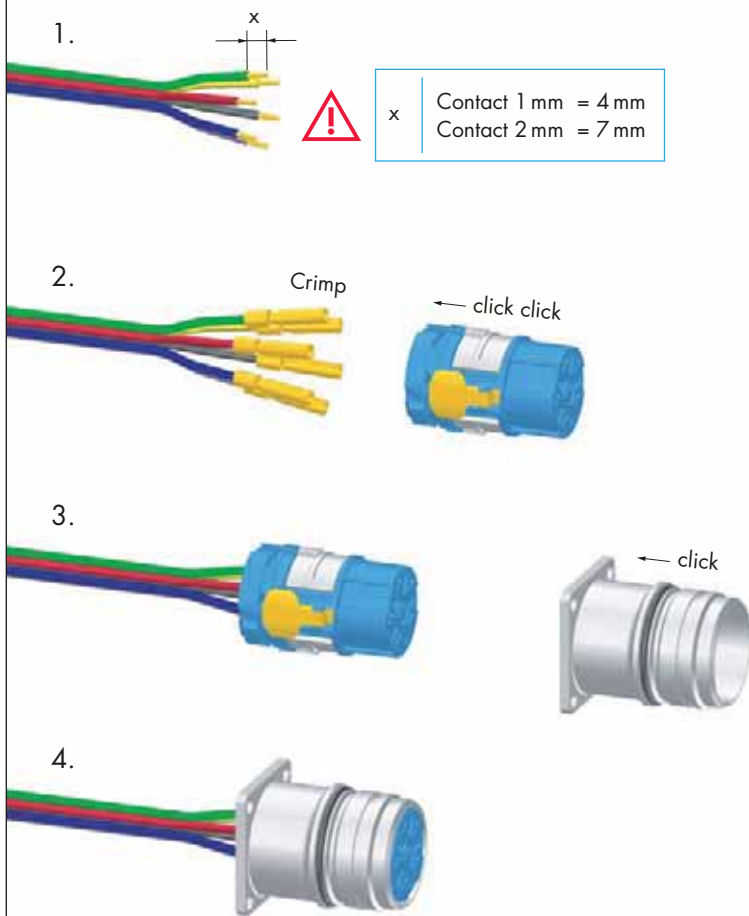

Power Connectors M 23 / Assembly Instructions

Right Angle Connector, rotating

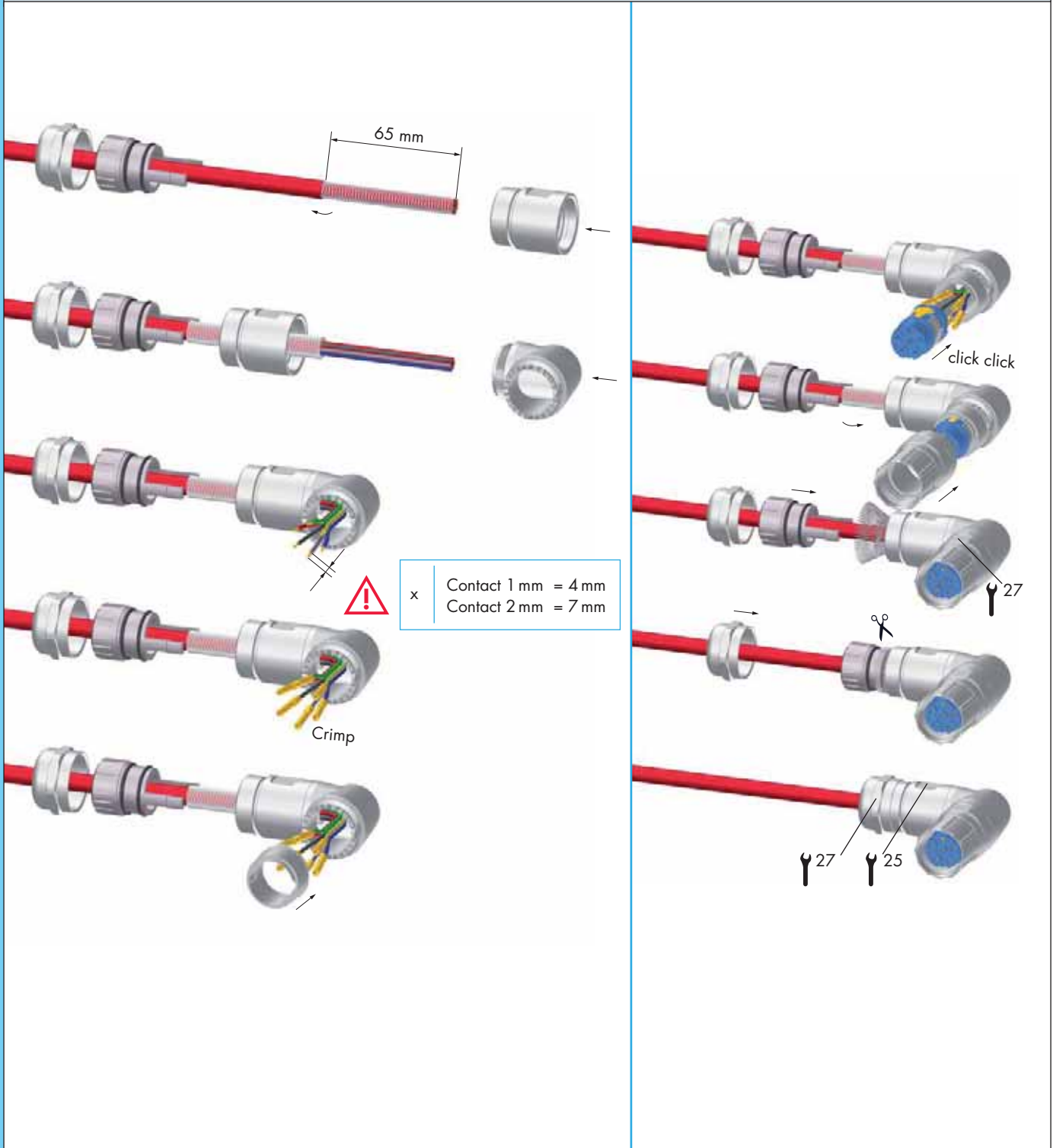

Power Connectors M23 / Assembly Instructions

Panel Connector, Female Thread

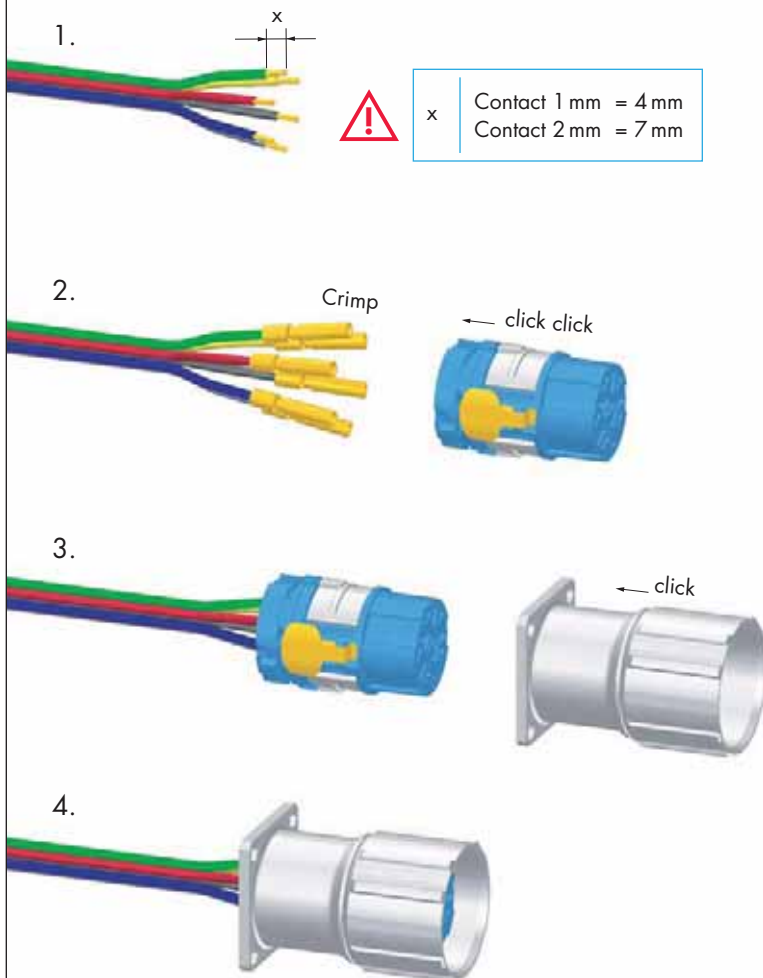

Power Connectors M 23 / Assembly Instructions

Panel Connector, Male Thread, Single Hole Mounted

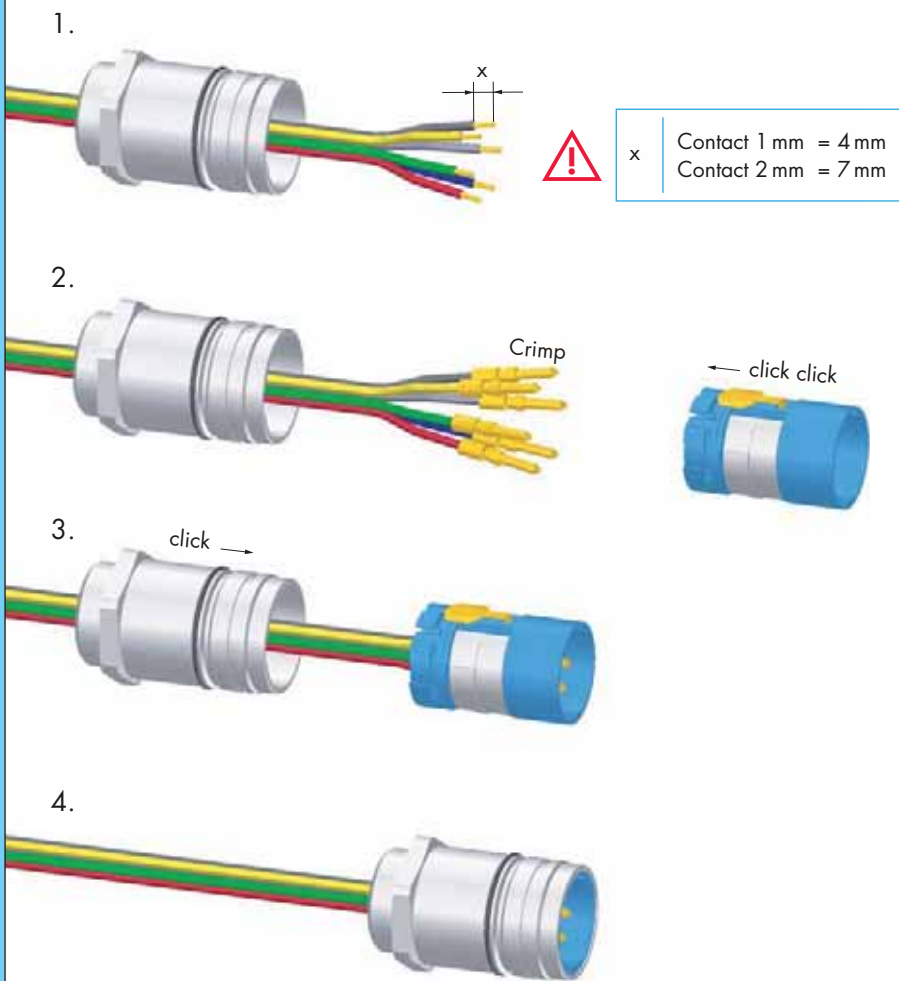

Power Connectors M23 / Assembly Instructions

Right Angle Panel Connector

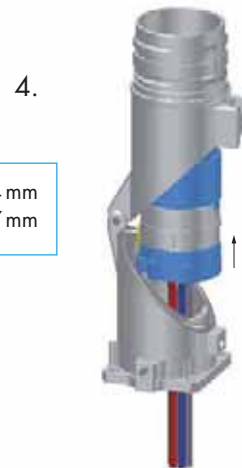
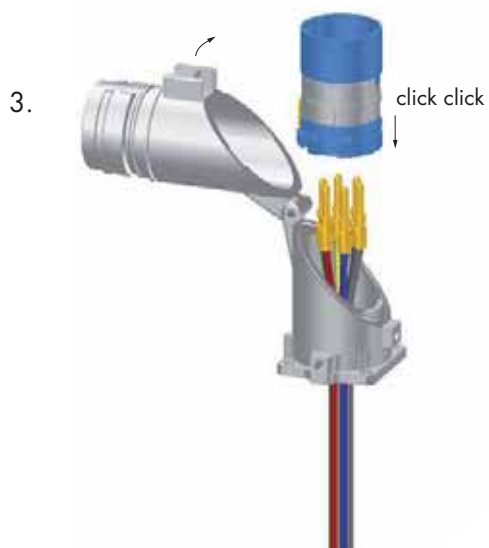
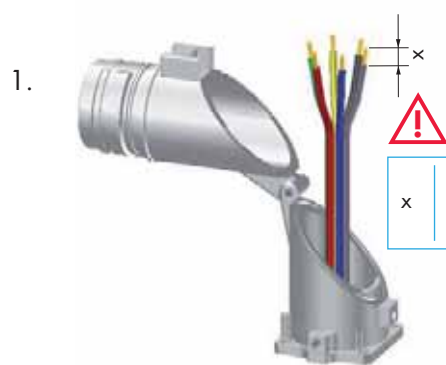

Crimping, Assembly and Disassembly

Crimping, Assembly and Disassembly

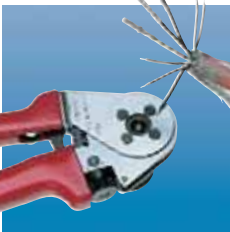

Crimping

- For 1 mm contacts strip wire ends 4 mm (.16") max., for 2 mm contacts strip wire ends 7 mm (.28") max.
- Dial appropriate setting of crimping tool (page 120 / 121)
- Push crimp contact into opening of crimping tool
- Insert stripped wire into the funnel shaped end of the crimp contact
- Squeeze handles of crimping tool together, connecting contact to wire

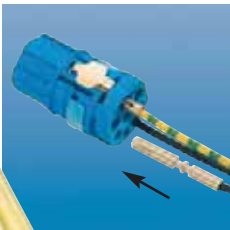

Assembly

- Remove crimped assembly and pull on wire to test connection
- Push into desired position of insert
Note: For 8-pole inserts (4 + 3 + PE) it is recommended to assemble the large contacts first.

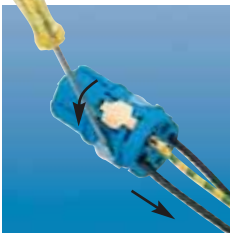

Disassembly of Contacts from Insert

A small screw driver is required.

- Using the screw driver, push the white clip ring out of the insert
- Pull the contacts out of the insert
- Replace the white clip ring
- Reinsert the contacts

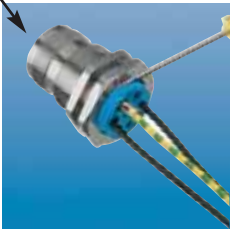

Disassembly of Insert from Housing

A small screw driver is required. Push locking tongue, located above the PE-contact, down. By simultaneously pushing on the front side of the insert, it can be disassembled from the housing.

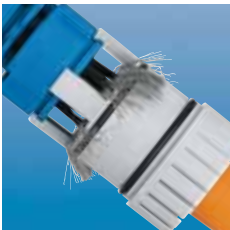

Shielding

- Assemble strain relief insert with insert
- Fold stranding of the shield back over the first O-Ring of the strain relief insert
- Cut back the overextending braid



The stranding of the shield is not allowed to touch the second O-Ring. Otherwise the assembly may not be proof.

Power Connectors Size 1,5 (M 40)



Product Overview

Housings	page 132

Inserts	page 135

Accessories	page 138

Power Connectors Size 1,5 (M40)

Mechanical Data	Materials and Technical Data
Housing	Copper-Zinc alloy Die Casting
Housing surface	Nickel plated, other surface upon request
Inserts (for contacts)	Thermoplastic Polyamid PA 6 (Nylon 6/6), PBT Fire protection class V-0
Contacts	Brass Alloy
Contact surface at point of contact	Nickel and gold plated (0,25 µm Au)
Minimum mating cycles	> 500
Seals / O-Rings	Buna-N standard optional Viton® (Viton is a registered trademark of DuPont)
Temperature range	-40° C – 125° C (-40 °F – 257 °F)
Type of contacts	Crimp
Protection	IP 67 / IP 69 K per EN 60 529 (connected), NEMA 4x
Cable diameter range	13 – 28 mm (.51" – 1.10")

Electrical Data				
Number of positions	3 + 2 + PE		4 + 3 + PE	
Number of contacts	2	4	4	4
ContactØ [mm]	2	3,6	2	3,6
Nominal current ¹⁾ [A]	28	55	28	55
Nominal voltage ²⁾ [V~] Degree of Protection 2 ³⁾	300	800	300	800
Nominal voltage ²⁾ [V~] Degree of Protection 3 ³⁾	300	600	300	600
Test voltage (Breakdown voltage) ⁴⁾ [V~]	2500	4000	2500	4000
Insulation resistance [mΩ]	> 10 ¹³		> 10 ¹³	
Max. contact resistance [mΩ]	3	1	3	1

^{1), 2), 3), 4)} See Technical Informations page 14

 Standard delivery of M40 (size 1.5) Power Connector include Contact Insert

Power Connectors Size 1,5 (M 40)

Straight Connector, Female Thread		Cable-Ø	Part Number
			2 + 3 + PE, insert for sockets 13 – 18 mm (.51 – .71")7.710.623.000 17 – 24 mm (.67 – .97")7.710.723.000 21 – 28 mm (.83 – 1.10") ...7.710.823.000
			Contacts page 136 • Assembly instructions page 145

Straight Connector, Female Thread		Cable-Ø	Part Number
			4 + 3 + PE, insert for sockets 13 – 18 mm (.51 – .71")7.710.643.000 17 – 24 mm (.67 – .97")7.710.743.000 21 – 28 mm (.83 – 1.10") ...7.710.843.000
			Contacts page 136 • Assembly instructions page 145

Straight Connector, Male Thread		Cable-Ø	Part Number
			2 + 3 + PE, insert for pins 13 – 18 mm (.51 – .71")7.720.623.000 17 – 24 mm (.67 – .97")7.720.723.000 21 – 28 mm (.83 – 1.10") ...7.720.823.000
			Contacts page 136 • Assembly instructions page 145

Straight Connector, Male Thread		Cable-Ø	Part Number
			4 + 3 + PE, insert for pins 13 – 18 mm (.51 – .71")7.720.643.000 17 – 24 mm (.67 – .97")7.720.743.000 21 – 28 mm (.83 – 1.10") ...7.720.843.000
			Contacts page 136 • Assembly instructions page 145

Power Connectors Size 1,5 (M40)

Type	Part Number	Panel Connector, Male Thread, Front Mounting			
2+3+PE, insert for pins 4 holes $\varnothing 4,5$ mm (.18")7.740.023.000					
Contacts page 136 • Assembly instructions page 146					

Type	Part Number	Panel Connector, Male Thread, Front Mounting			
4+3+PE, insert for pins 4 holes $\varnothing 4,5$ mm (.18")7.740.043.000					
Contacts page 136 • Assembly instructions page 146					

Type	Part Number	Panel Connector with knurled Nut, Front Mounting			
2+3+PE, insert for sockets 4 holes $\varnothing 4,5$ mm (.18")7.744.023.000					
Contacts page 136 • Assembly instructions page 146					

Type	Part Number	Panel Connector with knurled Nut, Front Mounting			
4+3+PE, insert for sockets 4 holes $\varnothing 4,5$ mm (.18")7.744.043.000					
Contacts page 136 • Assembly instructions page 146					

Power Connectors Size 1,5 (M 40)

Right Angle Panel Connector, Male Thread, rotating		Type	Part Number
		2 + 3 + PE, insert for pins 4 holes Ø 4,5 mm (.18")7.743.023.000	
			Contacts page 136 • Assembly instructions page 147

Right Angle Panel Connector, Male Thread, rotating		Type	Part Number
		4 + 3 + PE, insert for pins 4 holes Ø 4,5 mm (.18")7.743.043.000	
			Contacts page 136 • Assembly instructions page 147



Panel Connector, Male Thread, Single Hole Mounting		Type	Part Number
		Front mounting, 2 + 3 + PE, insert for pins Thread M 40 x 1,57.742.023.000	
			Contacts page 136 • Assembly instructions page 146

Panel Connector, Male Thread, Single Hole Mounting		Type	Part Number
		Front mounting, 4 + 3 + PE, insert for pins Thread M 40 x 1,57.742.043.000	
			Contacts page 136 • Assembly instructions page 146

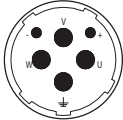
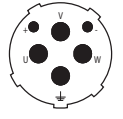
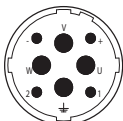
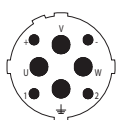
Power Connectors Size 1,5 (M40) / Required Contacts

	Type of Contact	Contact Arrangement, Mating View
Insert for pins 2 + 3 + PE.....	2 x crimp pins 2 mm 4 x crimp pins 3,6 mm	
Insert for sockets 2 + 3 + PE	2 x crimp sockets 2 mm 4 x crimp sockets 3,6 mm	
Insert for pins 4 + 3 + PE.....	4 x crimp pins 2 mm 4 x crimp pins 3,6 mm	
Insert for sockets 4 + 3 + PE	4 x crimp sockets 2 mm 4 x crimp sockets 3,6 mm	

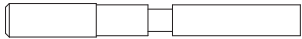
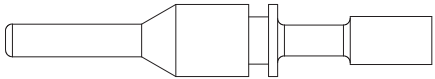
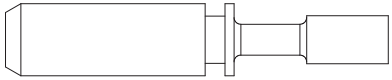
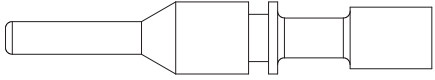
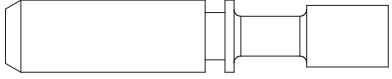
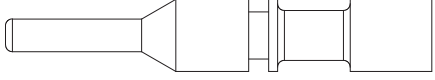
Power Connectors Size 1,5 (M40) / Contacts

Contacts	Type of Contact	Crimp Range	Part Number
	Crimp pin 2 mm, machined0,5 – 4 mm ² (AWG 20 – 12)7.015.952.001
	Crimp socket 2 mm, machined	...0,5 – 4 mm ² (AWG 20 – 12)7.015.952.002
	Crimp pin 3,6 mm, machined1,5 – 4 mm ² (AWG 16 – 12)7.015.953.601
	Crimp socket 3,6 mm, machined	..1,5 – 4 mm ² (AWG 16 – 12)7.015.953.602
	Crimp pin 3,6 mm, machined6 mm ² (AWG 10)7.015.953.611
	Crimp socket 3,6 mm, machined	..6 mm ² (AWG 10)7.015.953.612
	Crimp pin 3,6 mm, machined10 mm ² (AWG 8)7.015.953.621
	Crimp socket 3,6 mm, machined	..10 mm ² (AWG 8)7.015.953.622

For appropriate setting of crimp tool see page 148



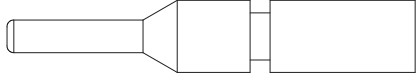
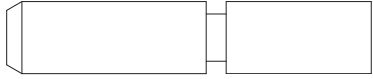



Power Connectors Size 1,5 (M40) / Contacts

Type	Part Number	Contacts
Crimp pin 3,6 mm, machined 16 mm ² (AWG 6)	7.015.953.631	
Crimp socket 3,6 mm, machined.. 16 mm ² (AWG 6)	7.015.953.632	





Crimp Tool Settings see page 144

For appropriate setting of crimp tool see page 148

Power Connectors Size 1,5 (M40) / Accessories

Accessories	Type	Part Number
	Plastic protective cap for connectors with female thread.....	7.000.900.152
	Plastic protective cap for connectors with male thread	7.000.900.151
	Brass protective cap for connectors with female thread.....	7.015.900.103
	Brass protective cap for connectors with male thread	7.015.900.102
	Brass protective cap with rope for connectors with female thread.....	7.015.9S1.003
	Brass protective cap with rope for connectors with male thread	7.015.9S1.002

Power Connectors Size 1,5 (M40) / Accessories

Type	Part Number	Accessories
Adaptor flange for Straight Connectors	7.010.900.129	
Adapter for Conduit Fittings	Snapflex 25.....7.010.900.214 DN 237.010.900.215 Snapflex 32.....7.010.900.216 DN 297.010.900.217	
Crimp tool for manual crimping of machined crimp contacts up to 10 mm ² (AWG 8) for power connectors	7.000.900.902	
See page 140 / 141 for crimp tool instructions and page 144 for proper setting		
Crimp tool for manual crimping of machined crimp contacts 16 mm ² (AWG 6)	7.000.900.903	
See page 142 / 143 for crimp tool instructions and page 144 for proper setting		

Crimp Tool for Power Connectors Size 1,5 (M40)

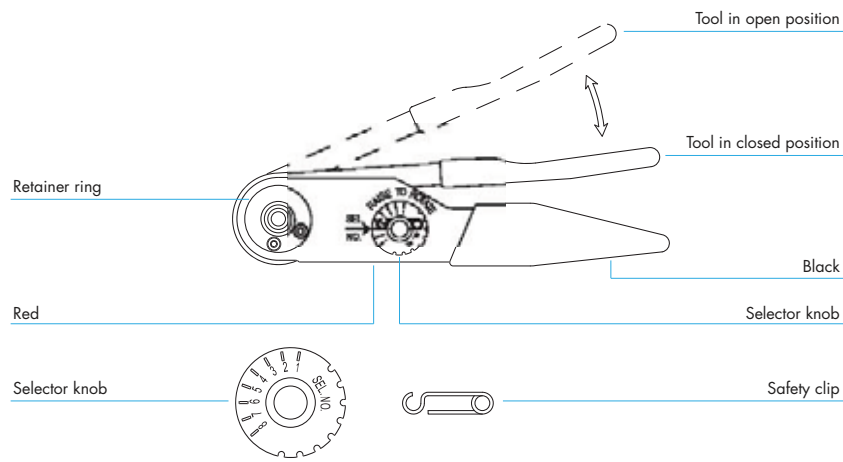
Crimp Tool	Type	Part Number
	<p>Crimp tool7.000.900.902</p> <p>Application The four indent crimp tool 7.000.900.902 has been developed for optimal crimping of machined contacts with diameters from 1 to 10 mm² (18 through 8 AWG).</p> <p>How to Crimp The reference table indicates the correct locator position to be selected and the crimp depth to be adjusted for the contact to be crimped. The contact is then inserted through the access hole of the tool on the opposite side of the locator. The contact is held in place by closing the handles to the first lock-in position thus preventing the contact from falling out of the tool and facilitating insertion of the wire into the contact. The precision ratchet assures consistently accurate crimping every time by forcing the tool to be closed all the way completing the crimping cycle before the tool can be opened again.</p> <p>Exchange of the Locator The locator can be exchanged by removing the socket head cap screw with a socket wrench. Then it can be disassembled from the hex head screw by turning it counter-clockwise.</p>	 <p>Retainer ring</p> <p>Red</p> <p>Selector knob</p> <p>Safety clip</p> <p>Tool in open position</p> <p>Tool in closed position</p> <p>Black</p>

Crimp Tool for Power Connectors Size 1,5 (M40)

Crimp Tool

Setting Up Instructions

1. Tool must be in open position
2. Place selected single position head assembly onto retainer ring with alignment pin in alignment pin hole
3. After single position head is seated against retainer ring, tighten socket head screws with 9/64 inch socket head screw key
4. Refer to dataplate on single position head. From the proper wire size column, determine the selector number that corresponds with the contact being used
5. Remove spring clip lock wire from selector knob. Raise selector knob and rotate until selector number is in line with index mark. Replace spring clip lock wire (optional)

Crimping Instructions

1. Insert contact and prepared wire through the indenter opening into positioner
2. Squeeze handles together until ratchet releases. Handle will return to open position. Remove crimped contact and wire

Removing Single Position Head

Loosen socket head screws until threads are disengaged from retainer ring and remove with a straightlifting motion

Gaging Instructions

The correct function of the crimp tool has to be checked with a gage (item no. 7.010.900.117).

„GO“-Gaging (green)

Operate tool to fully closed position. Maintain firm hand pressure on the tool handles. Insert „GO“ gage end. Gage must pass freely between indenter tips.

„NO-GO“-Gaging (red)

Operate tool to fully closed position. Maintain firm hand pressure on the tool handles. Insert „NO-GO“ gage end. The „NO-GO“ gage may partially enter the indenter opening, but must not pass completely through the opening.

Care of Tool

There is virtually no maintenance required. However, it is a good practice to keep indenter tips free of residual color band deposits and other debris. A small wire brush may be used for this purpose.

We strongly recommend that you:

1. Do not immerse tools in cleaning solution
2. Do not spray oil into tool to lubricate
3. Do not attempt to disassemble tool or make repairs

This is a precision crimp tool and should be handled as such.

Crimp Tool for Power Connectors Size 1,5 (M40)

Crimp Tool	Type	Part Number
	<p>Crimp tool for contacts 16 mm² (AWG 6) 7.000.900.903</p> <p>Application The hand crimp tool 7.000.900.903 has been developed for optimal crimping of a large variety of connectors and terminals by using different interchangeable crimping dies.</p> <p>Operation</p> <ul style="list-style-type: none"> - Select crimp insert and install in tool - Insert and align crimp contact in tool - Compress tool until contact is held in place - Insert conductor into contact - Fully compress tool (tool will reopen automatically) - Remove crimped conductor from tool 	 <p>Die retaining screws</p> <p>Emergency release</p> <p>Stationary jaw with upper die</p> <p>Movable jaw with lower die</p> <p>Set screw</p> <p>Adjustment wheel</p>

Crimp Tool for Power Connectors Size 1,5 (M40)

Crimp Tool

Adjustment of crimp force and height

Crimp force adjustment is done in the factory (120 – 180N when unloaded). Tool frame and jaws are connected that way, an optimal crimping result will be obtained based on the hand force indicated above. In case the result (e.g. crimp height, pull-out force, etc.) does not meet the requirements of the plug manufacturer, the following reasons can be considered:

a) Normal wear of tool

Readjustment possible

b) Worn dies

Dies have to be replaced

The quality personnel is authorized to control and readjust these parameters as described below:

- Unscrew the set screw by means of a screw driver
- Rotating the adjustment wheel anticlockwise, the crimp force increases and the crimp height decreases (+)
- Rotating the adjustment wheel lockwise, the crimp force decreases and the crimp height increases (-)
- When readjusting the hand force shall not exceed 180N
- Before using the tool, the operator has to check the adjustment wheel being firmly secured by the set screw

Maintenance

Keep the tool clean and properly stored when not in service. The joints need to be regularly oiled and the circlips securing the bolts have to be always in place. Never use abrasives or hard material to clean the jaws. Please contact the manufacturer when the tool needs to be repaired or in case of readjustment problems.



Crimp Tool for Power Connectors Size 1,5 (M40)

Crimp Tool Setting for HUMMEL Crimp Contacts (Crimp Tool 7.000.900.902)					
Part Number	Contact	Cross Section mm ²	AWG	Crimp Tool Setting mm	Locator Setting
7.015.952.001	Crimp pin 2 mm	1	17	2	3
		1,5	16	3	3
		2,5	14	4	3
		4	12	4	3
7.015.952.002	Crimp socket 2 mm	1	17	2	1
		1,5	16	3	1
		2,5	14	4	1
		4	12	4	1
7.015.953.601	Crimp pin 3,6 mm	1,5	16	3	2
		2,5	14	4	2
		4	12	5	2
7.015.953.602	Crimp socket 3,6 mm	1,5	16	3	4
		2,5	14	4	4
		4	12	5	4
7.015.953.611	Crimp pin 3,6 mm	6	10	5	2
7.015.953.612	Crimp socket 3,6 mm	6	10	5	4
7.015.953.621	Crimp pin 3,6 mm	10	8	7	2
7.015.953.622	Crimp socket 3,6 mm	10	8	7	4

These values are only guidelines and actual conductor cross sections depend on manufacturer tolerances.
 Assembly information see page 148

Crimp Tool Setting for HUMMEL Crimp Contacts (Crimp Tool 7.000.900.903)				
Part Number	Crimp Contact	Cross Section mm ²	AWG	Crimp Tool Setting
7.015.953.631	Crimp pin 3,6 mm	16	6	die 16
7.015.953.632	Crimp socket 3,6 mm	16	6	die 16

These values are only guidelines and actual conductor cross sections depend on manufacturer tolerances.
 Assembly information see page 148

Power Connectors Size 1,5 (M40) / Assembly Instructions

Straight Connector, Female Thread / Male Threaded Connector

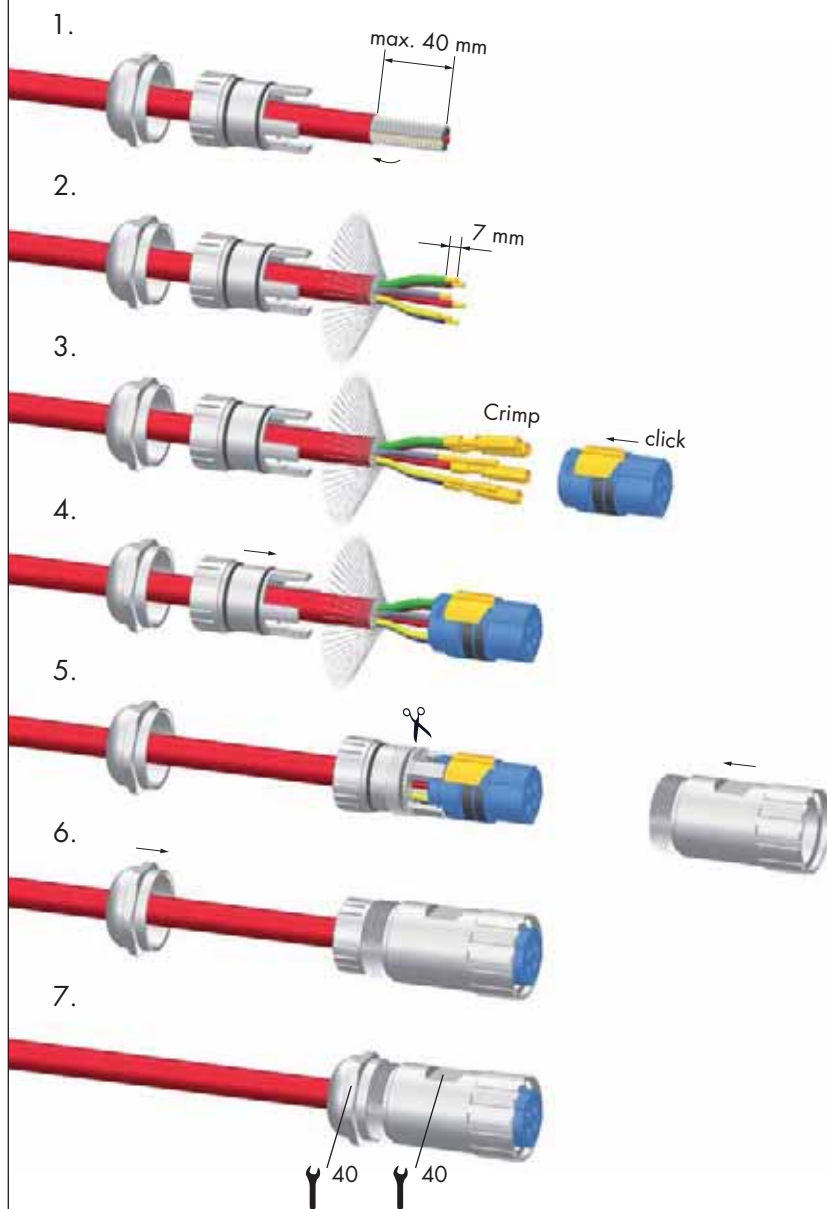

Power Connectors Size 1,5 (M40) / Assembly Instructions

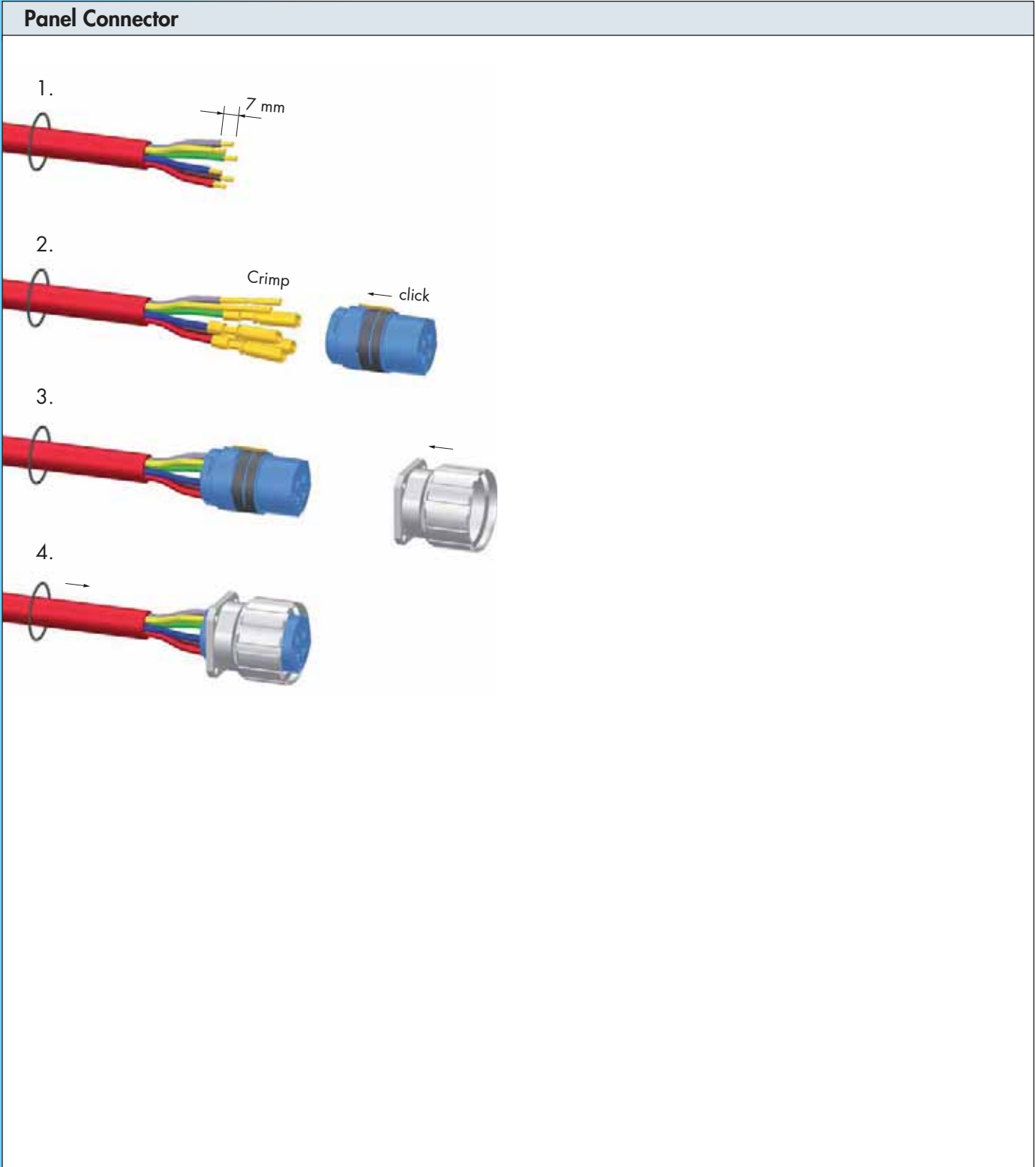

Power Connectors Size 1,5 (M40) / Assembly Instructions

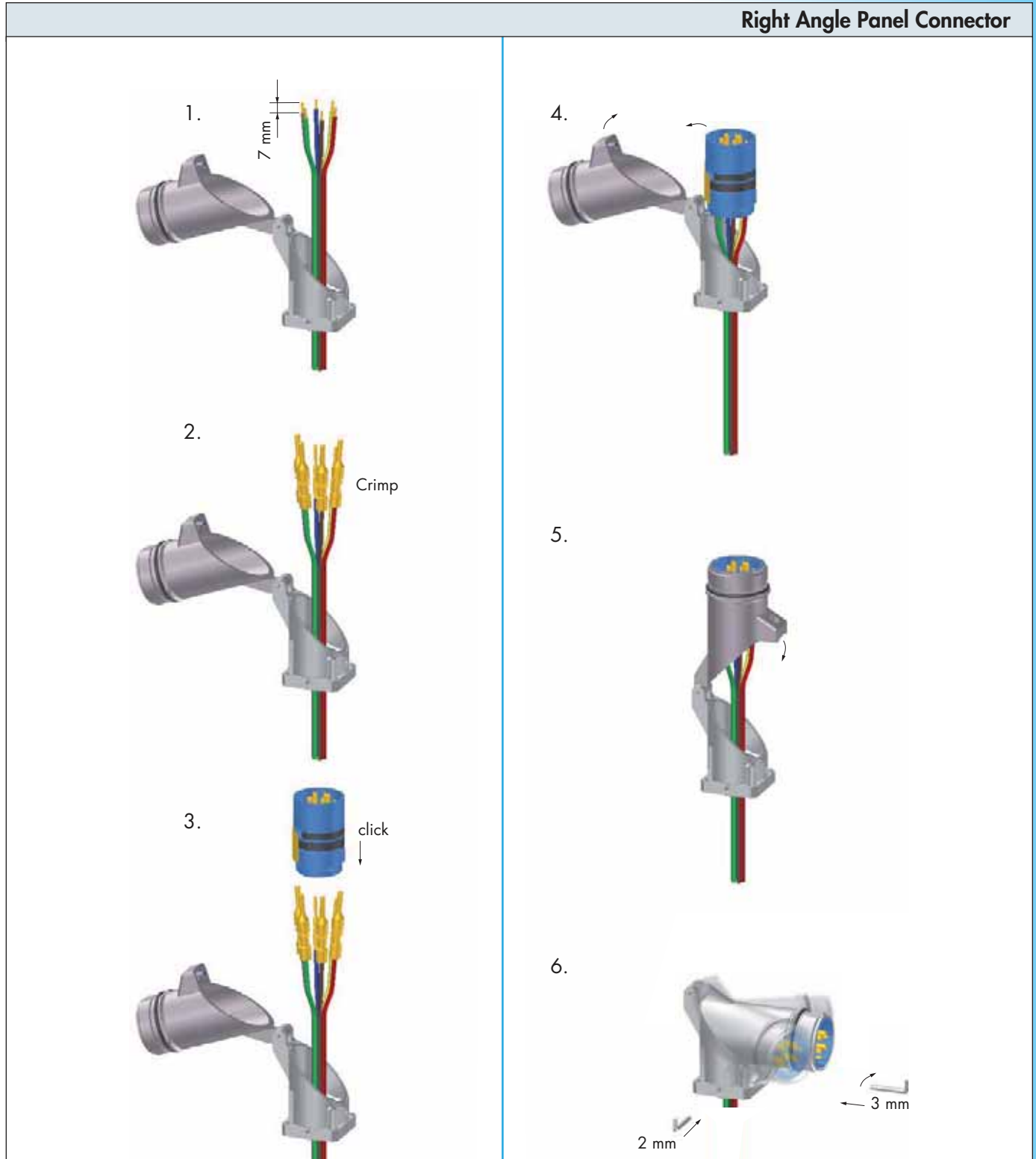

Crimping, Assembly and Disassembly

Crimping, Assembly and Disassembly



Crimping

- Strip wire ends 7 mm (.28")
- Dial appropriate setting of crimp tool (page 144)
- Push crimp contact into opening of crimping tool
- Insert stripped wire into the funnel shaped end of the crimp contact
- Squeeze handles of crimping tool together connect contact to wire

Assembly

- Remove crimped assembly and pull on wire to test connection
- Push into desired position of insert
Note: It is recommended to assemble the large contacts first.



Disassembly of Contacts from Insert

A small screwdriver is needed to remove the contacts from the insert.

- Release the white ring by a screwdriver out of the insert
- Move the misplaced contacts out of the insert
- Enter the ring back into the insert
- Push the contacts back into insert



Shielding

- Assemble strain relief insert with insert
- Fold stranding of the shield back over the first O-Ring of the strain relief insert
- Cut back the overextending braid

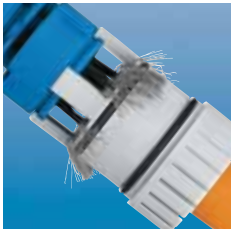

 The stranding of the shield is not allowed to touch the second O-Ring. Otherwise the assembly may not be proof.

TWILOCK



Product Overview

Housings	page 152

Inserts	page 22, 74, 114

Accessories	page 29, 82, 116
--------------------	-------------------------

TWILOCK Connectors

Mechanical Data	Materials and Technical Data
Housing	Copper-Zinc alloy Die Casting
Housing surface	Nickel plated, other surface upon request
Inserts (for contacts)	Thermoplastic Polyamid PA 6 (Nylon 6/6), PBT Fire protection class V-0
Contacts	Brass Alloy
Contact surface at point of contact	Nickel and gold plated (0,25 µm Au)
Minimum mating cycles	> 300
Seals / O-Rings	Buna-N standard optional Viton® (Viton is a registered trademark of DuPont)
Temperature range	-40° C – 125° C (-40 °F – 257 °F)
Type of contacts M 16	Crimp, dip-solder (PCB)
Type of contacts signal M 23	Crimp, solder, dip-solder (PCB)
Type of contacts power M 23, M 40	Crimp
Protection	IP 67 / IP 69K per EN 60 529 (connected), NEMA 4x

Additional Information

Electrical data see standard program

Connectors M 16	page 17
Signal Connectors M 23	page 65
Power Connectors M 23	page 107

Inserts and contacts see standard program

Connectors M 16	page 22
Signal Connectors M 23	page 74
Power Connectors M 23	page 114



We do not recommend disconnecting or connecting HUMMEL Connectors under load.

Characteristics

HUMMEL TWILOCK Connectors guarantee:

- Quick connecting cycle
- High protection rate
- Easy connection / disconnection even under tight space conditions

Circular Connectors TWILOCK M 16

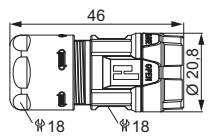
Straight Connector, Female Thread		Cable-Ø	Part Number
		3 – 6 mm (.12 – .24").....7.816.300.000	
		5 – 9 mm (.20 – .35").....7.816.400.000	
		8 – 11 mm (.31 – .43").....7.816.500.000	
Contacts and inserts page 22 • Assembly instructions page 34 / 35			

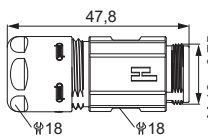
Straight Connector, Male Thread		Cable-Ø	Part Number
		3 – 6 mm (.12 – .24").....7.820.300.000	
		5 – 9 mm (.20 – .35").....7.820.400.000	
		8 – 11 mm (.31 – .43").....7.820.500.000	
Contacts and inserts page 22 • Assembly instructions page 34 / 35			

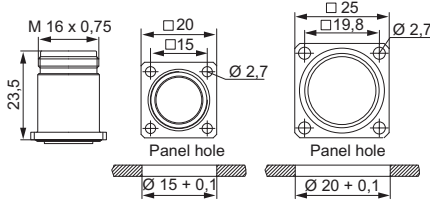
Panel Connector, Male Thread, Front Mounting		Type	Part Number
		4 x holes Ø 2,7 mm (.11") ..7.840.000.000 Flange 20 x 20 mm	
		4 x holes Ø 2,7 mm (.11") ..7.840.100.000 Flange 25 x 25 mm	
Contacts and inserts page 22 • Assembly instructions page 38			

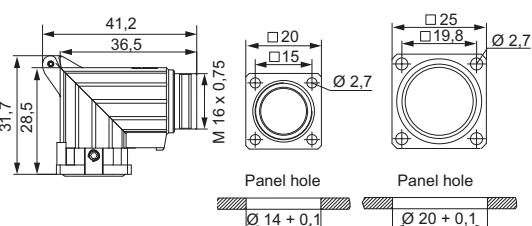
Right Angle Panel Connector, Male Thread, rotating		Type	Part Number
		300° rotating, locking screw at flange 4 x holes Ø 2,7 mm (.11") ..7.843.000.000 Flange 20 x 20 mm	
		4 x holes Ø 2,7 mm.....7.843.100.000 Flange 25 x 25 mm	
Contacts and inserts page 22 • Assembly instructions page 39			

Signal Connectors TWILOCK M23

Cable-Ø	Part Number	Straight Connector, Female Thread
3 – 7 mm (.12 – .28")	7.166.400.000	
7 – 12 mm (.24 – .47")	7.166.500.000	
11 – 17 mm (.43 – .67")	7.166.600.000	

Contacts and inserts page 74 • Assembly instructions page 88



Cable-Ø	Part Number	Straight Connector, Male Thread
3 – 7 mm (.12 – .28")	7.206.400.000	
7 – 12 mm (.24 – .47")	7.206.500.000	
11 – 17 mm (.43 – .67")	7.206.600.000	

Contacts and inserts page 74 • Assembly instructions page 88



Type	Part Number	Panel Connector, Male Thread, Front Mounting
With anti-vibration O-Ring		
4 holes Ø 3,2 mm (.13")	7.410.000.000	
4 threads M3	7.412.000.000	
4 holes Ø 2,7 mm (.11")	7.414.000.000	
4 threads M2,5	7.416.000.000	
Optional: Flat gasket		

Contacts and inserts page 74 • Assembly instructions page 91 / 92





Type	Part Number	Right Angle Panel Connector, Male Thread, rotating
300° rotating, 1,5 mm locking screw at flange		
4 x holes Ø 2,7 mm (.11")	7.433.000.000	
Flange 25 x 25 mm		
4 x holes Ø 3,2 mm	7.433.100.000	
Flange 28 x 28 mm		

Contacts and inserts page 74 • Assembly instructions page 93

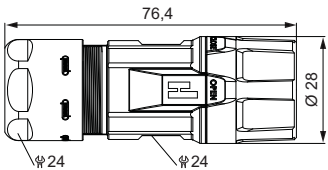

Power Connectors TWILOCK M23

Straight Connector, Female Thread		Cable-Ø	Part Number
		7 – 12 mm (.24 – .47").....7.556.500.000	
		11 – 17 mm (.43 – .67").....7.556.600.000	
		Contacts and inserts page 114 • Assembly instructions page 122	

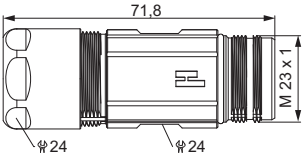
Straight Connector, Male Thread		Cable-Ø	Part Number
		7 – 12 mm (.24 – .47").....7.560.500.000	
		11 – 17 mm (.43 – .67").....7.560.600.000	
		Contacts and inserts page 114 • Assembly instructions page 122	

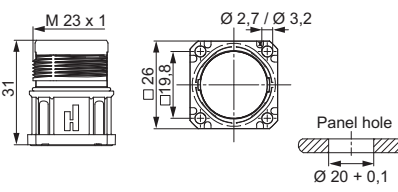
Panel Connector, Male Thread, Front Mounting		Type	Part Number
		4 holes Ø 3,2 mm (.13").....7.601.000.000	
		4 holes Ø 2,7 mm (.11").....7.605.000.000	
		Optional: Flat gasket	
		Contacts and inserts page 114 • Assembly instructions page 125	

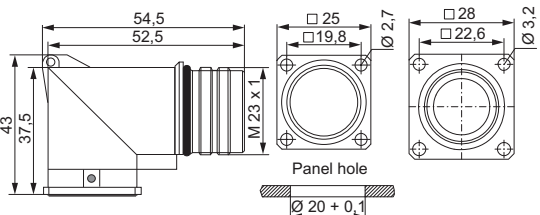
Right Angle Panel Connector, Male Thread, rotating		Type	Part Number
		300° rotating, locking screw at flange	
		4 x holes Ø 2,7 mm (.11") ..7.638.000.000 Flange 25 x 25 mm	
		4 x holes Ø 3,2 mm (.13") ..7.638.100.000 Flange 28 x 28 mm	
		Contacts and inserts page 114 • Assembly instructions page 127	

Push-Pull Technology Size M 40



Product Overview

Housings	page 158

Inserts	page 132

Accessories	page 138

Push-Pull Connectors

Mechanical Data	Materials and Technical Data
Housing	Copper-Zinc alloy Die Casting
Housing surface	Nickel plated, other surface upon request
Inserts (for contacts)	Thermoplastic Polyamid PA 6 (Nylon 6/6), PBT Fire protection class V-0
Contacts	Brass Alloy
Contact surface at point of contact	Nickel and gold plated (0,25 µm Au)
Minimum mating cycles	> 250
Seals / O-Rings	Buna-N standard optional Viton® (Viton is a registered trademark of DuPont)
Temperature range	-40° C – 125° C (-40 °F – 257 °F)
Type of contacts power M40	Crimp
Protection	IP 67 / IP 69 K per EN 60 529 (connected), NEMA 4x

Additional Information

Electrical data see standard program

Power Connectors Size 1,5

page 131

Inserts and contacts see standard program

Power Connectors Size 1,5

page 132



We do not recommend disconnecting or connecting HUMMEL Connectors under load.

Characteristics

HUMMEL Push-Pull Connectors guarantee:

- Quick connecting cycle
- EMC compatible connection due to radially locked metal ring
- High protection rate
- Easy connection / disconnection even under tight space conditions
- Best reliability with optional safety ring



Standard delivery of M40 (size 1.5) Power Connector include Contact Insert

Power Connectors Size 1,5 / Push-Pull

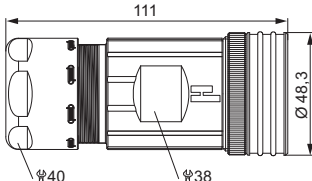
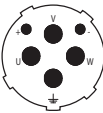
Straight Connector, Female Thread		Cable-Ø	Part Number
			2 + 3 + PE, insert for sockets 13 – 18 mm (.52 – .71").....7.715.623.000 17 – 24 mm (.67 – .95").....7.715.723.000 21 – 28 mm (.83 – 1.10")...7.715.823.000
			Optional: Safety ring Contacts page 136 • Assembly instructions page 145

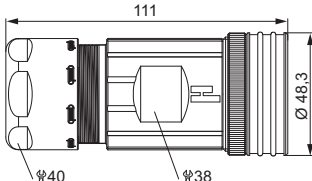
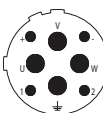
Straight Connector, Female Thread		Cable-Ø	Part Number
			4 + 3 + PE, insert for sockets 13 – 18 mm (.52 – .71").....7.715.643.000 17 – 24 mm (.67 – .95").....7.715.743.000 21 – 28 mm (.83 – 1.10")...7.715.843.000
			Optional: Safety ring Contacts page 136 • Assembly instructions page 145

Power Connectors Size 1,5 / Push-Pull

Cable-Ø	Part Number	Straight Connector, Male Thread		
2+3+PE, insert for pins 13 – 18 mm (.52 – .71").....7.725.623.000 17 – 24 mm (.67 – .95").....7.725.723.000 21 – 28 mm (.83 – 1.10")...7.725.823.000				
Contacts page 136 • Assembly instructions page 145				

Cable-Ø	Part Number	Straight Connector, Male Thread		
4+3+PE, insert for pins 13 – 18 mm (.52 – .71").....7.725.643.000 17 – 24 mm (.67 – .95").....7.725.743.000 21 – 28 mm (.83 – 1.10")...7.725.843.000				
Contacts page 136 • Assembly instructions page 145				

Power Connectors Size 1,5 / Push-Pull

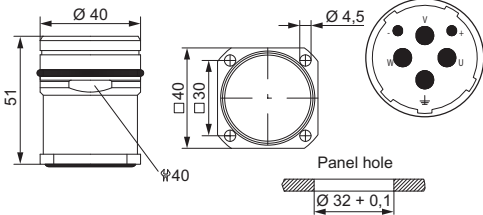
Panel Connector	Type	Part Number
	2 + 3 + PE, insert for pins 4 holes $\varnothing 4,5 \text{ mm}$ (.18")7.740.523.000	
		
Contacts page 136 • Assembly instructions page 146		

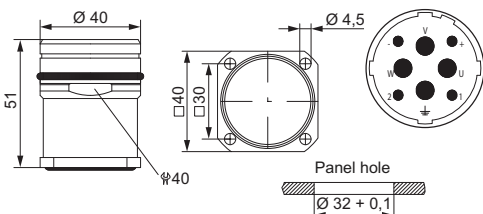
Panel Connector	Type	Part Number
	4 + 3 + PE, insert for pins 4 holes $\varnothing 4,5 \text{ mm}$ (.18")7.740.543.000	
		
Contacts page 136 • Assembly instructions page 146		

Stainless Steel Connectors (INOX)



Product Overview

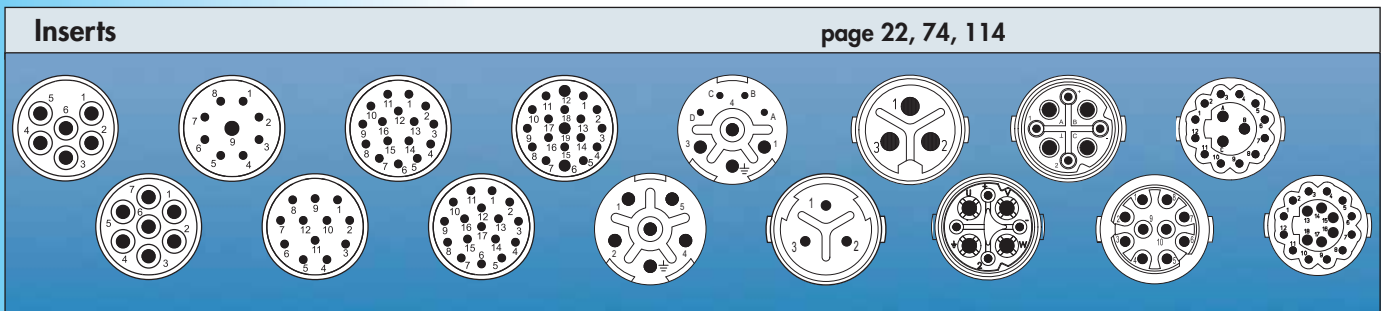

Connectors Stainless Steel (INOX)

Mechanical Data	Materials and Technical Data	
Housing	Stainless Steel V4A	1.4404 (AISI 316 L)
Housing surface	Clear	
Inserts (for contacts)	Thermoplastic Polyamid PA 6 (Nylon 6/6), PBT	Fire protection class V-0
Contacts	Brass Alloy	
Contact surface at point of contact	Nickel and gold plated (0,25 µm Au)	
Minimum mating cycles	> 1000	
Seals / O-Rings	Viton (FPM), alternativ EPDM	
Temperature range	-40° C – 125° C	
Type of contacts signal M23	Crimp, solder, dip-solder (PCB)	
Type of contacts power M23	Crimp	
Type of contacts M 16	Crimp, dip-solder (PCB)	
Protection	IP 67 / IP 69 K per EN 60 529 (connected), NEMA 4x	

Additional Information

Electrical data see standard program

Connectors M 16

Signal Connectors M23

Power Connectors M23

page 17

page 65

page 107

Inserts and contacts see standard program

Connectors M 16

Signal Connectors M23

Power Connectors M23

page 22

page 74

page 114





We do not recommend disconnecting or connecting HUMMEL Connectors under load.

Typical Applications



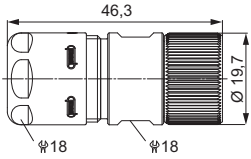

Signal Connectors M 16 / Stainless Steel (INOX)

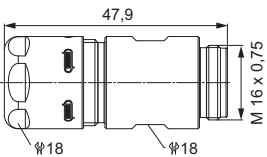
Straight Connector, Female Thread		Cable-Ø	Part Number
		3 – 6 mm (.12" – .24")	7.814.300.000
		5 – 9 mm (.20" – .35")	7.814.400.000
		8 – 11 mm (.31" – .43")	7.814.500.000
		Contacts and inserts page 22	

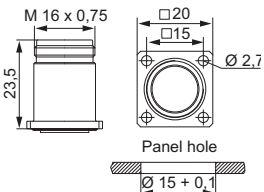
Straight Connector, Male Thread		Cable-Ø	Part Number
		3 – 6 mm (.12" – .24")	7.824.300.000
		5 – 9 mm (.20" – .35")	7.824.400.000
		8 – 11 mm (.31" – .43")	7.824.500.000
		Contacts and inserts page 22	

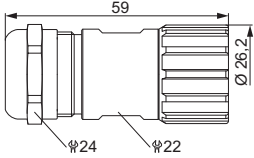

Panel Connector, Male Thread		Type	Part Number
		4 x holes Ø 2,7 mm (.11") ..	7.840.400.000
		Flange 20 x 20 mm	
		Contacts and inserts page 22 • Assembly instructions page 38	

Signal Connectors M 23 / Stainless Steel (INOX)

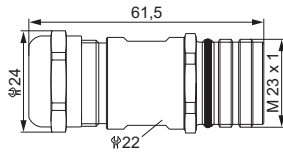

Cable-Ø	Part Number	Part Number EMC	Panel Connector, Male Thread
3 – 7 mm (.12 – .28")	7.140.300.000	7.141.300.000	 
5 – 10 mm (.20 – .39")	7.140.400.000	7.141.400.000	
7 – 12 mm (.24 – .47")	7.140.500.000	7.141.500.000	
10 – 14 mm (.39 – .55")	7.140.600.000	7.141.600.000	

Contacts and inserts page 74 • Assembly instructions page 168

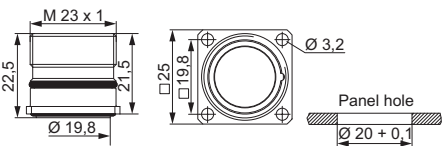

Assembly tool 7.010.900.127 is required

Cable-Ø	Part Number	Part Number EMC	Right Angle Panel Connector, Male Thread
3 – 7 mm (.12 – .28")	7.240.300.000	7.241.300.000	 
5 – 10 mm (.20 – .39")	7.240.400.000	7.241.400.000	
7 – 12 mm (.24 – .47")	7.240.500.000	7.241.500.000	
10 – 14 mm (.39 – .55")	7.240.600.000	7.241.600.000	

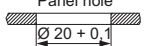
Contacts and Inserts page 74

Type	Part Number	Panel Connector, Male Thread
With anti-vibration O-Ring 4 holes Ø 3,2 mm (.13")7.410.400.000		
		

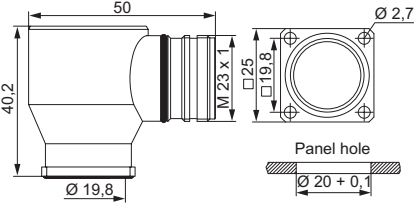
Contacts and inserts page 74 • Assembly instructions page 91 / 92

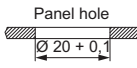
Type	Part Number	Right Angle Panel Connector, Male Thread
4 holes Ø 2,7 mm (.11")7.430.400.000		
		

Contacts and Inserts page 74

Power Connectors M 23 / Stainless Steel (INOX)

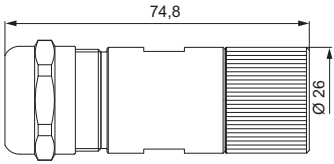
Straight Connector, Female Thread		Cable-Ø	Part Number
		7 – 12 mm (.24 – .47").....7.554.500.000	
		11 – 17 mm (.43 – .67").....7.554.600.000	
		Contacts and inserts page 114 • Assembly instructions page 122	

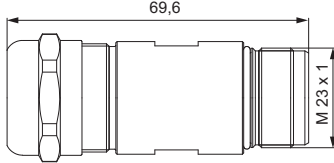
Straight Connector, Male Thread		Cable-Ø	Part Number
		7 – 12 mm (.24 – .47").....7.564.500.000	
		11 – 17 mm (.43 – .67").....7.564.600.000	
		Contacts and inserts page 114 • Assembly instructions page 122	

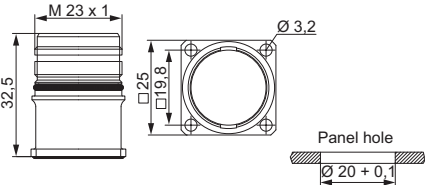
Panel Connector, Male Thread		Type	Part Number
		For front mounting	
		4 holes Ø 3,2 mm (.13").....7.601.400.000	
		Optional: Flat gasket	
		Contacts and inserts page 114 • Assembly instructions page 123	

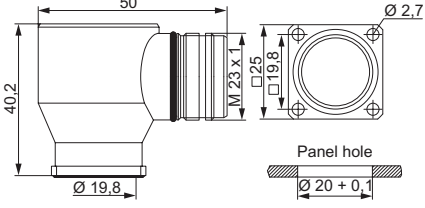
Right Angle Panel Connector, Male Thread		Type	Part Number
		4 holes Ø 2,7 mm (.11").....7.630.400.000	
		Contacts and Inserts page 114	

Stainless Steel Connectors (INOX) / Accessories

Type	Part Number	Accessories
Assembly tool	7.010.900.127	
Plastic protective cap for connectors M 16 with male thread for connectors M 16 with female thread for connectors M 23 with male thread for connectors M 23 with female thread	7.000.980.161 7.000.980.162 7.000.900.101 7.000.900.102	
Stainless steel protective cap for connectors with female thread..... Stainless steel protective cap with rope for connectors with female threadLength 100 mm	7.010.904.103 7.010.9S4.103	
Stainless steel protective cap for connectors with male thread Stainless steel protective cap with rope for connectors with male threadLength 100 mm	7.010.904.102 7.010.9S4.102	
Crimp tool for manual crimping of machined crimp contacts for signal connectors	7.000.900.901	
Operating instructions on page 85		
Crimp tool for manual crimping of machined crimp contacts for signal connectors M 16 and M 23	7.000.900.904	
Operating instructions on page 31		

Stainless Steel Connectors (INOX) / Assembly Instructions

Straight Signal Connector, Female Thread

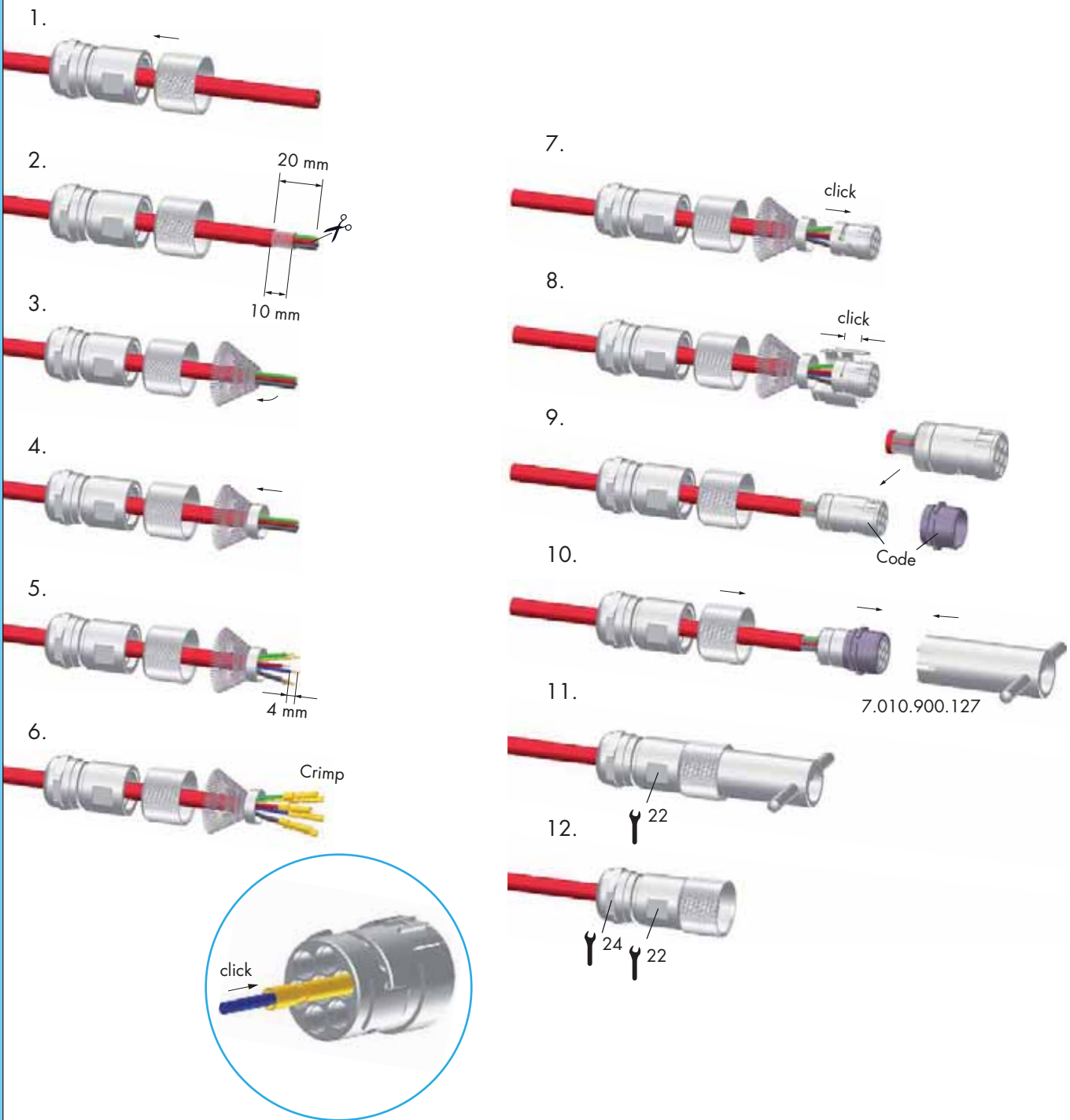

Moulded Cordsets



Product Overview

Moulded connector cordsets

page 172



Inserts

page 22, 74 and page 114

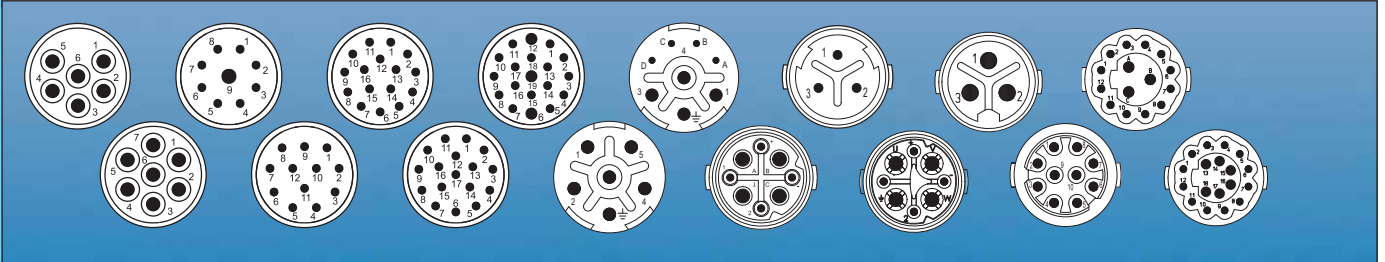

Accessories

page 29, 82 and page 116



Moulded Connector Cordsets

Mechanical Data	Materials and Technical Data
Housing	Copper-Zinc alloy Die Casting
Moulded strain relief	Polyurethan PUR
Housing surface	Nickel plated brass, black strain relief
Inserts (for contacts)	Thermoplastic Polyamid PA 6 (Nylon 6/6), PBT Fire protection class V-0
Contacts	Brass Alloy
Contact surface at point of contact	Nickel and gold plated (0,25 µm Au)
Minimum mating cycles	> 1000
Seals / O-Rings	Buna-N standard optional Viton® (Viton is a registered trademark of DuPont)
Temperature range	-40° C – 125° C (-40° F – 257° F)
Type of contacts	Crimp
Protection	IP 67 / IP 69K per EN 60 529 (connected), NEMA 4x
Cable style	Cable specifications available upon request
Labelling	HUMMEL logo as standard, other options available upon request

Additional Information

Electrical data see standard program

Connectors M 16

Signal Connectors M23

Power Connectors M23

page 17

page 65

page 107

Inserts and contacts see standard program

Connectors M 16

Signal Connectors M23

Power Connectors M23

page 22

page 74

page 114



We do not recommend disconnecting or connecting HUMMEL Connectors under load.

Other versions



Moulded connector cordsets are also available as Stainless-Steel (Inox)-Versions.

Moulded Connector Cordsets M 16

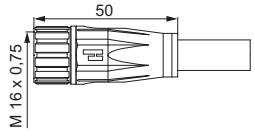
Straight Connector, Female Thread		Type	Inserts
 		Standard / EMC	Pins or sockets

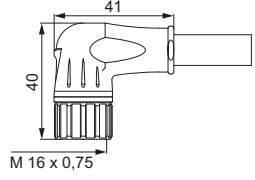
Right Angle Connector, Female Thread		Type	Inserts
 		Standard / EMC	Pins or sockets

Moulded Connector Cordsets M 23

Type	Inserts	Straight Connector, Female Thread	
Standard / EMC	Pins or sockets		

Type	Inserts	Straight Connector, Male Thread	
Standard / EMC	Pins or sockets		

Type	Inserts	Right Angle Connector, Female Thread	
Standard / EMC	Pins or sockets		

Type	Inserts	Right Angle Connector, Male Thread	
Standard / EMC	Pins or sockets		

Moulded Connector Cordsets M23

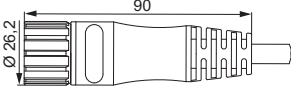
Straight Connector, Female Thread	Type	Inserts
 	Standard / EMC	Pins or sockets

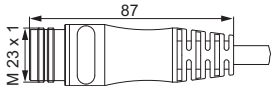
Straight Connector, Male Thread	Type	Inserts
 	Standard / EMC	Pins or sockets

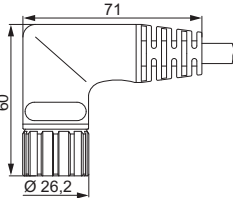
Right Angle Connector, Female Thread	Type	Inserts
 	Standard / EMC	Pins or sockets

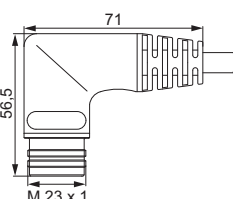
Right Angle Connector, Male Thread	Type	Inserts
 	Standard / EMC	Pins or sockets

Moulded Connector Cordsets / Accessories

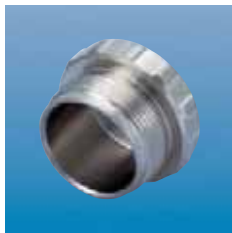
Type	Part Number	Accessories
Plastic protective cap for connectors M 16 with male thread.....	7.000.980.161	
for connectors M 16 with female thread.....	7.000.980.162	
for connectors M 23 with male thread.....	7.000.900.101	
for connectors M 23 with female thread.....	7.000.900.102	
Brass protective cap for connectors M 16 with female thread.....	7.010.900.163	
for connectors M 23 with female thread.....	7.010.900.103	
for connectors M 23 with female thread.....	7.010.900.183	
Brass protective cap for connectors M 16 with male thread.....	7.010.900.162	
for connectors M 23 with male thread.....	7.010.900.102	
Brass protective cap with chain für Steckverbinder M 16 with female thread.....Length 70 mm.....	7.010.9S0.705	
for connectors M 23 with female thread.....Length 70 mm.....	7.010.9S0.703	
.....Length 100 mm.....	7.010.9S1.003	
for connectors M 23 with female thread.....Length 70 mm.....	7.010.9S0.783	
.....Length 100 mm.....	7.010.9S1.083	
Brass protective cap with chain for connectors M 16 with male thread.....Length 70 mm.....	7.010.9S0.704	
for connectors M 23 with male thread.....Length 70 mm.....	7.010.9S0.702	
.....Length 100 mm.....	7.010.9S1.002	

IP 67 – liquid tight when disconnected



Using a rubber diaphragm makes this connector liquid tight either connected or disconnected (NEMA 4 = IP 67).

Bulkhead Connector



Bulkhead connectors accept plugs on both sides. They are rugged, liquid tight and available in all number of poles.

Simple EMI / RFI shielding

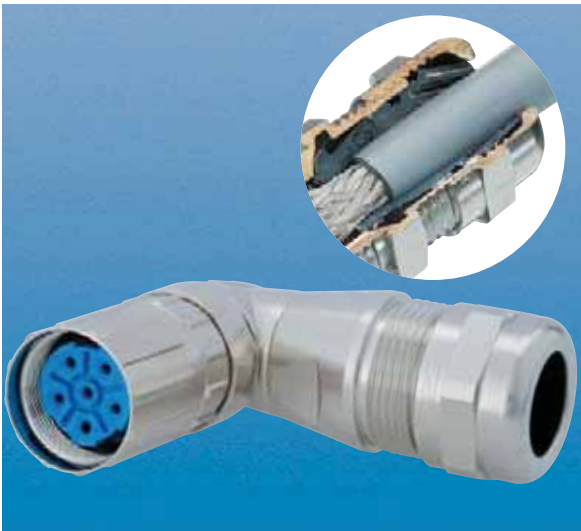

An integrated metalized EMI clamping insert grounds to the braid significantly simplifying the assembly of the elbow connector.

MULTI Seal Connector



A large selection of standard MULTI seal inserts allow strain relief of several individual conductors on one single connector.

Flexible Cable Protection



In addition to the integrated strain relief, the flex nut adds kink protection to a cable - available for all connector sizes.

Adaptor flange



To secure loose connections, an adaptor flange can be attached to a straight connector.

12-point hex and knurled nut



This special nut makes connection simple by either tightening the connector manually (knurled nut) or with a wrench (12-point hex).

Conduit Attachment



Flexible corrugated conduit can be attached to a connector with an adapter offering strain relief and cable protection as well.

Connector with specific pull-out resistance



After reaching a certain pull-out force the connection releases preventing damage to the device (apparatus).

Bulkhead Fitting



This fitting with oversized flange is commonly used in the ship building industry where Signal Connections have to be maintained under extreme conditions.

Captive Protective Cap



The metal protective cap is secured to a cable by a safety ring and stays attached in open connections.

ANACONDA Conduit Adapter



HUMMEL offers custom adapters for ANACONDA conduit systems in hazardous locations.

Distribution-box



Distribution-boxes are known as important components for applications in automation. Robust and fully wired they are done according to customers specification.

Coloured Overmould



Completing a design or showing technical functions, overmould could be made in different colours too (e.g. DESINA green RAL 6018).

High temperature applications



For high temperature applications HUMMEL offers connectors with special inserts able to stand temperatures up to 160 °C (320 °F).

Hybrid Connector for Compressed Air



To place lines for compressed air and electrical signals in one single connection, a hybrid connector M23 combines different types of contacts in one insert.

Derating

Derating M 16

Straight connectors male + female, 10 pole,
wires 10 x AWG 18

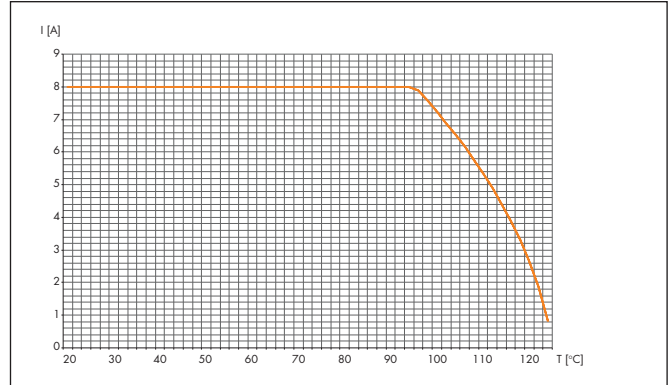

Derating M 16 TWINTUS

TWINTUS and straight connector female M 16
4+3+PE, wires AWG 14 (Power)
10pole, wires AWG 26

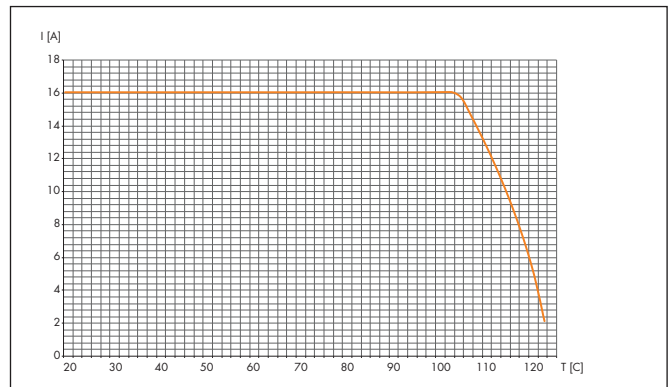

Derating M 23 Signal

Straight Connectors male + female,
wires 12 x AWG 17

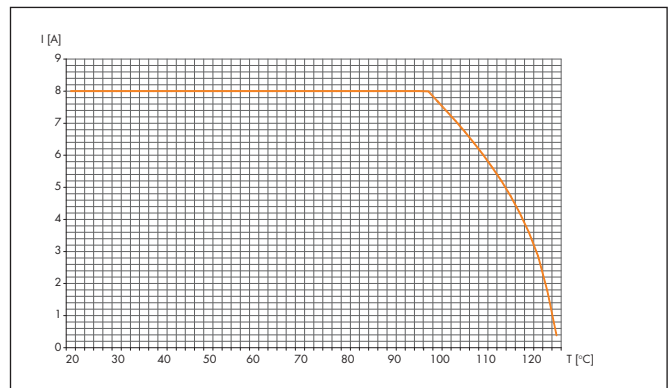

Derating M 23 Power

Straight connectors male + female M 23, 5 + PE,
wires 5 x AWG 12

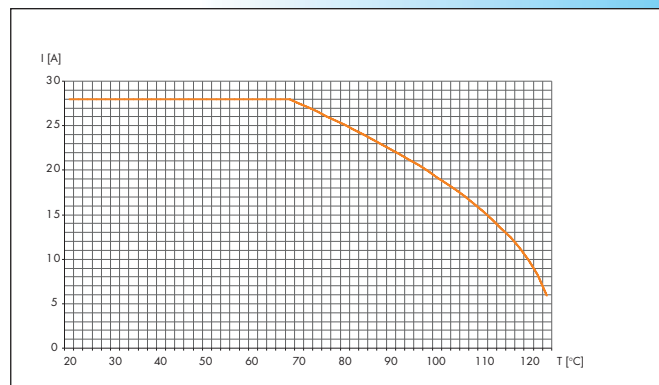

Derating M 40 (Size 1,5)

Straight connectors male + female,
wires 3 x AWG 6

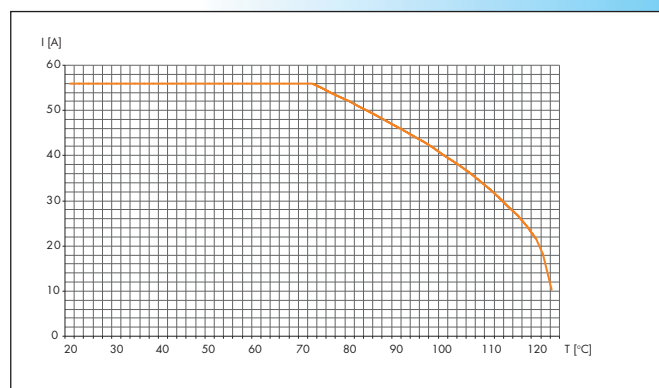

Page Finder

Part Number	Page	Part Number	Page	Part Number	Page	Part Number	Page
7.000.848.101	30	7.010.900.129	139	7.084.951	114	7.569	108
7.000.848.102	30	7.010.900.135	30	7.106	66	7.575	155
7.000.900.101		7.010.900.139	52	7.108	44	7.576	109
.51, 59, 82, 116, 165		7.010.900.14	53	7.110	98	7.579	109
7.000.900.102		7.010.900.162	29	7.105	73	7.580	109
.51, 59, 82, 116, 165		7.010.900.163	29	7.140	162	7.589	109
7.000.900.151	138	7.000.980.167	101	7.141	162	7.601	110
7.000.900.152	138	7.000.980.168	101	7.156	153	7.601.4	164
7.000.900.901		7.010.900.170	101	7.206	66	7.605	110
101, 117, 165		7.010.900.183	51	7.208	44	7.621	111
7.000.900.902	139	7.010.900.200	30	7.210	98	7.623	111
7.000.900.903	139	7.010.900.201	30	7.240	162	7.626	111
7.000.900.904	30, 83	7.010.900.202	30	7.241	162	7.630.4	164
7.000.900.906	52	7.010.900.203	30	7.300	67	7.635	112
7.000.900.907	52	7.010.900.204		7.301	67	7.636	112
7.000.980.16	29	.51, 60, 83, 117		7.304	153	7.637	112
7.000.980.167	101	7.010.900.205		7.305	153	7.638	112
7.000.980.168	101	.51, 60, 83, 117		7.306	67	7.638.1	112
7.000.9DM.C03	83	7.010.900.206		7.308	44	7.641	110
7.000.9DM.C04	83	.51, 60, 83, 117		7.350	67	7.645	110
7.000.9DM.C06	117	7.010.900.207		7.400	68	7.651	111
7.000.9DM.C07	117	.51, 60, 83, 117		7.402	68	7.653	113
7.001.903	22	7.010.900.208		7.404	68	7.661	113
7.001.906	74	.51, 60, 83, 117		7.406	68	7.681	113
7.001.907	74	7.010.900.209		7.408	44	7.683	113
7.001.908	23	.51, 60, 83, 117		7.410.0	68	7.710	132
7.001.910	24	7.010.900.214	139	7.410.4	163	7.715	156
7.001.912	76	7.010.900.215	139	7.410.7	98	7.720	132
7.001.916	77	7.010.900.216	139	7.412	68	7.725	157
7.001.917	77	7.010.900.217	139	7.414	68	7.740.0	133
7.001.919	78	7.010.900.129	139	7.416	68	7.740.5	158
7.001.920	46	7.010.901.001	26, 80	7.420	69	7.742	134
7.001.926	99	7.010.901.002	26, 46, 80	7.421	69	7.743	134
7.001.928	99	7.010.901.012	27, 46, 80	7.422	69	7.744	133
7.001.943	23	7.010.901.021	80	7.423	69	7.810	18
7.001.981	75	7.010.901.022	46, 80	7.425	69	7.813	152
7.001.983	22	7.010.901.031	80	7.430.4	163	7.820	18
7.001.985	24	7.010.901.5	80, 81	7.431	70	7.823	152
7.001.988	25	7.010.902.0	81	7.432	70	7.830	18
7.002.912	76	7.010.904.102	165	7.433	70	7.831	18
7.002.917	78	7.010.904.103	165	7.433.1	70	7.840	19
7.002.981	75	7.010.94	115	7.435	70	7.840.3	152
7.003.903	22	7.010.950.102	154	7.440.0	68	7.842	20
7.003.906	74	7.010.955.102	154	7.440.5	154	7.843	20
7.003.907	74	7.010.971	100	7.444	68	7.845	20
7.003.908	23	7.010.980.6	46, 47	7.448.0	68	7.847	19
7.003.910	24	7.010.980.8	23, 26, 27	7.448.5	154	7.848	21
7.003.912	76	7.010.981	23, 27	7.449	68	7.850.0	20
7.003.916	77	7.010.982	28	7.450	71	7.850.3	152
7.003.917	77	7.010.950.702		7.452	71	7.852	19
7.003.919	78	.51, 59, 82, 116		7.454	71	7.810.4	56
7.003.920	46	7.010.950.703	82	7.456	71	7.820.4	56
7.003.926	99	7.010.950.704	29	7.458	71	7.840.0	56
7.003.943	23	7.010.950.705	29	7.459	71	7.841.0	56
7.003.981	75	7.010.950.707	101	7.460	71	7.842.0	57
7.003.983	22	7.010.950.708	101	7.462	71	7.850.0	57
7.003.985	24	7.010.950.783	51	7.464	71	7.843.0	57
7.003.988	25	7.010.951.002		7.466	71	7.845.0	57
7.004.912	76	.51, 59, 82, 116		7.468	45	7.852.4	58
7.004.917	78	7.010.951.003	82	7.476	66	7.847.4	58
7.004.981	75	7.010.951.083	51	7.486	66	7.701	73
7.010.900.101	82	7.010.954.102	165	7.490	72	7.702	73
7.010.900.102		7.010.954.103	165	7.491	72		
.51, 59, 82, 116		7.015.95	136, 137	7.492	72		
7.010.900.103	82	7.015.900.102	138	7.550	108		
7.010.900.110	101	7.015.900.103	138	7.554	164		
7.010.900.125	29	7.015.9S1.002	138	7.555	155		
7.010.900.127	165	7.015.9S1.003	138	7.559	108		
7.010.900.128		7.053.9	23	7.560	108		
.59, 83, 117		7.084.943	114	7.564	164		

Limited Liability

Products, design, colors and dimensions are subject to change without prior notice. We reserve the right to make technical improvements on all our products, currently ordered or for future orders. It is the users responsibility to verify all dimensions and technical data. HUMMEL AG will assume no liability regarding information provided to the user by published literature or inside technical staff, its distributors and outside sales personnel. Errors in the catalog can occur and shall not create any liability whatsoever for HUMMEL. All information provided by HUMMEL is without guarantee and must be verified by the user.

Created and printed by

Graphic & Layout: intermedia marketing gmbh, Mozartstraße 2, 79183 Waldkirch, Germany, Tel. +49 (0) 76 81 / 47 78 99-0, Fax +49 (0) 76 81 / 47 78 99-27, kontakt@intermedia-marketing.de
Printer: Druckerei Furtwängler GmbH, 79211 Denzlingen, Germany, Tel. +49 (0) 76 66 / 13 31. Printed on recycled paper in March 2012. English 2012

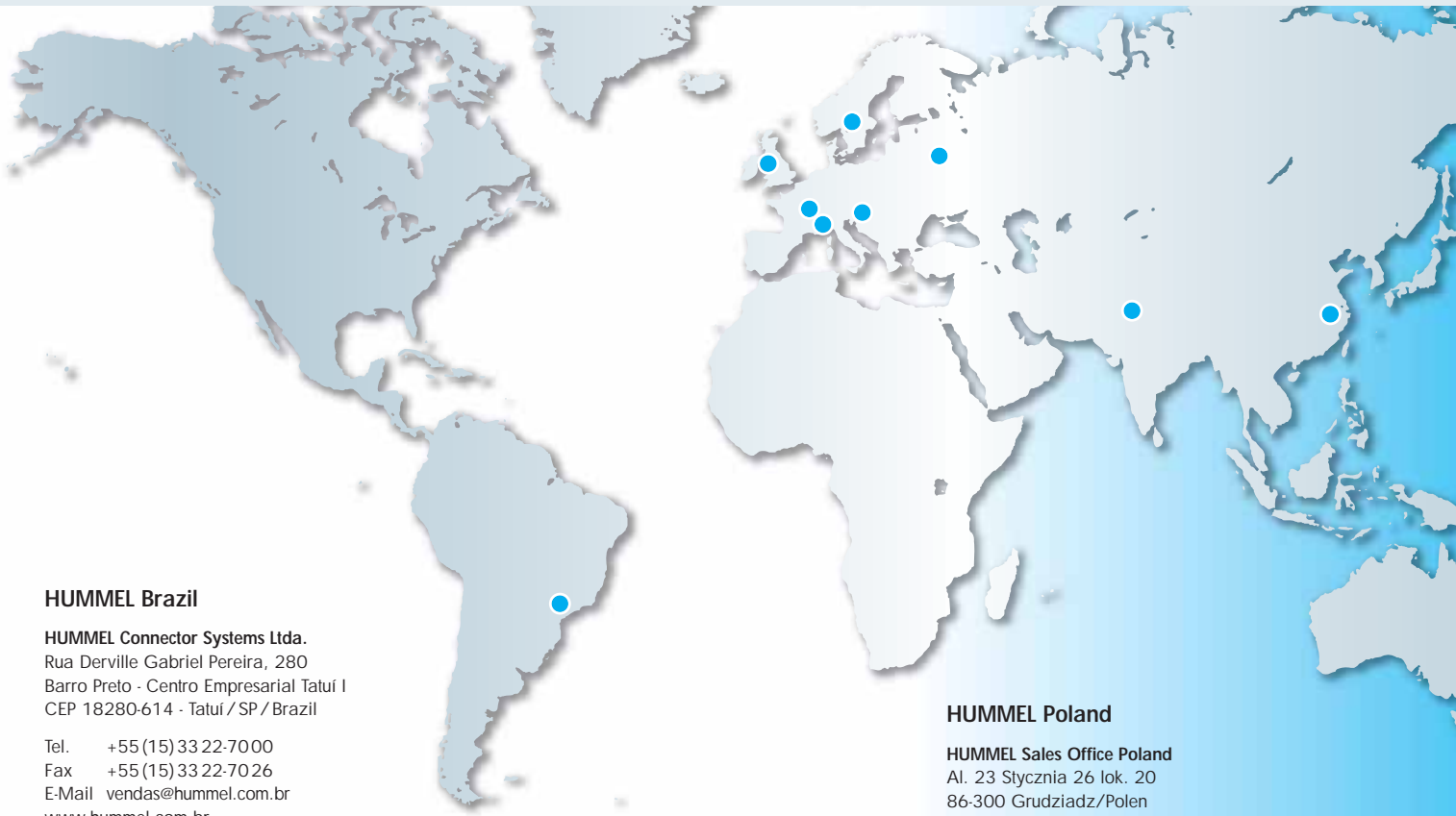

HUMMEL Brazil

HUMMEL Connector Systems Ltda.
Rua Derville Gabriel Pereira, 280
Barro Preto - Centro Empresarial Tatuí I
CEP 18280-614 - Tatuí / SP / Brazil

Tel. +55 (15) 33 22-7000
Fax +55 (15) 33 22-7026
E-Mail vendas@hummel.com.br
www.hummel.com.br

HUMMEL China

HUMMEL Connector Systems (Shanghai) Co., Ltd.
Room 1701 Central Plaza
No.227 Huang Pi (N) Road
200003 Shanghai / P.R. China

Tel. +86 / 21 63 75 85-51
Fax +86 / 21 63 75 85-53
E-Mail info.hcs.cn@hummel.com
www.hummel.com

HUMMEL France

HUMMEL s.a.r.l.
4, rue des fleurs
68190 Ungersheim / France

Tel. +33 (0) 3 89 / 55 37 20
Fax +33 (0) 3 89 / 53 80 27
E-Mail info.fr@hummel.com
www.hummel.com

HUMMEL UK

HUMMEL UK Limited
Office 3, Momentum House
Enterprise Way, Lowton St Marys,
Warrington, Cheshire, WA3 2BP
United Kingdom

Tel. +44 (0) 1942 / 60 56 95
Fax +44 (0) 1942 / 26 93 24
E-Mail s.kelly@hummel.com
www.hummel.com

HUMMEL India

HUMMEL Connector Systems Pvt. Ltd.
1211, Surya Kiran Building, 19,
Kasturba Gandhi Marg
110001 New Delhi/India

Tel. +91/11/ 430075-21/- 23
Fax +91/11/430075-22
E-Mail info.in@hummel.com
www.hummel.com

HUMMEL Italy

HUMMEL s.r.l.
Via Valdellatorre 182
10091 Alpignano (Torino) / Italy

Tel. +39 / (0) 11 / 9 68 26 38
Fax +39 / (0) 11 / 9 78 55 50
E-Mail info.it@hummel.com
www.hummel.com

HUMMEL Kazakhstan

HUMMEL Sales Office Kasachstan
Turksibskij rayon, Mikrorayon Zhuldyz-1,
dom 6, kvartira 19
050049 Almaty/Kasachstan

Tel. +7 701 7262004
E-Mail a.zholdybayev@hummel.com
www.hummel.com

HUMMEL Poland

HUMMEL Sales Office Poland
Al. 23 Stycznia 26 lok. 20
86-300 Grudziadz/Polen

Tel. +48 (0) 662382799
Fax +48 (0) 566430011
E-Mail g.piotrowski@hummel.com
www.hummel.com

HUMMEL Russia

OOO HUMMEL
Retschnikov 21, Strojenije 1
115142 Moskau / Russia

Tel. +7 / 499 / 782-40 75
Fax +7 / 499 / 6 14-67 40
E-Mail info@hummel-russia.ru
www.hummel-russia.ru

HUMMEL Scandinavia

HUMMEL Connector Systems AB
Första Magasinsgatan 5
80310 Gävle / Sweden

Tel. +46 / 73 800 1200
Fax +46 / 26 14 38 73
E-Mail info.se@hummel.com
www.hummel.com

HUMMEL Hungary

HUMMEL Ungarn Kft.
Ko'rosi út 49.
2360 Gyál / Hungary

Tel. +36 / 29 54 06 33
Fax +36 / 29 54 06 35
E-Mail info.hcs.hu@hummel.com
www.hummel.com

HUMMEL Divisions

Touch

Touchsensors - Touchpanels - Touchsystems



Electronic

Operator Panels - Frontsheets and Keyboards
Custom fabrication of Enclosures - Battery Chargers - Cable Assembly
Sensors - Controls - Systems Solutions - Temperature Controllers



Electro Technology

Industrial Enclosures - Cable Glands
Cable Protection - Circular Connectors



Heating Equipment

Valves and Fittings - Compression Fittings
Heat Pumps - Thermostatic Heads



Customized

Parts made of Metal and Nylon



www.hummel.com

HUMMEL AG

Division ET
Lise-Meitner-Straße 2
79211 Denzlingen
Germany

Tel. +49 (0)76 66 / 9 11 10-0
Fax +49 (0)76 66 / 9 11 10-20
E-Mail info.et@hummel.com

HUMMEL AG

Lise-Meitner-Straße 2
79211 Denzlingen
Germany
www.hummel.com

